

THIS DRAWING IS UNPUBLISHED. RELEASED FOR PUBLICATION NOV, 2006.
 © COPYRIGHT 2006 BY TYCO ELECTRONICS CORPORATION. ALL RIGHTS RESERVED.

LOC	DIST	REVISIONS					
E	B	P	LTR	DESCRIPTION	DATE	DWN	APVD
		A		FIRST ISSUE	16NOV06	JMS	FWK

- NOTES**
- 1 SINGLE PACK IN ACCORDANCE WITH AMP SPEC 107-3275
 - 2 100 TRAY PACK IN ACCORDANCE WITH AMP SPEC 107-3275
 - 3 NI PLATING
 - 4 TIN PLATING
5. **ELECTRICAL CHARACTERISTICS**
 FREQUENCY RANGE: DC - 2 GHz
 NOMINAL IMPEDANCE: 75 Ohm
 INSULATION RESISTANCE: N/A
 WORKING VOLTAGE: N/A
 DIELECTRIC WITHSTAND VOLTAGE: N/A
 CONTACT RESISTANCE: N/A
 CENTRE CONTACT: N/A
 OUTER CONTACT: N/A
 VSWR @ 3GHz: 1.35:1
 INSERTION LOSS dB @ x 1.5 GHz: N/A
6. **MECHANICAL CHARACTERISTICS**
 COUPLING NUT PROOF TORQUE: 3.4 Nm
 CABLE RETENTION FORCE: N/A
 DURABILITY: 50 Cycles Min
7. **ENVIRONMENTAL CHARACTERISTICS**
 OPERATING TEMPERATURE: -55 to +85 DegC
8. FOR TECHNICAL DATA REFER TO YOUR LOCAL TYCO ELECTRONICS SALES OFFICE
9. ALL DIMENSIONS ARE NOMINAL FOR REFERENCE ONLY UNLESS OTHERWISE STATED

DIE SET	E	D	C	B	A	CABLE GROUPS	PART NO.
9-1478243-0	8.30	9.30	8.30	7.00	5.70	CT125	5-1814826-7
9-1478243-0	8.30	9.30	8.30	7.00	5.70	CT125	5-1814826-6
9-1478242-0	6.50	7.50	6.70	5.60	4.60	CT100	5-1814826-5
9-1478242-0	6.50	7.50	6.70	5.60	4.60	CT100	5-1814826-4
9-1478243-0	8.60	9.60	8.70	6.80	4.85	RG6/U	5-1814826-3
9-1478243-0	8.60	9.60	8.70	6.80	4.85	RG6/U	5-1814826-2
9-1478242-0	6.50	7.50	6.80	4.90	3.90	RG59B/U, 62A/U, 140/U, 210/U, URM90, Belden 9291, 9291, KX6A, KX25, KX52, KX53	5-1814826-1
9-1478242-0	6.50	7.50	6.60	4.90	3.90	RG59B/U, 62A/U, 140/U, 210/U, URM90, Belden 9291, 9291, KX6A, KX25, KX52, KX53	5-1814826-0

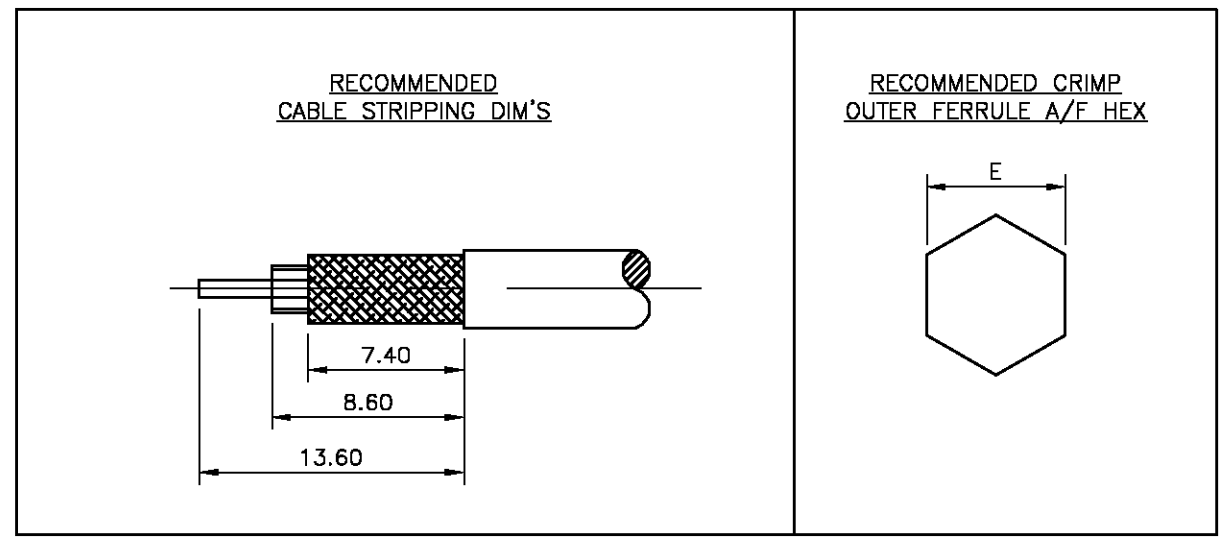
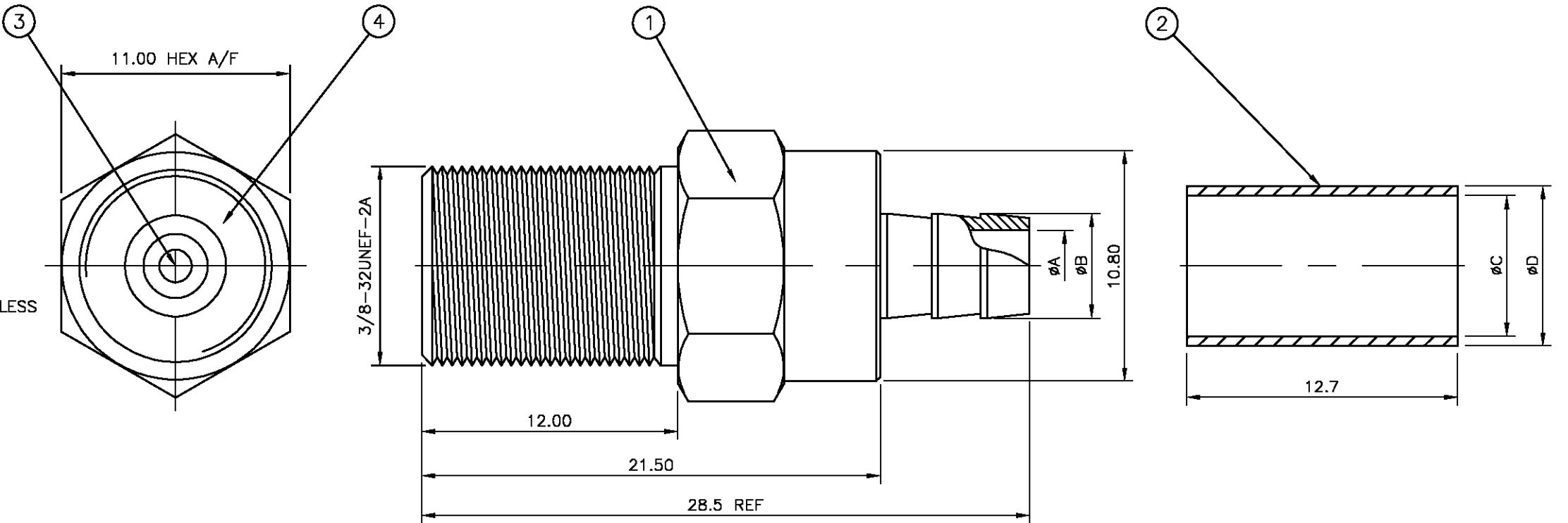

1	1	1	1	1	1	1	1	1	POLYPROPYLENE	INSULATOR	4
1	1	1	1	1	1	1	1	1	BRASS	CONTACT	3
1	1	1	1	1	1	1	1	1	ZINC ALLOY	FERRULE	2
1	1	1	1	1	1	1	1	1	BRASS	BODY	1
5	75	65	55	45	35	25	15	0	MATERIAL	DESCRIPTION	ITEM

THIS DRAWING IS A CONTROLLED DOCUMENT.

DWN: J.SANDWELL 16NOV06
 CHK: S.PARLOW 16NOV06
 APVD: F.WHEELER-KING 16NOV06

tyco Electronics Tyco Electronics Corporation
 Bideford, UK, EX39 4HE

NAME: F TYPE BLK JK R/M

SIZE: A3 CAGE CODE: 00779 DRAWING NO: C-1814826 RESTRICTED TO: -

WEIGHT: -

CUSTOMER DRAWING SCALE: NTS SHEET: 1 OF 1 REV: A