

## Atmel AVR® datasheet



### Contents

1. About this document
2. General information
3. Board overview
4. Getting Started
5. Block schematic and description

### Appendix

- A. Circuit diagram
- B. Compatible AVR® device
- c. Bus connections

# 1 About this document

This document concerns the Matrix Atmel AVR® Board code EB-194-00-1.

## ***Trademarks and Copyright***

PIC, PICmicro are registered trademarks of Arizona Microchip Inc.

E-blocks is a trademark of Matrix Multimedia Limited.

EB-194-00-1 and associates software and documentation are Copyright ©2004 Matrix Multimedia Limited.

## ***Other sources of information***

There are various other documents and sources that you may find useful:

### **Getting started with E-Blocks.pdf**

This describes the E-blocks system and how it can be used to develop complete systems for learning electronics and for PICmicro programming.

## ***Disclaimer***

The information in this document is correct at the time of going to press. Matrix Multimedia reserves the right to change specifications from time to time.

## ***Technical support***

If you have any problems operating this product then please refer to the troubleshooting section of this document first. You will find the latest software updates, FAQs and other information on our web site: [www.matrixmultimedia.co.uk](http://www.matrixmultimedia.co.uk). If you still have problems please email us at: [support@matrixmultimedia.co.uk](mailto:support@matrixmultimedia.co.uk). When emailing please state the operating system, the version of PPP you are using.

## 2 General information

### *Description*

This new AVR® microcontroller programmer connects to your PC via an in circuit programmer to provide you with one of the world's lowest cost and most flexible AVR® microcontroller programmers. The board is fully compatible with our entire range of E-blocks allowing the investigation into many interesting and exciting projects.

The Atmel AVR® Board allows serial programming of a large selection of 20 and 40 pin Atmel AVR® devices. This board uses Atmel's AVR® studio – a free and comprehensive downloadable AVR® program. The board can be programmed using Assembly and C. It provides 'clean' access to all I/O lines on the relevant Atmel AVR® devices.

Further information on E-blocks is available in a separate document entitled Introduction to E-blocks.doc.

### *Features*

- E-blocks compatible
- Low cost
- Used as a programmer and as a development board
- Programs a wide range of Atmel AVR® devices
- Full suite of programming software
- Xtal operation and internal RC operation
- 4 full I/O ports

### 3 Board overview

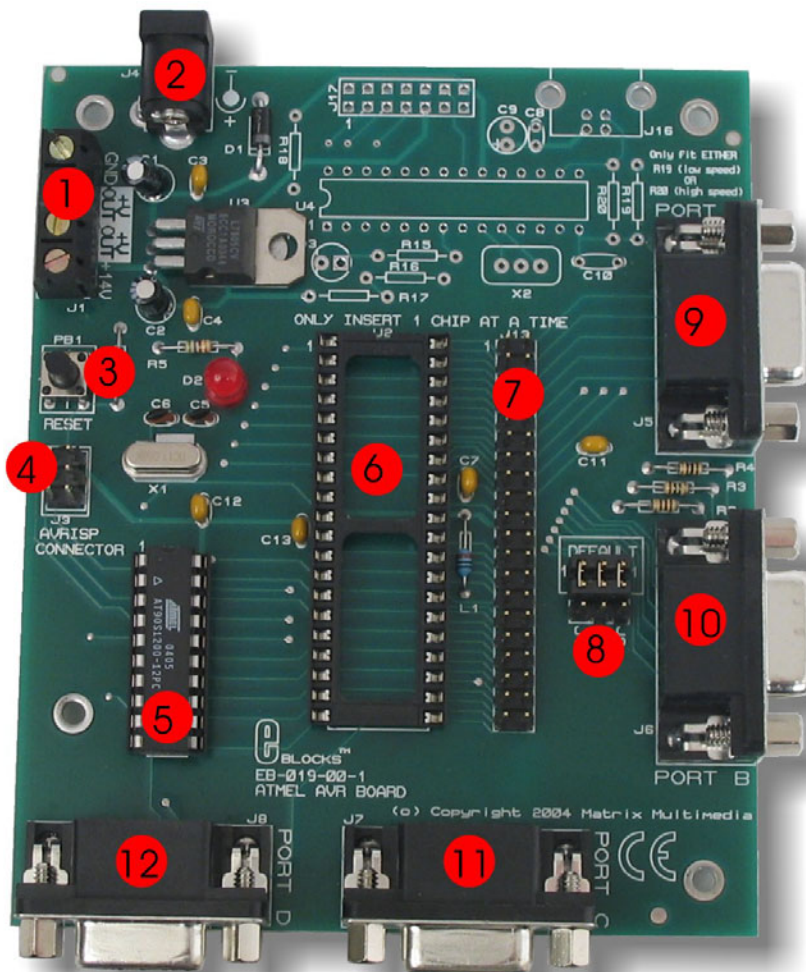

1. Screw Terminals
2. Power connector (positive outer – negative inner)
3. Reset switch
4. AVRISP programming connector
5. 20-way AVR® socket with AVR® device
6. 40-way AVR® socket
7. 40-way header mirroring AVR® pins
8. Default programming block
9. Port A I/O
10. Port B I/O
11. Port C I/O
12. Port D I/O

## 4 Getting Started

### 4.1 Installation instructions - Software

#### Installing AVR® Studio 4 from AVR® ISP CD

1. Insert Atmel AVR® CD into CD drive.
2. Click 'Start' in the pop-up screen. The AVR web page will now be running from the CD.
3. Click 'Software' on the left hand toolbar.
4. Next, click "AVR Studio 4:" This will show you all the features available using the AVR Studio software
5. Scroll down to the CD marked "Install AVR Studio4.xx Build (Press "Open" when prompted). By clicking on this – then pressing "Open" when prompted, will allow you to install the software
6. Follow the on-screen instructions.

For the most –up-to-date version of this software please visit the Atmel web page at:

[www.atmel.com](http://www.atmel.com)

#### Installing AVR® Studio 4 from Atmel's Web page

1. Click on the "Products" icon
2. Using the left hand toolbar, click on "Microcontrollers", then "AVR 8-bit RISC"
3. Again using the left hand toolbar click on "Tools & Software"
4. Scroll down to the CD marked "AVR Studio4.xx Buildxx. By clicking on this – then pressing "Open" when prompted, will allow you to install the software.
5. Follow the on-screen instructions.

For more help and guidance on installing AVR® Studio visit the Atmel Website at: [www.atmel.com](http://www.atmel.com)

### 4.3 Programming the AT90S1200

#### Testing the Atmel AVR® Board – 90S1200.hex

The following instructions explain the steps to test and use your Atmel AVR® Board. The instructions assume that AVR® Studio is installed and functional. It also assumes that the test program *90S1200.hex* has been downloaded. This test routine is a step-by-step guide to loading a programming into the Atmel AVR® Board.

Follow these instructions to test the Atmel AVR® Board

- 1) Ensure power is supplied to all the Atmel AVR® Board via the power connector J4.
- 2) Insert EB-004 LED board into Port B of the Atmel AVR® Board
- 3) Ensure that the Atmel AVR® is in correct configuration for programming
  - Jumper links for J9, J10 and J11 are in the position marked “DEFAULT”
  - Ensure that a 11.052MHz crystal is inserted in the Atmel AVR® Board
- 4) AVRISP connected to PC and J3 of AVR Board
  - Connect RS232 style cable (cable provided) to PC and to AVRISP box (grey box)
  - Connect grey header socket (6-way) to J3 of AVR Board  
Ensure the cable is placed with the tab to the outside of the AVR board (this orientation of the header is shown on the AVR Board silk screen)  
*For details on AVRISP connector see ‘Programming – Hardware’ in chapter 5*
- 5) Open AVR studio Software
- 6) Cancel the pop-up window to open any project / files
- 7) Click on the AVR programming symbol 
- 8) Select AT90S1200 device form “Device” pop-down window
- 9) Select the “...” button in the Flash section as shown below

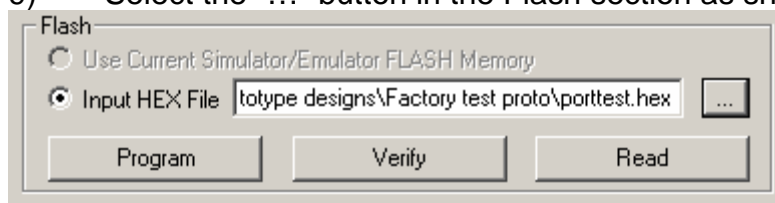

- 10) Navigate to the program *90S1200.hex*
- 11) Press the program button. This will program the AT90S1200 with the test program *90S1200.hex*
- 12) Press the “RESET” button (PB1) on the AVR Board
- 13) Check the illumination of all LEDs

This should satisfy that the Atmel AVR® Board is fully functional!

## Ensuring correct polarity for power supply

### Positive Inner/Positive Outer polarity

To set up the correct polarity the connection symbols on the jack need to match those shown below.

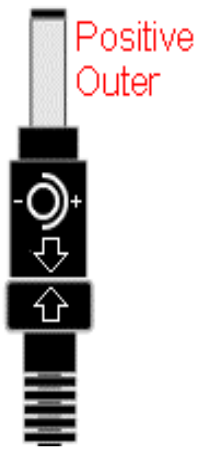
	<h3>Connector dimensions</h3> <p>The PSU is supplied with a number of connectors. The correct connector for Matrix Multimedia products is:</p> <p>Type D 5.0mm external diameter 2.1mm internal diameter</p> <p>“D” is marked on one side, down by the pins, and “5.0x2.1” is marked on the other side.</p> <p><b>EB-019-00-1 Atmel AVR®(R) Board requires Positive Outer power supply</b></p>
---	--

The two arrows – one on the connector socket and one on the connector pin, help you select the correct side of the power jack, and the symbol shows the correct outer connection.

## 5 Block schematic and description

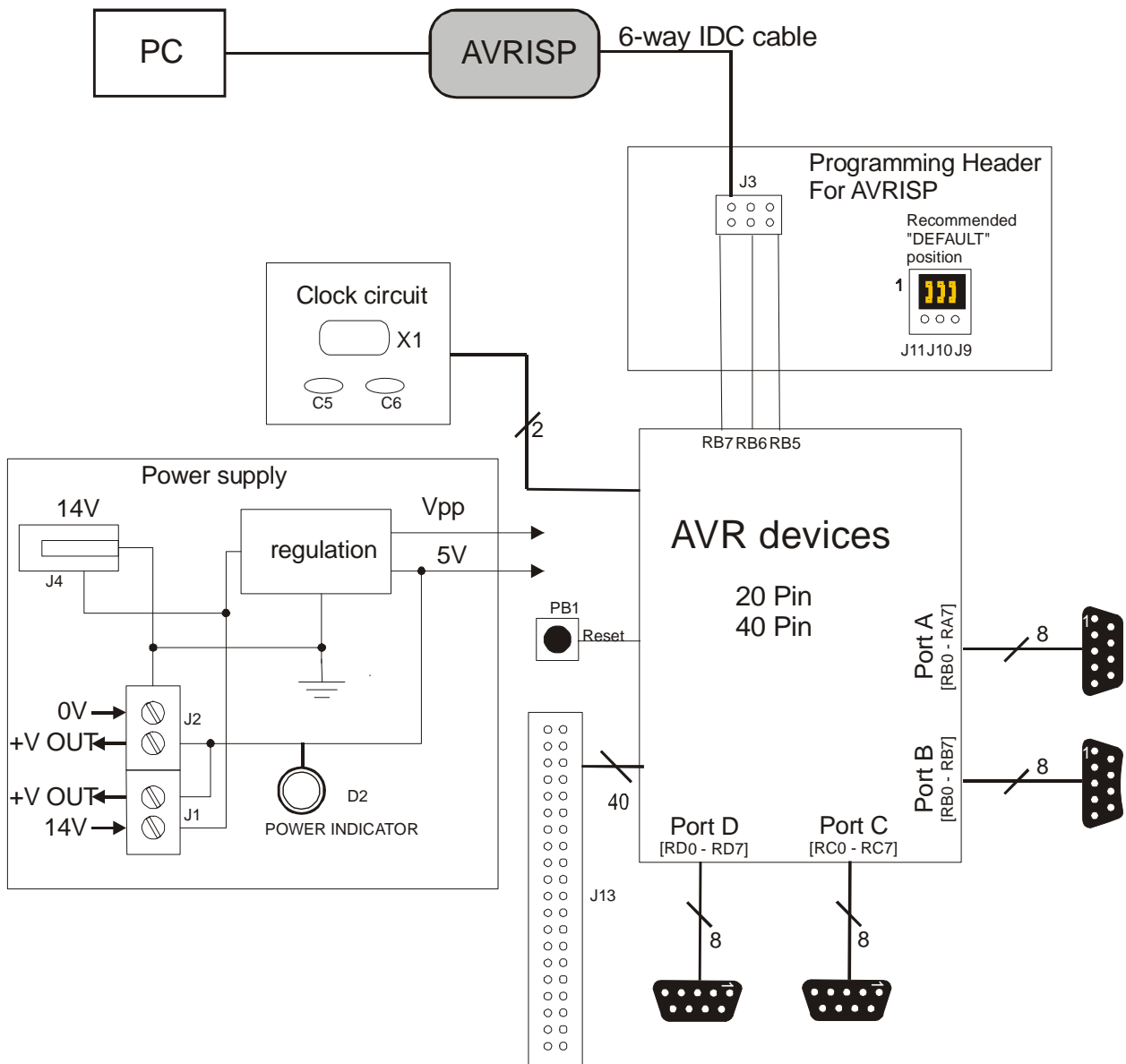

The AVR® Board solution is made up of two parts: A circuit board that allows various slave Atmel AVR® devices to be programmed, and the program to be executed 'seamlessly', and the Windows based programming utility AVR® Studio.



## Power Supply

The board can be powered from an unregulated 14V supply. The regulation circuitry will withstand unregulated 20V as a maximum input voltage and 7V as a minimum. If you are using a DC power supply then you should use a 14V setting. Power can be connected using the 2.1mm power jack (positive outer), or the screw terminal connectors J1, J2. The two “+V OUT” screw terminals are supplied for powering other E-blocks™, supplying approximately +5V. The regulator will supply up to 400mA via all outputs. LED D3 will indicate that power is connected to the board and that the voltage regulation circuitry is fully functional.

*Please note* connector J4 is directly connected to the J1 screw terminal pin 1 labelled ‘+14V’, therefore any voltage input to J4 will also be available direct from pin 1 of J1. This means that ‘+14V’ will not necessarily be +14V

### Note

Remember that other E-blocks will have to receive +5V by placing a connecting wire from the “+V Out” screw terminal of the Multiprogrammer to the “+V” screw terminal of each E-Block that requires a voltage.

## Programming - Hardware

The AVR® Board connects to a personal computer via the AVRISP or compatible device. The AVRISP requires +5V and ground connection these are all provided on the board via the programming header J3.

The following diagram shows the pin-out of the connector J3. The pin-out is the standard pin-out as used by AVRISP.

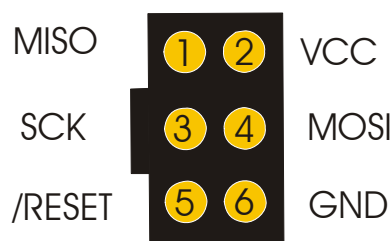

Figure showing Pin-Out of ISP header J3

By default the pins RB5, RB6, and RB7 are used to program the slave AVR® device. These are the pins that provide the programming functions MOSI, MISO and SCK respectively. Due to the nature of programming it is recommended that programming pins have clean signals when programming, therefore there are 120-Ohm resistors between these pins and the associated Port B pins. This is achieved by placing the 3-way link block in the “DEFAULT” mode for J9, J10 and J11. This provides the adequate protection whilst programming.

If problems occur in the programming sequence we recommend completely removing the 3-way jumper link on J9, J10 and J11. This allows MISO, MOSI and SCK to be completely clean whilst

programming. This removes the link to Port B, so pins RB5, RB6 and RB7 are only used for programming.

It is possible to get 100% clean signals on RB5, RB6 and RB7 by placing the 3-way jumper link in the side opposite to that labelled “default” on J9, J10 and J11. Please note that the AVR® devices can NOT be programmed when in this state – this state is only recommended if problems with attachments in Port B occur.

### **Programming - Software**

The CD ROM includes a range of development tools including an Integrated Development Environment for code writing in assembly and debugging, a professional C compiler, and the ISP programming software.

### **DIL Sockets and I / O Ports**

The slave AVR® DIL sockets are wired in parallel (see table of connections below) and the ports are fed out to 4 D-type sockets grouped in ports. These signals are also available on a 40-way header for expansion purposes. Some of the ports will be inactive. This reflects the pin outs of the various AVR® devices themselves. For example, the AT90S1200 only has Port B and Port D, therefore Port A and Port C are inactive. Please refer to device datasheets for availability of port outputs on each device.

*NOTE – Only insert ONE Atmel AVR® device at a time!*

### **Reset Push Button**

PB1 provides a reset by pulling the /RESET pin low. PB1 is pulled normally high through a resistor so that the device will not be reset during normal operation. The programming software has control over the reset line during programming.

### **Frequency Selection**

By default the board is fitted with a 11.0592 MHz crystal. The crystal fits into a small socket, which allows the crystal to be easily changed. These frequencies are chosen as they divide down by AVR® pre-scalers to give suitable frequencies for clock systems and for facilitating serial communication using standard baud rates.

### **USB circuitry**

In the future there may be a possibility of this device being USB compatible. The PCB has been manufactured with the circuitry on board to enable quick development.

*Note this circuitry is not suppose to be populated*

## Appendix A - Circuit Diagram

THIS SYSTEM INCLUDES:-

→ FEET

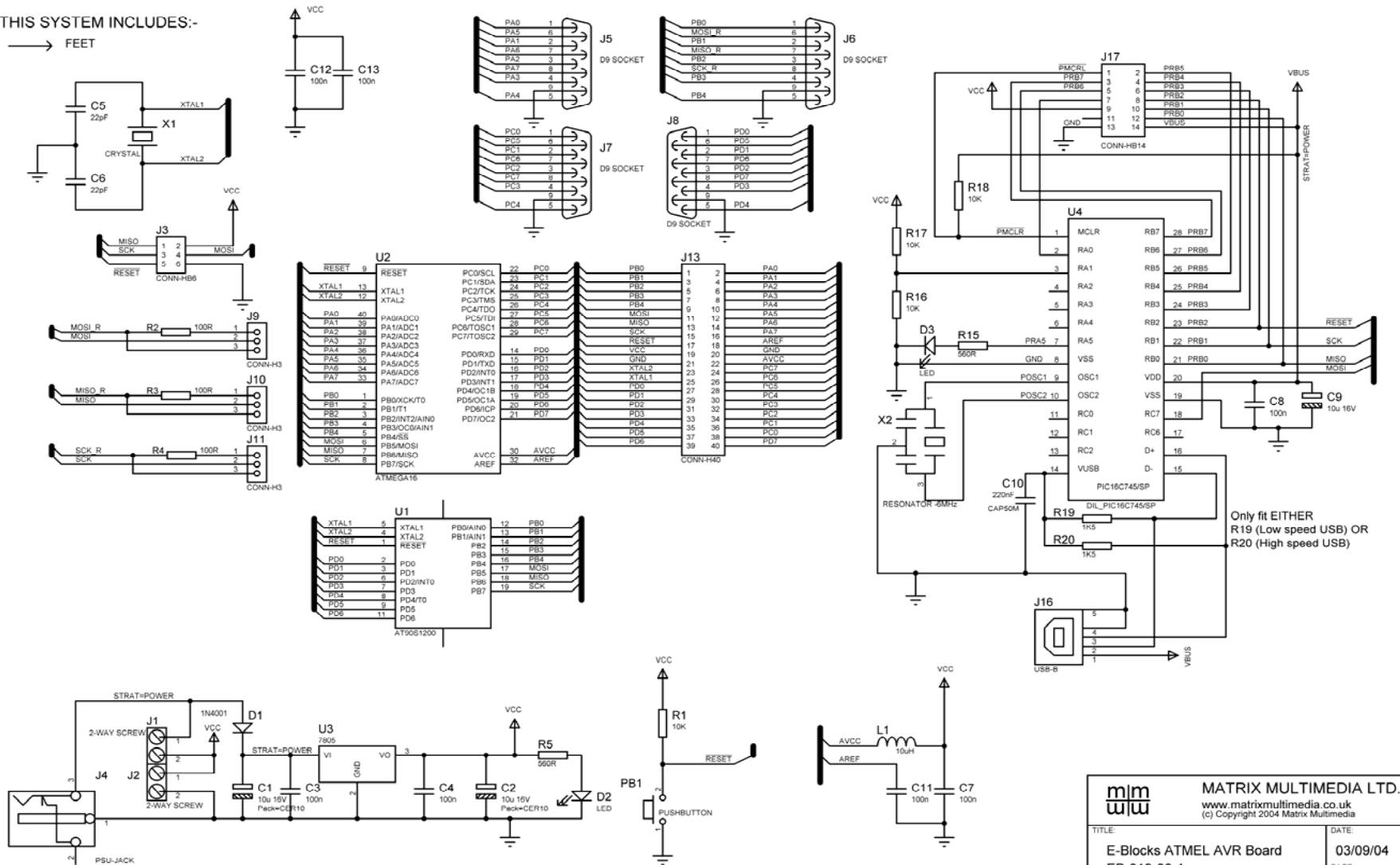

		<b>MATRIX MULTIMEDIA LTD.</b> www.matrixmultimedia.co.uk (c) Copyright 2004 Matrix Multimedia		
TITLE:	E-Blocks ATMEL AVR Board		DATE:	03/09/04
	EB-019-00-1		PAGE:	
BY:	Conor Carr	REV:	1/1	

## Appendix B – Compatible AVR® devices

This board is designed to be as versatile as possible. This means that it has been designed so that it maximizes the amount of AVR® devices that can be used with this board.

The following table shows the AVR® devices that are compatible with this board:

20 –Pin AVR® devices	40 –Pin AVR® devices
90S1200	Mega16L
90s2313	Mega16
Tiny2313	Mega32L
	Mega32
	Mega8535L
	Mega8535
	LS8535
	S8535
	Mega163L
	Mega163
	Mega323L
	Mega323

The items in **Red** are devices that are compatible but are no longer manufactured by Atmel®. These devices can be used but are not recommended.

The following diagram shows the pin-out of 20 and 40 pin AVR® device that are compatible with this board.

### 20 Pin Compatible AVR® Device Pin Out

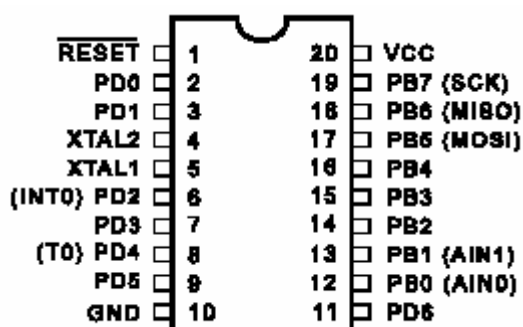

### 40 Pin Compatible AVR® Device Pin Out

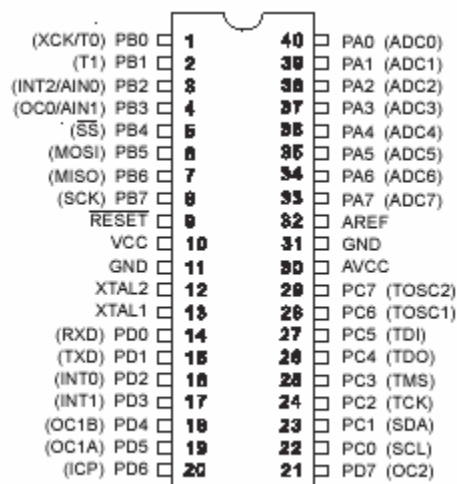

## Appendix C - Bus connections

### Expansion bus

The pin connections on the expansion bus exactly mirror the pin numbering on the 40-pin DIL socket. Note that the pin numbering on the IDC socket is slightly different to that on a DIL socket which results in the seemingly odd arrangement of pins on the IDC pin chart.

### Pin Comparison Chart

Bus Name	Compatible AVR® Pin out	
	20 Pin	40 Pin
VDD	20	10
GND	10	11 & 31
XTAL1	5	13
XTAL2	4	12
/RESET	1	9
RA0		40
RA1		39
RA2		38
RA3		37
RA4		36
RA5		35
RA6		34
RA7		33
RB0	12	1
RB1	13	2
RB2	14	3
RB3	15	4
RB4	16	5
RB5 / MOSI	17	6
RB6 / MISO	18	7
RB7 / SCK	19	8
RC0		22
RC1		23
RC2		24
RC3		25
RC4		26
RC5		27
RC6		28
RC7		29
RD0	2	14
RD1	3	15
RD2	6	16
RD3	7	17
RD4	8	18
RD5	9	19
RD6	11	20
RD7		21
AVCC		30
AREF		32

### Connections on J3 – Programming header

Bus Name	J3
RB5 / MOSI	4
RB6 / MISO	1
RB7 / SCK	3
VDD	2
GND	6
/RESET	5

**Connections on J5 – 40 Pin header connections**

Bus Name	20 Pin Device	40 Pin device	IDC connector
VDD	20	10	19
GND	10	11 & 31	20 & 21
XTAL1	5	13	25
XTAL2	4	12	23
/RESET	1	9	17
RA0		40	2
RA1		39	4
RA2		38	6
RA3		37	8
RA4		36	10
RA5		35	12
RA6		34	14
RA7		33	16
RB0	12	1	1
RB1	13	2	3
RB2	14	3	5
RB3	15	4	7
RB4	16	5	9
RB5 / MOSI	17	6	11
RB6 / MISO	18	7	13
RB7 / SCK	19	8	15
RC0		22	38
RC1		23	36
RC2		24	34
RC3		25	32
RC4		26	30
RC5		27	28
RC6		28	26
RC7		29	24
RD0	2	14	27
RD1	3	15	29
RD2	6	16	31
RD3	7	17	33
RD4	8	18	35
RD5	9	19	37
RD6	11	20	39
RD7		21	40
AVCC		30	18
AREF		32	22