

500mA Output Current, High Speed LDO Regulators,  
Thermal Shutdown Function, Ceramic Capacitor Compatible

## GENERAL DESCRIPTION

The XC6214 series are highly precise, low noise, high current, positive voltage, low dropout voltage regulators. They are fabricated using CMOS process. The series features a voltage reference, an error amplifier, a current limiter, a thermal protection circuit, and a phase compensation circuit plus a driver transistor.

The output voltage is selectable in 1.2V, 1.5V, 1.8V, 2.5V, 3.0V and 3.3V.

The series is also compatible with low ESR ceramic capacitors, which provides stable output voltage. This stability can be maintained even during load fluctuations due to the excellent transient response.

The over current protection circuit and the thermal shutdown circuit are built in. The over current protection circuit will operate when the output current reaches limit current. The thermal shutdown circuit will operate when the junction temperature reaches limit temperature.

## APPLICATIONS

- DVD, CD-ROM, HDD drive equipment
- Portable audio visual equipment  
(Digital Still Cameras, Video Cameras)
- Wireless Communication equipment  
(Mobile Phones, Cordless phones)
- Desktop computers, Note book computer, PDAs
- Network equipment (Wireless LAN)
- Reference voltage
- Battery powered equipment

## FEATURES

- Maximum Output Current** : More than 500mA  
(800mA limit)
- Dropout Voltage** : 500mV @ I<sub>OUT</sub> = 500mA  
(V<sub>OUT</sub>=3.3V)
- Operating Voltage Range** : 1.8V ~ 6.0V
- Output Voltage** : 1.2V, 1.5V, 1.8V, 2.5V, 3.0V, 3.3V  
(standard)  
Other voltages between 1.2V to 5.0V (semi-custom)
- High Accuracy** : Setting voltage accuracy ±2%
- Low Power Consumption** : 8 μA (TYP.)
- Ripple Rejection Rate** : 40dB @ 1kHz
- Operating Temperature** : - 40 ~ 85
- Current Limit Circuit Built-In**
- Thermal Shutdown Circuit Built-In**
- Ceramic Capacitor Compatible**
- Packages** : SOT-89, TO-252
- Environmentally Friendly** : EU RoHS Compliant, Pb Free

## TYPICAL APPLICATION CIRCUIT

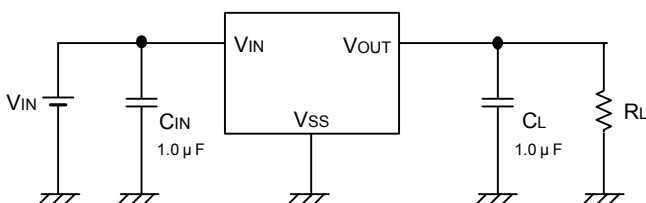

## TYPICAL PERFORMANCE CHARACTERISTICS

Dropout Voltage vs. Output Current

XC6214P332

C<sub>IN</sub>=C<sub>L</sub>=1.0 μF (ceramic)

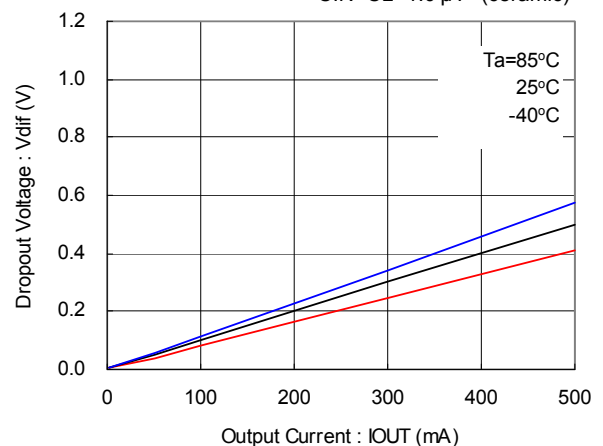

## PIN CONFIGURATION

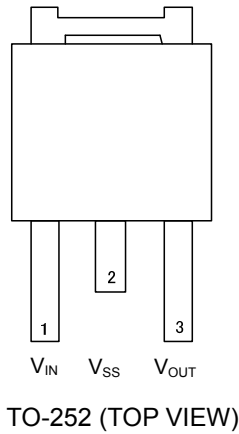
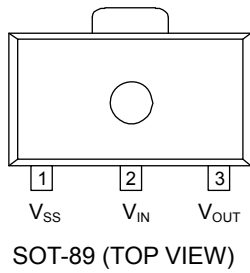

## PIN ASSIGNMENT

PIN NUMBER		PIN NAME	FUNCTIONS
SOT-89	TO-252		
2	1	V <sub>IN</sub>	Power Input
1	2	V <sub>SS</sub>	Ground
-	-	NC	No Connection
3	3	V <sub>OUT</sub>	Output

## PRODUCT CLASSIFICATION

### Ordering Information

XC6214P - <sup>(\*)</sup>

DESIGNATOR	DESCRIPTION	SYMBOL	DESCRIPTION
	Output Voltage	12 ~ 50	ex.) 3.0V products =3, =0
	Output Voltage Accuracy	2	Within ± 2% ex.) 2.50V products =2, =5, =2
-	Packages Taping Type <sup>(**)</sup>	PR	SOT-89
		PR-G	SOT-89
		JR	TO-252

<sup>(\*)</sup> The "-G" suffix indicates that the products are Halogen and Antimony free as well as being fully RoHS compliant.

<sup>(\*\*)</sup> The device orientation is fixed in its embossed tape pocket. For reverse orientation, please contact your local Torex sales office or representative. (Standard orientation: R- , Reverse orientation: L- )

## BLOCK DIAGRAM

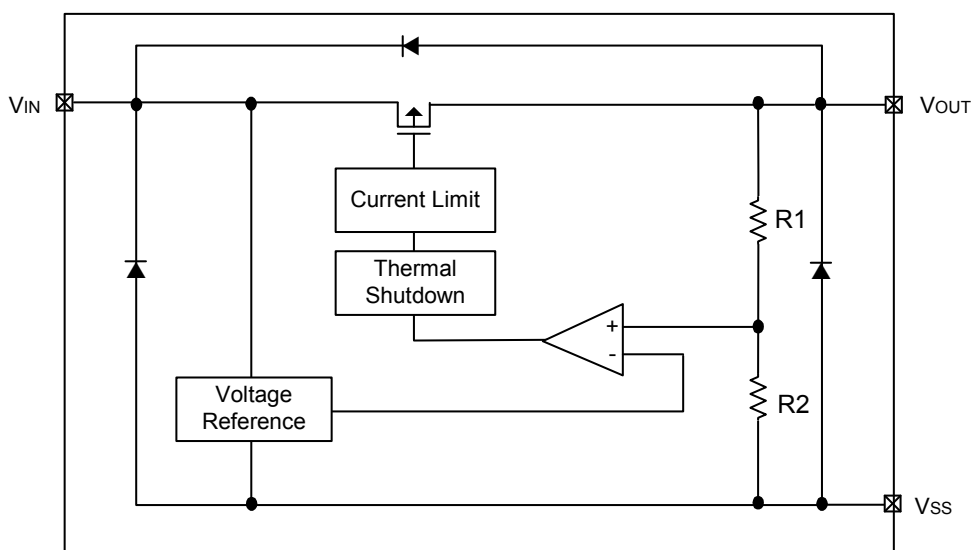

\* Diodes inside the circuit are ESD protection diodes and parasitic diodes.

## ABSOLUTE MAXIMUM RATINGS

Ta=25

PARAMETER	SYMBOL	RATINGS	UNITS
Input Voltage	V <sub>IN</sub>	- 0.3 ~ + 6.5	V
Output Current *	I <sub>OUT</sub>	800 *	mA
Output Voltage	V <sub>OUT</sub>	V <sub>SS</sub> - 0.3 ~ V <sub>IN</sub> + 0.3	V
Power Dissipation	SOT-89	P <sub>d</sub>	mW
	TO-252		
			1800 <sup>(*1)</sup>
Operating Temperature Range	T <sub>opr</sub>	- 40 ~ + 85	
Storage Temperature Range	T <sub>stg</sub>	- 55 ~ + 125	

\* I<sub>OUT</sub> ≤ P<sub>d</sub> / (V<sub>IN</sub> - V<sub>OUT</sub>)

\*1: Refer to POWER DISSIPATION on Page 9.

## ELECTRICAL CHARACTERISTICS

XC6214P122

Ta=25

PARAMETER	SYMBOL	CONDITIONS	MIN.	TYP.	MAX.	UNITS	CIRCUIT
Output Voltage	V <sub>OUT(E)</sub> (*1)	V <sub>IN</sub> =2.2V, I <sub>OUT</sub> =50mA	1.170	1.200	1.230	V	
Maximum Output Current	I <sub>OUTmax</sub>	V <sub>IN</sub> =2.25V, V <sub>OUT</sub> =V <sub>OUT(E)</sub> × 0.90	500	-	-	mA	
Load Regulation	V <sub>OUT</sub>	V <sub>IN</sub> =2.2V, 1mA I <sub>OUT</sub> 200mA	-	20	50	mV	
Dropout Voltage (*2)	V <sub>dif</sub>	I <sub>OUT</sub> =500mA	-	900	1350	mV	
Supply Current	I <sub>SS</sub>	V <sub>IN</sub> =2.5V	-	8	15	μA	
Line Regulation	$\frac{V_{OUT}}{V_{IN} \cdot V_{OUT}}$	I <sub>OUT</sub> =50mA 2.5V V <sub>IN</sub> 6.0V	-	0.05	0.20	% / V	
Input Voltage	V <sub>IN</sub>		1.8	-	6.0	V	-
Output Voltage Temperature Characteristics	$\frac{V_{OUT}}{T_{opr} \cdot V_{OUT}}$	I <sub>OUT</sub> =50mA - 40 T <sub>opr</sub> 85	-	± 100	-	ppm /	
Short-Circuit Current	I <sub>lim</sub>	V <sub>IN</sub> =2.2V, V <sub>OUT</sub> =0V	-	50	-	mA	

NOTE:

- \*1: V<sub>OUT(E)</sub>: Effective output voltage (i.e. the output voltage when “V<sub>OUT(T)</sub>+1.0V” is provided at the V<sub>IN</sub> pin while maintaining a certain I<sub>OUT</sub> value.)
- \*2: V<sub>dif</sub>={V<sub>IN1</sub><sup>(4)</sup> -V<sub>OUT1</sub><sup>(3)</sup>}
- \*3: V<sub>OUT1</sub>= A voltage equal to 98% of the output voltage whenever an amply stabilized I<sub>OUT</sub> {V<sub>OUT(T)</sub>+1.0V} is input.
- \*4: V<sub>IN1</sub>=The Input Voltage when V<sub>OUT1</sub> appears as input voltage is gradually decreased.
- \*5: Unless otherwise stated, {V<sub>IN</sub>=V<sub>OUT(T)</sub> +1.0V}

XC6214P152

Ta=25

PARAMETER	SYMBOL	CONDITIONS	MIN.	TYP.	MAX.	UNITS	CIRCUIT
Output Voltage	V <sub>OUT(E)</sub> (*1)	V <sub>IN</sub> =2.5V, I <sub>OUT</sub> =50mA	1.470	1.500	1.530	V	
Maximum Output Current	I <sub>OUTmax</sub>	V <sub>IN</sub> =2.5V, V <sub>OUT</sub> =V <sub>OUT(E)</sub> × 0.90	500	-	-	mA	
Load Regulation	V <sub>OUT</sub>	V <sub>IN</sub> =2.5V, 1mA I <sub>OUT</sub> 200mA	-	20	50	mV	
Dropout Voltage (*2)	V <sub>dif</sub>	I <sub>OUT</sub> =500mA	-	800	1200	mV	
Supply Current	I <sub>SS</sub>	V <sub>IN</sub> =2.5V	-	8	15	μA	
Line Regulation	$\frac{V_{OUT}}{V_{IN} \cdot V_{OUT}}$	I <sub>OUT</sub> =50mA 2.5V V <sub>IN</sub> 6.0V	-	0.05	0.20	% / V	
Input Voltage	V <sub>IN</sub>		1.8	-	6.0	V	-
Output Voltage Temperature Characteristics	$\frac{V_{OUT}}{T_{opr} \cdot V_{OUT}}$	I <sub>OUT</sub> =50mA - 40 T <sub>opr</sub> 85	-	± 100	-	ppm /	
Short-Circuit Current	I <sub>lim</sub>	V <sub>IN</sub> =2.5V, V <sub>OUT</sub> =0V	-	50	-	mA	

NOTE:

- \*1: V<sub>OUT(E)</sub>: Effective output voltage (i.e. the output voltage when “V<sub>OUT(T)</sub>+1.0V” is provided at the V<sub>IN</sub> pin while maintaining a certain I<sub>OUT</sub> value.)
- \*2: V<sub>dif</sub>={V<sub>IN1</sub><sup>(4)</sup> -V<sub>OUT1</sub><sup>(3)</sup>}
- \*3: V<sub>OUT1</sub>= A voltage equal to 98% of the output voltage whenever an amply stabilized I<sub>OUT</sub> {V<sub>OUT(T)</sub>+1.0V} is input.
- \*4: V<sub>IN1</sub>=The Input Voltage when V<sub>OUT1</sub> appears as input voltage is gradually decreased.
- \*5: Unless otherwise stated, {V<sub>IN</sub>=V<sub>OUT(T)</sub> +1.0V}

## ELECTRICAL CHARACTERISTICS (Continued)

XC6214P182

Ta=25

PARAMETER	SYMBOL	CONDITIONS	MIN.	TYP.	MAX.	UNITS	CIRCUIT
Output Voltage	V <sub>OUT(E)</sub> (*1)	V <sub>IN</sub> =2.8V, I <sub>OUT</sub> =50mA	1.764	1.800	1.836	V	
Maximum Output Current	I <sub>OUTmax</sub>	V <sub>IN</sub> =2.85V, V <sub>OUT</sub> =V <sub>OUT(E)</sub> × 0.90	500	-	-	mA	
Load Regulation	V <sub>OUT</sub>	V <sub>IN</sub> =2.8V, 1mA I <sub>OUT</sub> 200mA	-	20	50	mV	
Dropout Voltage (*2)	V <sub>dif</sub>	I <sub>OUT</sub> =500mA	-	700	1050	mV	
Supply Current	I <sub>SS</sub>	V <sub>IN</sub> =2.8V	-	8	15	μA	
Line Regulation	$\frac{V_{OUT}}{V_{IN} \cdot V_{OUT}}$	I <sub>OUT</sub> =50mA 2.8V V <sub>IN</sub> 6.0V	-	0.05	0.20	% / V	
Input Voltage	V <sub>IN</sub>		1.8	-	6.0	V	-
Output Voltage Temperature Characteristics	$\frac{V_{OUT}}{Topr \cdot V_{OUT}}$	I <sub>OUT</sub> =50mA - 40 Topr 85	-	± 100	-	ppm /	
Short-Circuit Current	I <sub>lim</sub>	V <sub>IN</sub> =2.8V, V <sub>OUT</sub> =0V	-	50	-	mA	

**NOTE:**

\*1: V<sub>OUT(E)</sub>: Effective output voltage (i.e. the output voltage when "V<sub>OUT(T)</sub>+1.0V" is provided at the V<sub>IN</sub> pin while maintaining a certain I<sub>OUT</sub> value.)

\*2: V<sub>dif</sub>={V<sub>IN1</sub><sup>(\*4)</sup> -V<sub>OUT1</sub><sup>(\*3)</sup>}

\*3: V<sub>OUT1</sub>= A voltage equal to 98% of the output voltage whenever an amply stabilized I<sub>OUT</sub> {V<sub>OUT(T)</sub>+1.0V} is input.

\*4: V<sub>IN1</sub>=The Input Voltage when V<sub>OUT1</sub> appears as input voltage is gradually decreased.

\*5: Unless otherwise stated, {V<sub>IN</sub>=V<sub>OUT(T)</sub> +1.0V}

XC6214P252

Ta=25

PARAMETER	SYMBOL	CONDITIONS	MIN.	TYP.	MAX.	UNITS	CIRCUIT
Output Voltage	V <sub>OUT(E)</sub> (*1)	V <sub>IN</sub> =3.5V, I <sub>OUT</sub> =50mA	2.450	2.500	2.550	V	
Maximum Output Current	I <sub>OUTmax</sub>	V <sub>IN</sub> =3.5V, V <sub>OUT</sub> =V <sub>OUT(E)</sub> × 0.93	500	-	-	mA	
Load Regulation	V <sub>OUT</sub>	V <sub>IN</sub> =3.5V, 1mA I <sub>OUT</sub> 200mA	-	20	50	mV	
Dropout Voltage (*2)	V <sub>dif</sub>	I <sub>OUT</sub> =500mA	-	600	900	mV	
Supply Current	I <sub>SS</sub>	V <sub>IN</sub> =3.5V	-	8	15	μA	
Line Regulation	$\frac{V_{OUT}}{V_{IN} \cdot V_{OUT}}$	I <sub>OUT</sub> =50mA 3.5V V <sub>IN</sub> 6.0V	-	0.05	0.20	% / V	
Input Voltage	V <sub>IN</sub>		1.8	-	6.0	V	-
Output Voltage Temperature Characteristics	$\frac{V_{OUT}}{Topr \cdot V_{OUT}}$	I <sub>OUT</sub> =50mA - 40 Topr 85	-	± 100	-	ppm /	
Short-Circuit Current	I <sub>lim</sub>	V <sub>IN</sub> =3.5V, V <sub>OUT</sub> =0V	-	50	-	mA	

**NOTE:**

\*1: V<sub>OUT(E)</sub>: Effective output voltage (i.e. the output voltage when "V<sub>OUT(T)</sub>+1.0V" is provided at the V<sub>IN</sub> pin while maintaining a certain I<sub>OUT</sub> value.)

\*2: V<sub>dif</sub>={V<sub>IN1</sub><sup>(\*4)</sup> -V<sub>OUT1</sub><sup>(\*3)</sup>}

\*3: V<sub>OUT1</sub>= A voltage equal to 98% of the output voltage whenever an amply stabilized I<sub>OUT</sub> {V<sub>OUT(T)</sub>+1.0V} is input.

\*4: V<sub>IN1</sub>=The Input Voltage when V<sub>OUT1</sub> appears as input voltage is gradually decreased.

\*5: Unless otherwise stated, {V<sub>IN</sub>=V<sub>OUT(T)</sub> +1.0V}

## ELECTRICAL CHARACTERISTICS (Continued)

XC6214P302

Ta=25

PARAMETER	SYMBOL	CONDITIONS	MIN.	TYP.	MAX.	UNITS	CIRCUIT
Output Voltage	V <sub>OUT(E)</sub> (*1)	V <sub>IN</sub> =4.0V, I <sub>OUT</sub> =50mA	2.940	3.000	3.060	V	
Maximum Output Current	I <sub>OUTmax</sub>	V <sub>IN</sub> =4.0V, V <sub>OUT</sub> =V <sub>OUT(E)</sub> × 0.96	500	-	-	mA	
Load Regulation	V <sub>OUT</sub>	V <sub>IN</sub> =4.0V, 1mA I <sub>OUT</sub> 200mA	-	20	50	mV	
Dropout Voltage (*2)	V <sub>dif</sub>	I <sub>OUT</sub> =500mA	-	560	820	mV	
Supply Current	I <sub>SS</sub>	V <sub>IN</sub> =4.0V	-	8	15	μA	
Line Regulation	$\frac{V_{OUT}}{V_{IN} \cdot V_{OUT}}$	I <sub>OUT</sub> =50mA 4.0V V <sub>IN</sub> 6.0V	-	0.05	0.20	% / V	
Input Voltage	V <sub>IN</sub>		1.8	-	6.0	V	-
Output Voltage Temperature Characteristics	$\frac{V_{OUT}}{T_{opr} \cdot V_{OUT}}$	I <sub>OUT</sub> =50mA - 40 T <sub>opr</sub> 85	-	± 100	-	ppm /	
Short-Circuit Current	I <sub>lim</sub>	V <sub>IN</sub> =4.0V, V <sub>OUT</sub> =0V	-	50	-	mA	

NOTE:

- \*1: V<sub>OUT(E)</sub>: Effective output voltage (i.e. the output voltage when “V<sub>OUT(T)</sub>+1.0V” is provided at the V<sub>IN</sub> pin while maintaining a certain I<sub>OUT</sub> value.)
- \*2: V<sub>dif</sub>={V<sub>IN1</sub><sup>(4)</sup> -V<sub>OUT1</sub><sup>(3)</sup>}
- \*3: V<sub>OUT1</sub>= A voltage equal to 98% of the output voltage whenever an amply stabilized I<sub>OUT</sub> {V<sub>OUT(T)</sub>+1.0V} is input.
- \*4: V<sub>IN1</sub>=The Input Voltage when V<sub>OUT1</sub> appears as input voltage is gradually decreased.
- \*5: Unless otherwise stated, {V<sub>IN</sub>=V<sub>OUT(T)</sub> +1.0V}

XC6214P332

Ta=25

PARAMETER	SYMBOL	CONDITIONS	MIN.	TYP.	MAX.	UNITS	CIRCUIT
Output Voltage	V <sub>OUT(E)</sub> (*1)	V <sub>IN</sub> =4.3V, I <sub>OUT</sub> =50mA	3.234	3.300	3.366	V	
Maximum Output Current	I <sub>OUTmax</sub>	V <sub>IN</sub> =4.3V, V <sub>OUT</sub> =V <sub>OUT(E)</sub> × 0.96	500	-	-	mA	
Load Regulation	V <sub>OUT</sub>	V <sub>IN</sub> =4.3V, 1mA I <sub>OUT</sub> 200mA	-	20	50	mV	
Dropout Voltage (*2)	V <sub>dif</sub>	I <sub>OUT</sub> =500mA	-	500	750	mV	
Supply Current	I <sub>SS</sub>	V <sub>IN</sub> =4.3V	-	8	15	μA	
Line Regulation	$\frac{V_{OUT}}{V_{IN} \cdot V_{OUT}}$	I <sub>OUT</sub> =50mA 4.3V V <sub>IN</sub> 6.0V	-	0.05	0.20	% / V	
Input Voltage	V <sub>IN</sub>		1.8	-	6.0	V	-
Output Voltage Temperature Characteristics	$\frac{V_{OUT}}{T_{opr} \cdot V_{OUT}}$	I <sub>OUT</sub> =50mA - 40 T <sub>opr</sub> 85	-	± 100	-	ppm /	
Short-Circuit Current	I <sub>lim</sub>	V <sub>IN</sub> =4.3V, V <sub>OUT</sub> =0V	-	50	-	mA	

NOTE:

- \*1: V<sub>OUT(E)</sub>: Effective output voltage (i.e. the output voltage when “V<sub>OUT(T)</sub>+1.0V” is provided at the V<sub>IN</sub> pin while maintaining a certain I<sub>OUT</sub> value.)
- \*2: V<sub>dif</sub>={V<sub>IN1</sub><sup>(4)</sup> -V<sub>OUT1</sub><sup>(3)</sup>}
- \*3: V<sub>OUT1</sub>= A voltage equal to 98% of the output voltage whenever an amply stabilized I<sub>OUT</sub> {V<sub>OUT(T)</sub>+1.0V} is input.
- \*4: V<sub>IN1</sub>=The Input Voltage when V<sub>OUT1</sub> appears as input voltage is gradually decreased.
- \*5: Unless otherwise stated, {V<sub>IN</sub>=V<sub>OUT(T)</sub> +1.0V}

## TEST CIRCUITS

Circuit

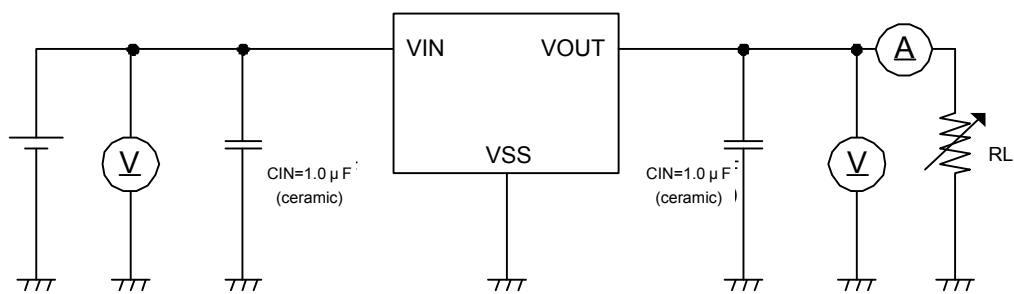

Circuit

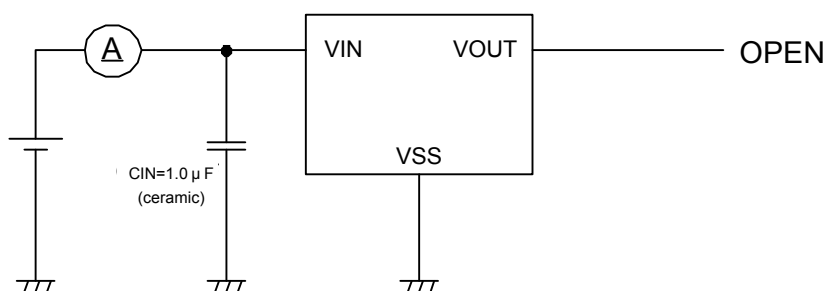

## OPERATIONAL EXPLANATION

### <Output Voltage Regulator Control>

The voltage, divided by resistors R1 & R2, which are connected to the V<sub>OUT</sub> pin is compared with the internal reference voltage by the error amplifier. The P-channel MOSFET, which is connected to the V<sub>OUT</sub> pin, is then driven by the subsequent output signal. The output voltage at the V<sub>OUT</sub> pin is controlled & stabilized by negative feedback. The current limit circuit and over current protection operate in relation to the level of output current and heat.

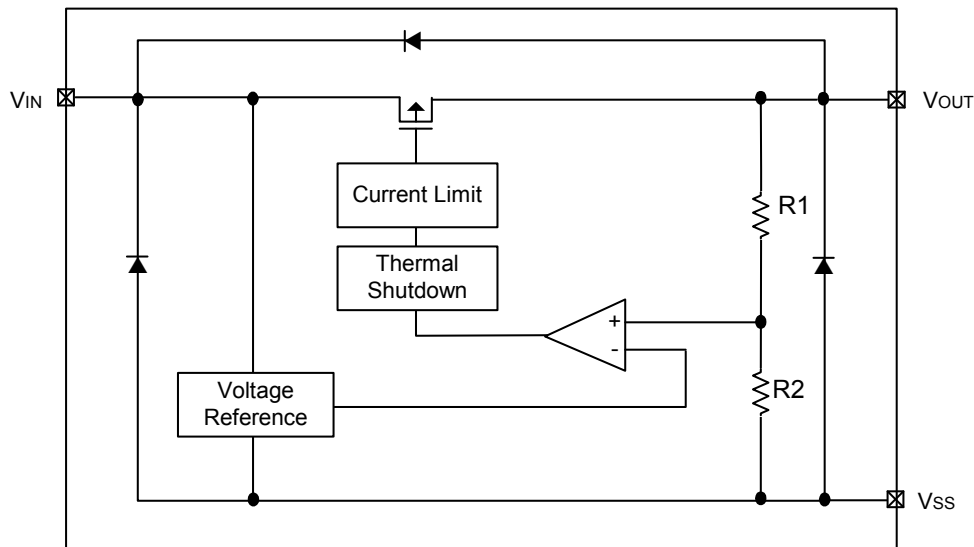

### <Low ESR Capacitors>

With the XC6214 series regulator, a stable output voltage is achievable even if low ESR capacitors are used, as a phase compensation circuit is built-in to the regulator. In order to ensure the stability of the load transient response and line transient response, we suggest that an output capacitor (C<sub>L</sub>) be connected as close as possible, between the output pin (V<sub>OUT</sub>) and the V<sub>SS</sub> pin. Please use an output capacitor (C<sub>L</sub>) with a capacitance more than 0.1 μF. We also suggest an input capacitor (C<sub>IN</sub>) of 0.1 μF: this should be connected between V<sub>IN</sub> and V<sub>SS</sub> in order to stabilize input power source.

### <Current Limiter, Short-Circuit Protection>

The XC6214 series regulator offers a combination of current limit and circuit protection by means of a built-in fixed current limiter circuit and a foldback circuit. When the output pin is shorted, a current of about 50mA flows.

### <Thermal Shutdown>

When the junction temperature of the built-in driver transistor reaches the temperature limit level (150 TYP.), the thermal shutdown circuit operates and the driver transistor will be set to OFF. The thermal shutdown function will be released (automatically recovered) when the junction temperature decreases to the thermal shutdown release temperature level (125 TYP.) and the IC re-starts the operation.

## NOTES ON USE

1. Please use this IC within the stated absolute maximum ratings. The IC is liable to malfunction should the ratings be exceeded.
2. Where wiring impedance is high, operations may become unstable due to noise and/or phase lag depending on output current. Please strengthen V<sub>IN</sub> and V<sub>SS</sub> wiring in particular.
3. Please wire the input capacitor (C<sub>IN</sub>) and the output capacitor (C<sub>L</sub>) as close to the IC as possible.
4. Output voltage may increase when the IC is used at light load current (around 0 to 2 μA) depending on temperature conditions, etc.



## POWER DISSIPATION (TO-252)

### TO-252 Power Dissipation

Power dissipation data for the TO-252 is shown in this page.

The value of power dissipation varies with the mount board conditions.

Please use this data as one of reference data taken in the described condition.

#### 1. Measurement Condition (Reference data)

- Condition: Mount on a board
- Ambient: Natural convection
- Soldering: Lead (Pb) free
- Board: Dimensions 40 x 40 mm (1600 mm<sup>2</sup> in one side)  
Copper (Cu) traces occupy 50% of the board area  
In top and back faces  
Package heat-sink is tied to the copper traces
- Material: Glass Epoxy (FR-4)
- Thickness: 1.6 mm
- Through-hole: 4 x 0.8 Diameter

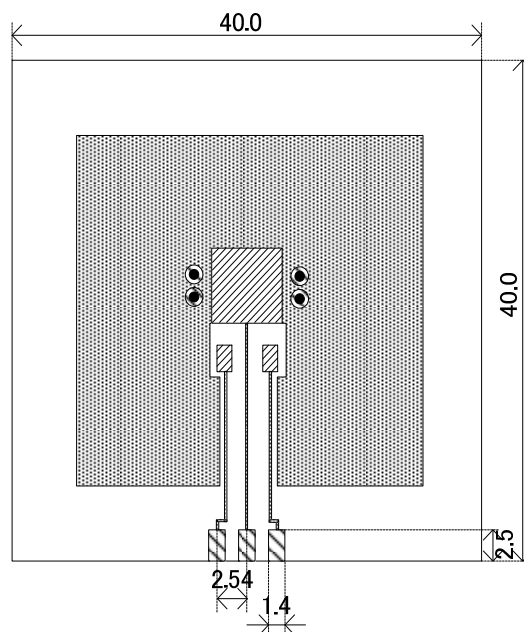

Evaluation Board (Unit: mm)

#### 2. Power Dissipation vs. Operating temperature

Board Mount ( $T_j \text{ max} = 125$  )

Ambient Temperature (°C)	Power Dissipation Pd (mW)	Thermal Resistance (°C/W)
25	1800	55.56
85	720	

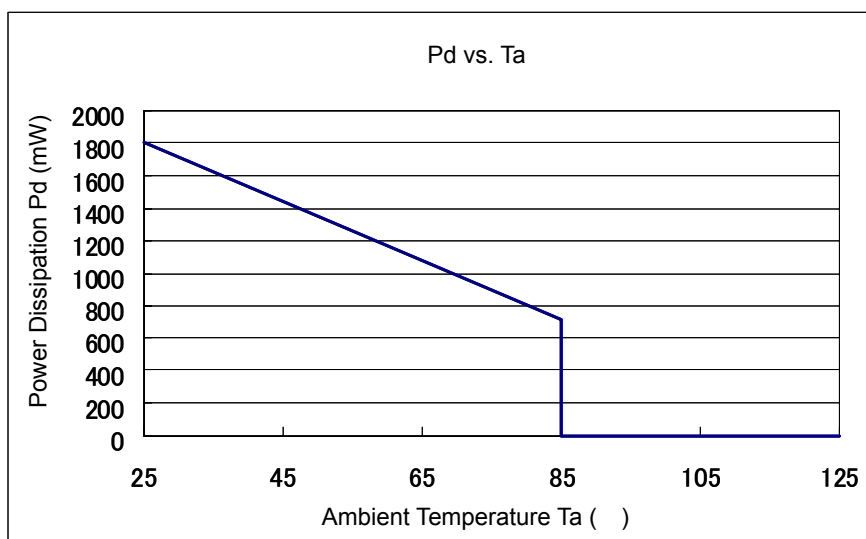

## TYPICAL PERFORMANCE CHARACTERISTICS

(1) Output Voltage vs. Output Current

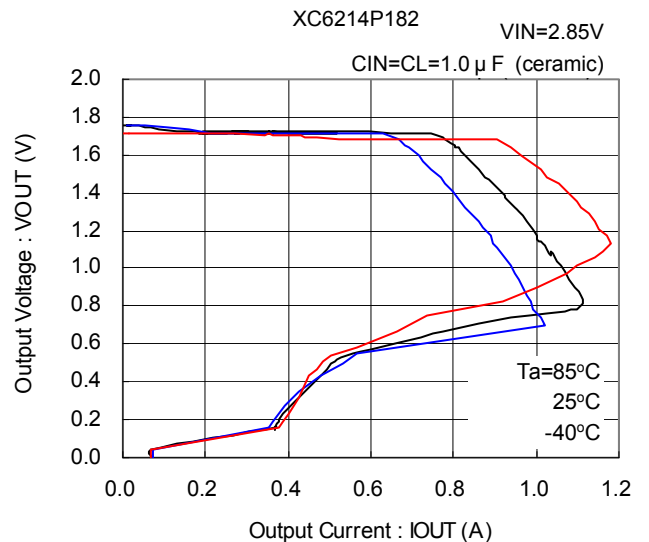
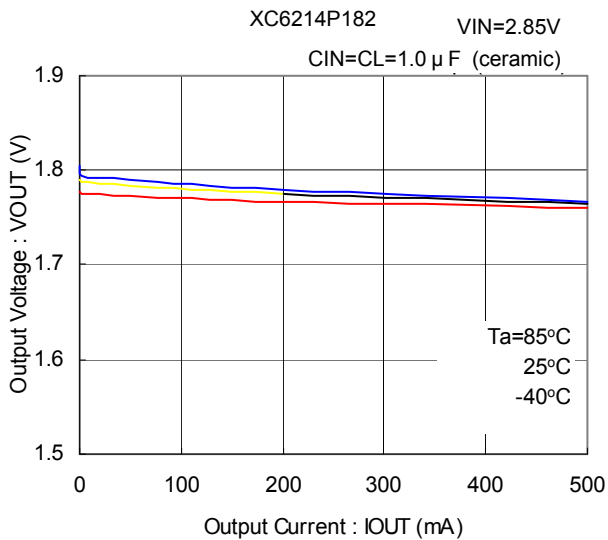
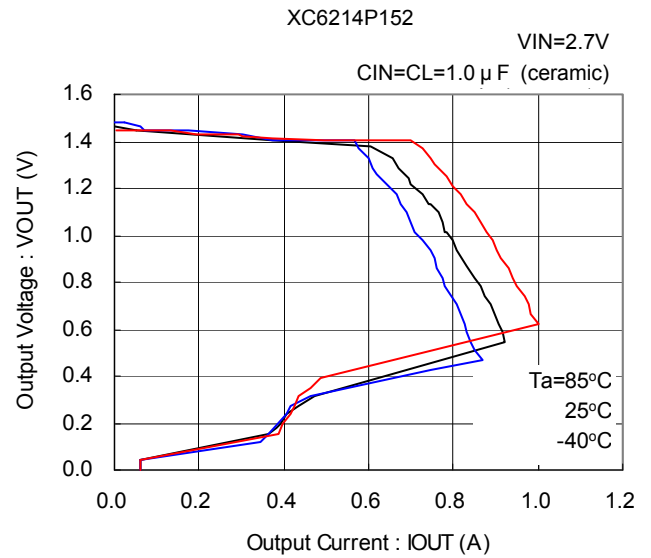
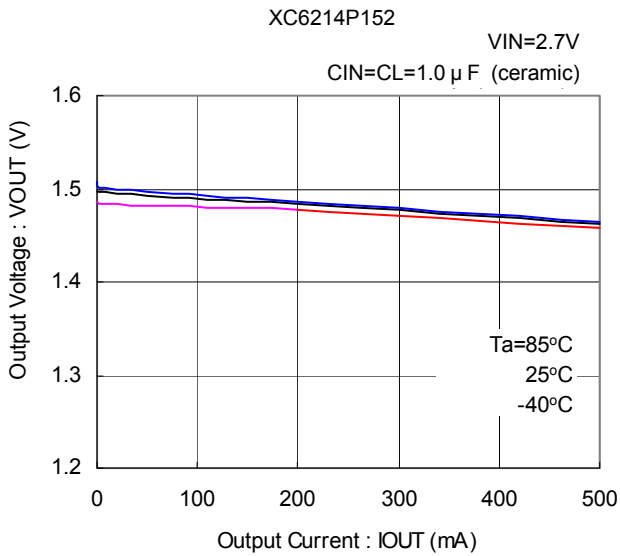
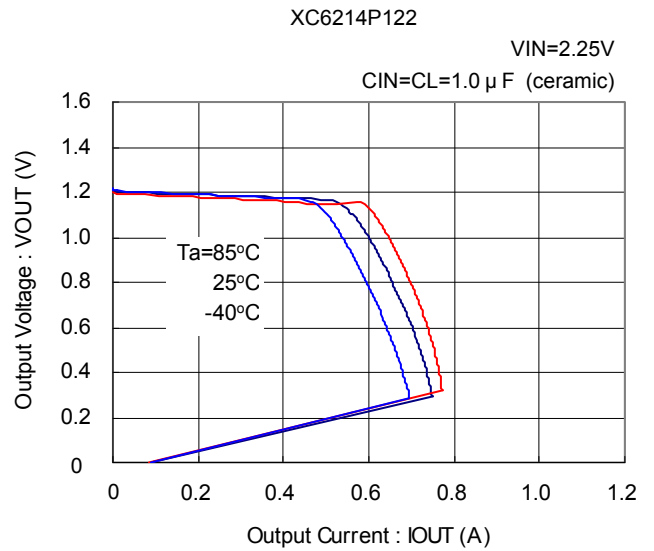
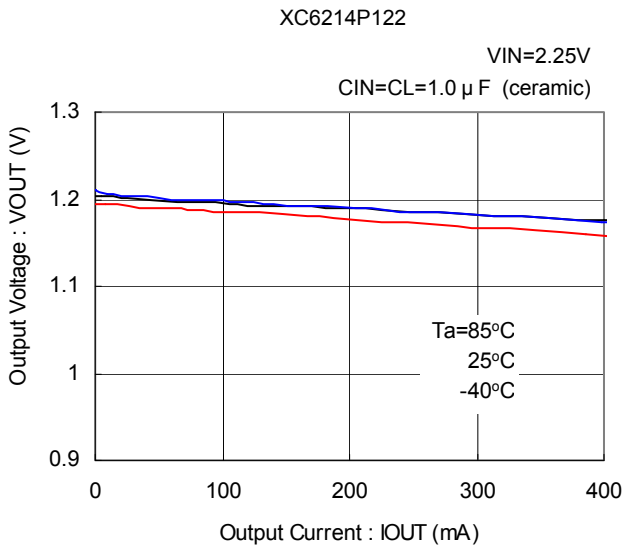

## TYPICAL PERFORMANCE CHARACTERISTICS (Continued)

(1) Output Voltage vs. Output Current (Continued)

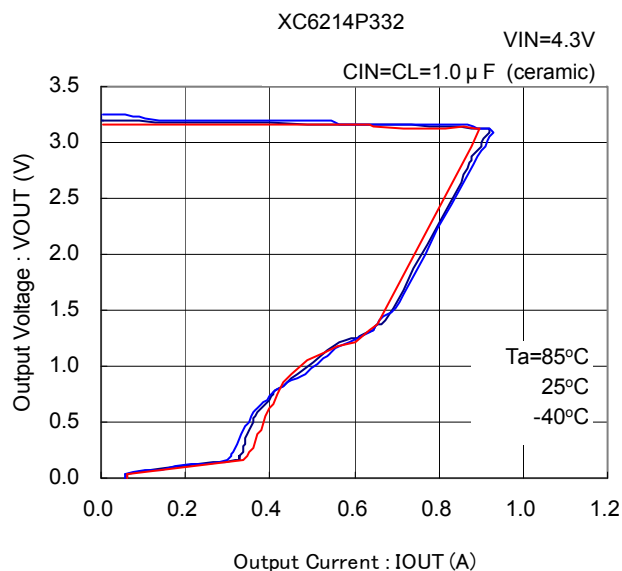
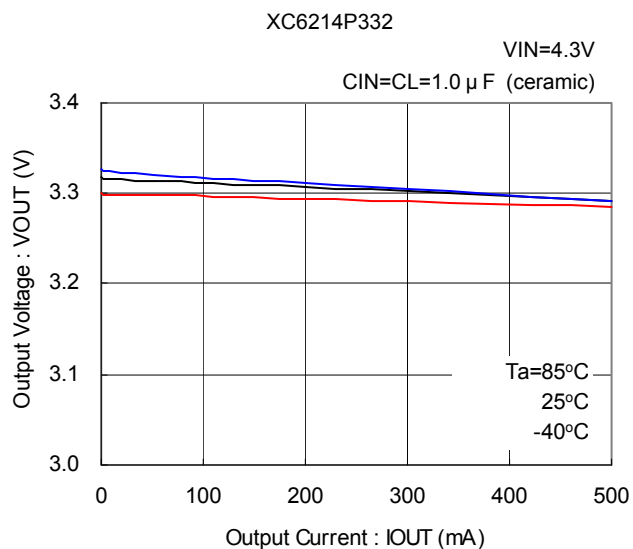
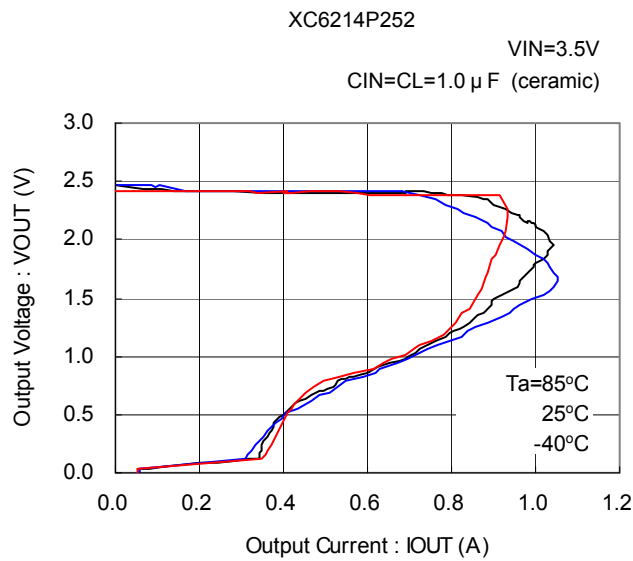
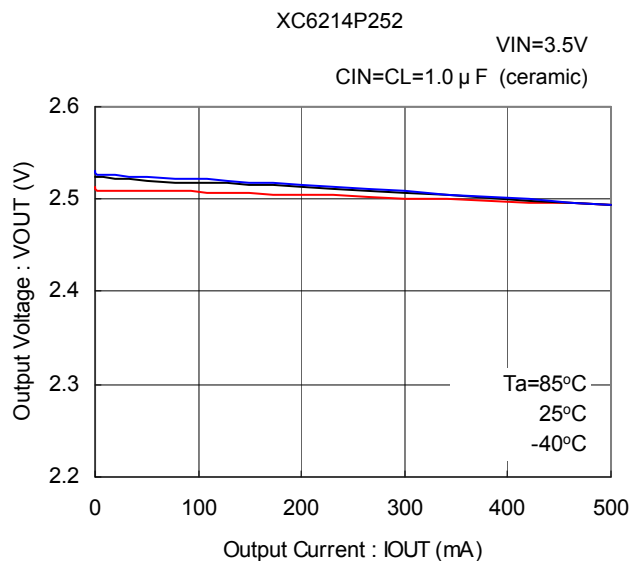

(2) Output Voltage vs. Input Voltage

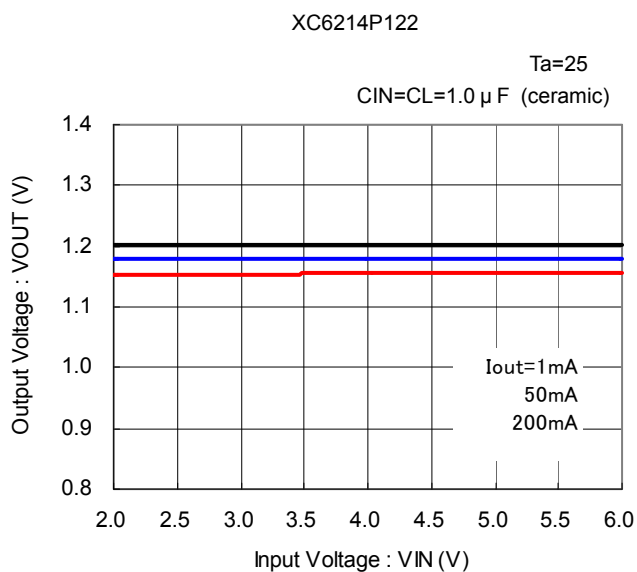
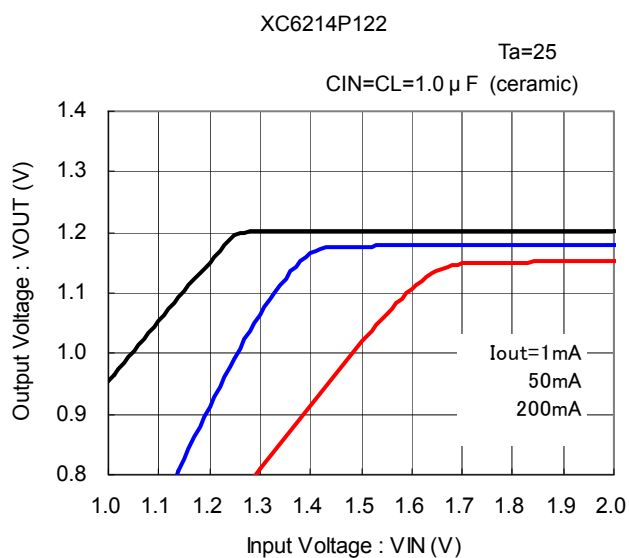

## TYPICAL PERFORMANCE CHARACTERISTICS (Continued)

(2) Output Voltage vs. Input Voltage (Continued)

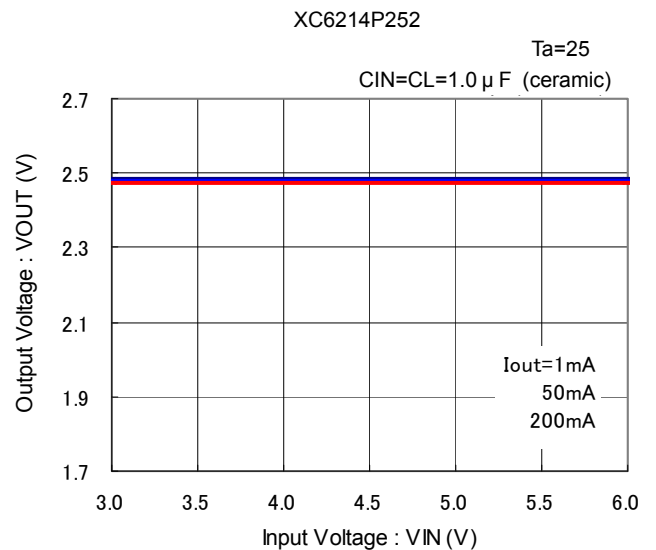
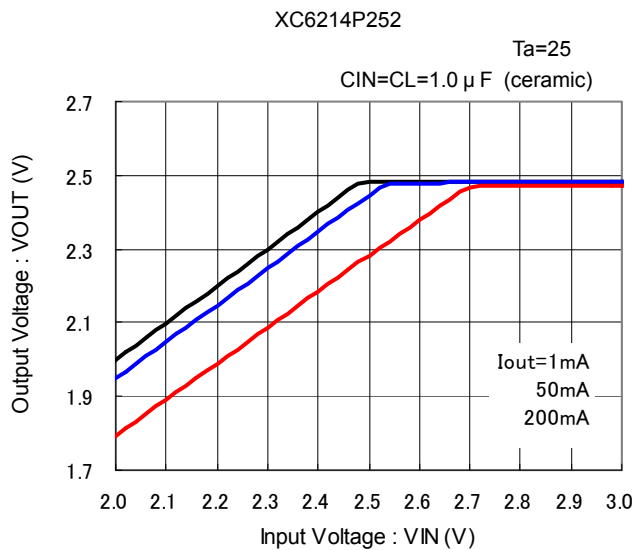
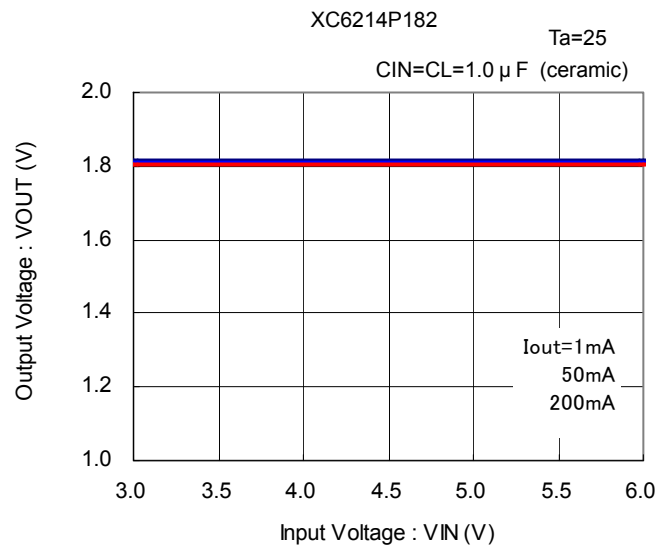
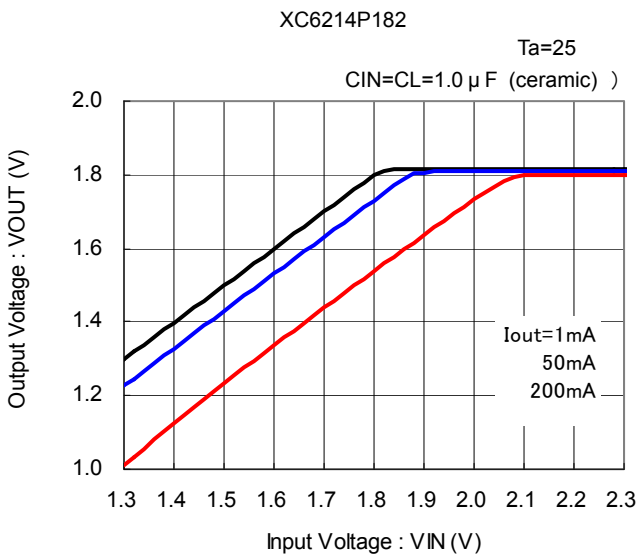
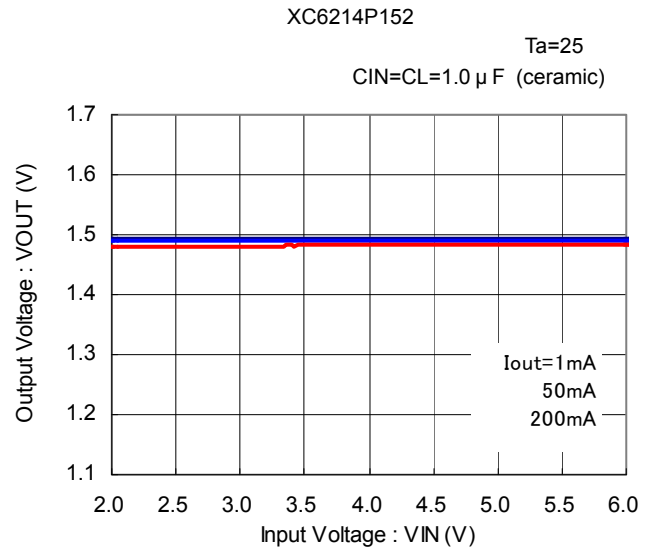
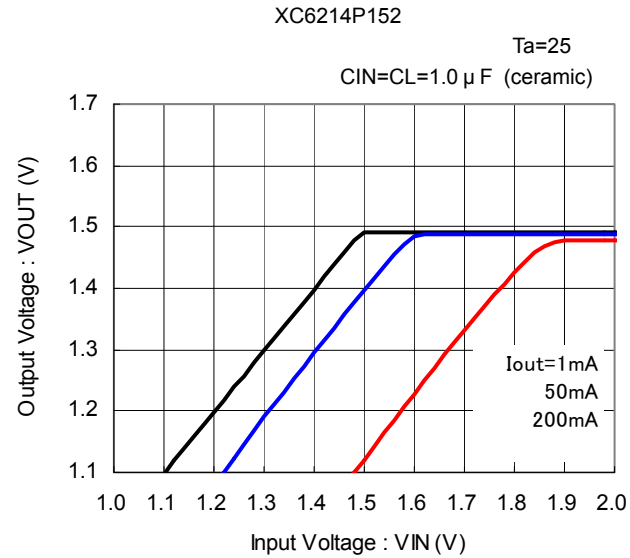

## TYPICAL PERFORMANCE CHARACTER (Continued)

(2) Output Voltage vs. Input Voltage (Continued)

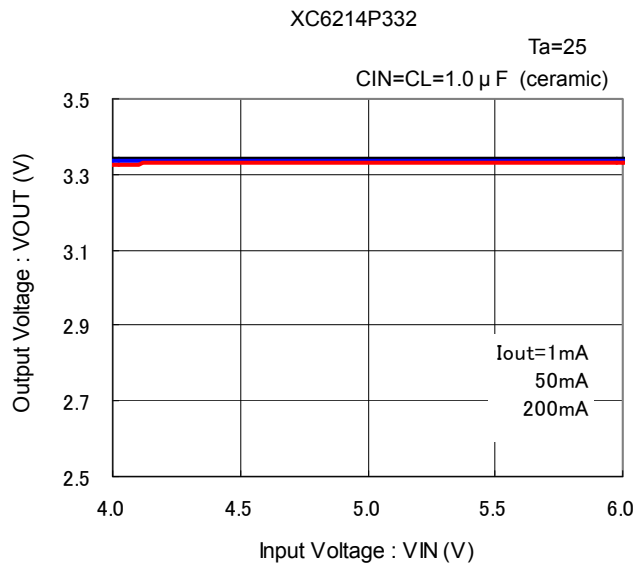
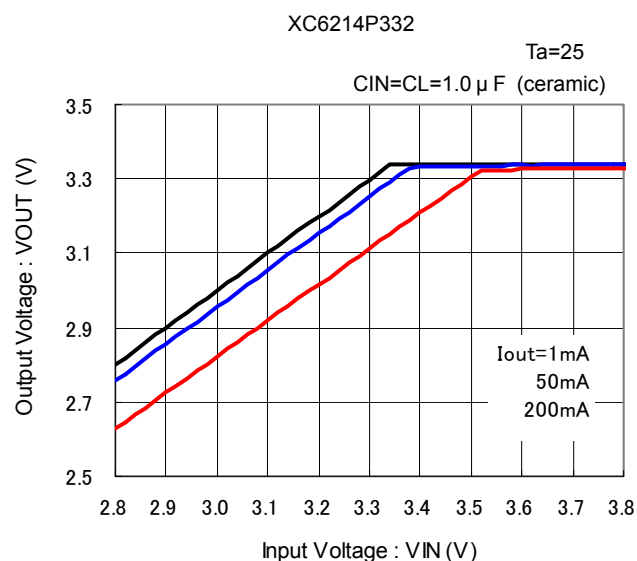

(3) Dropout Voltage vs. Output Current

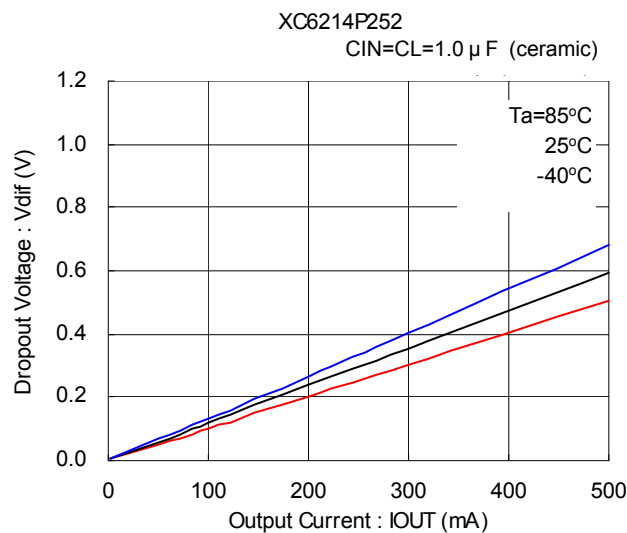
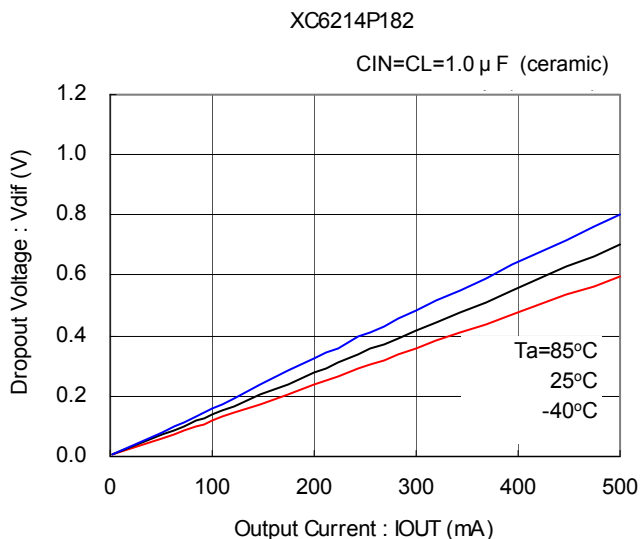
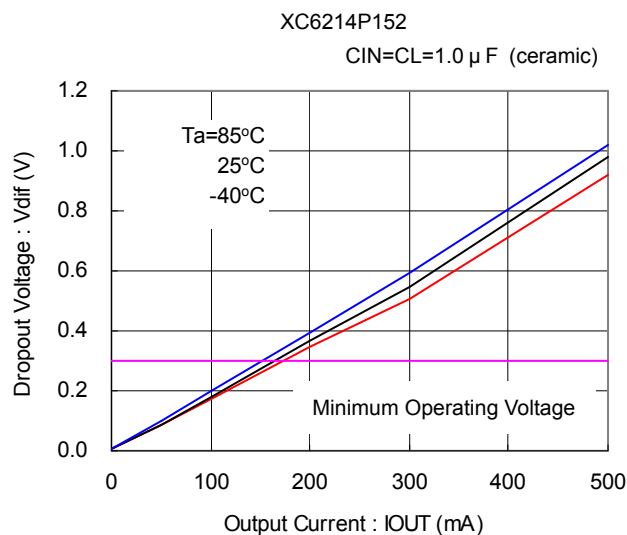
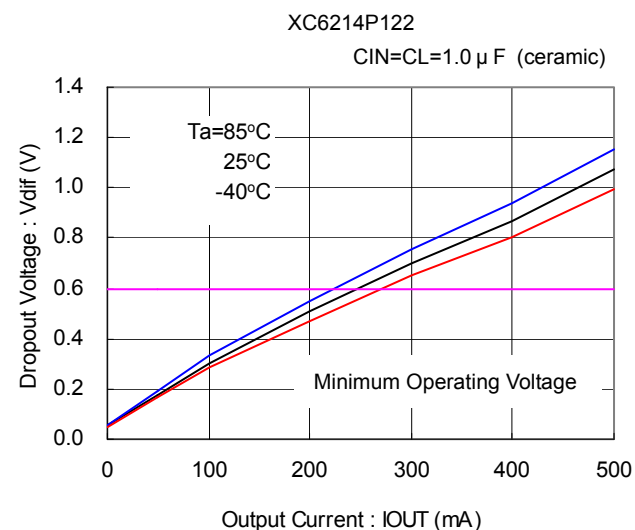

## TYPICAL PERFORMANCE CHARACTERISTICS (Continued)

(3) Dropout Voltage vs. Output Current (Continued)

(4) Supply Current vs. Input Voltage

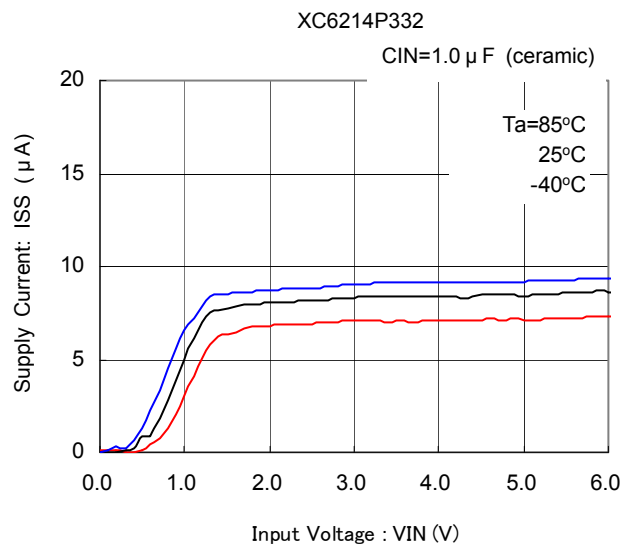
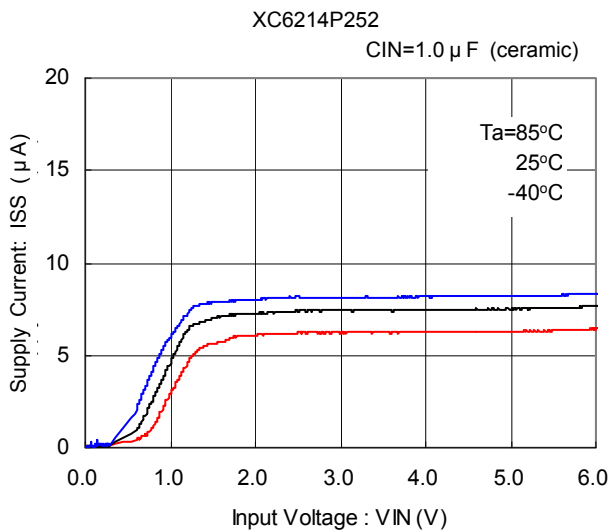
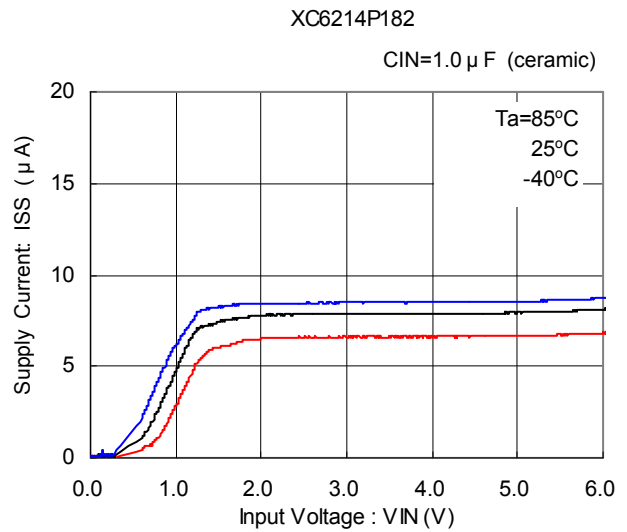
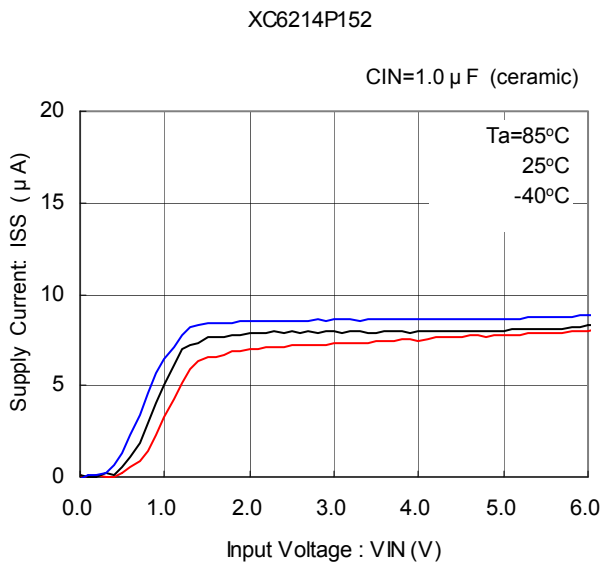
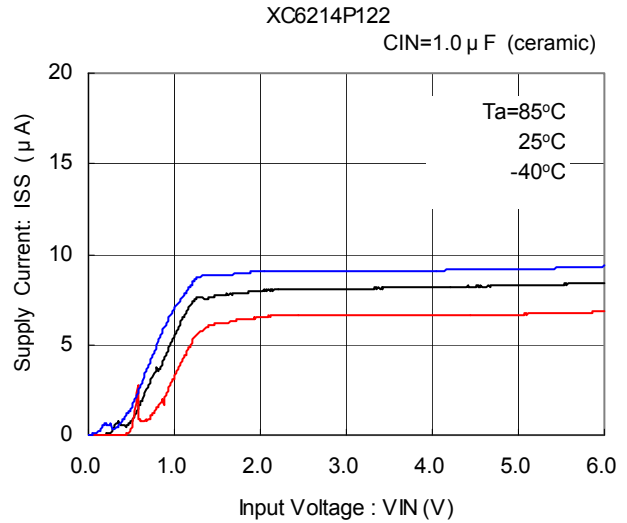
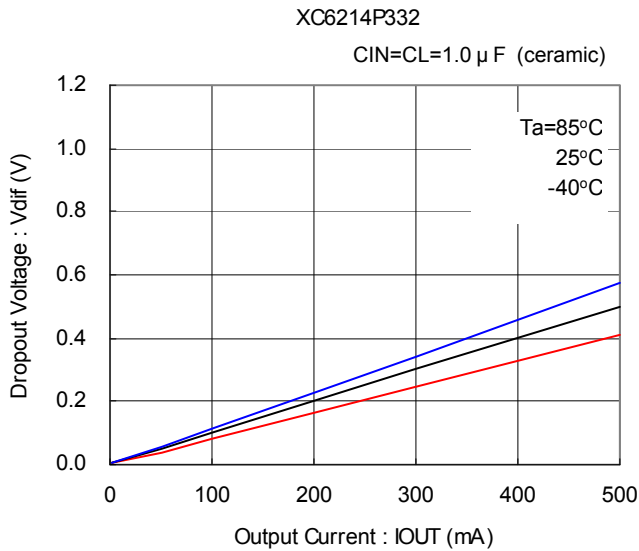

## TYPICAL PERFORMANCE CHARACTERISTICS (Continued)

(5) Output Voltage vs. Ambient Temperature

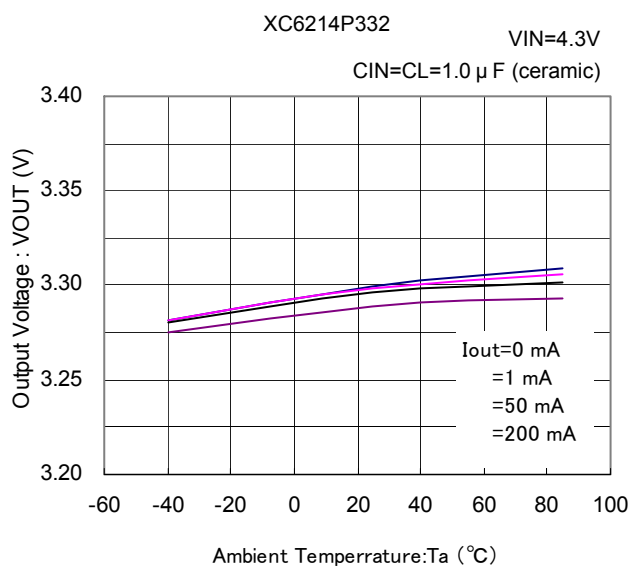
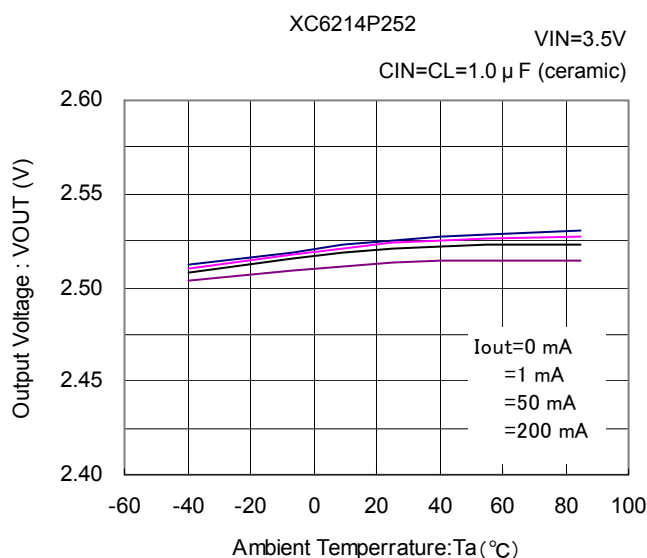
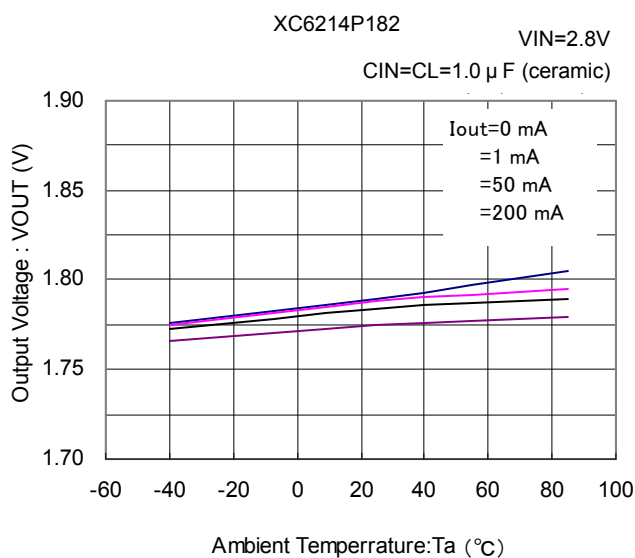
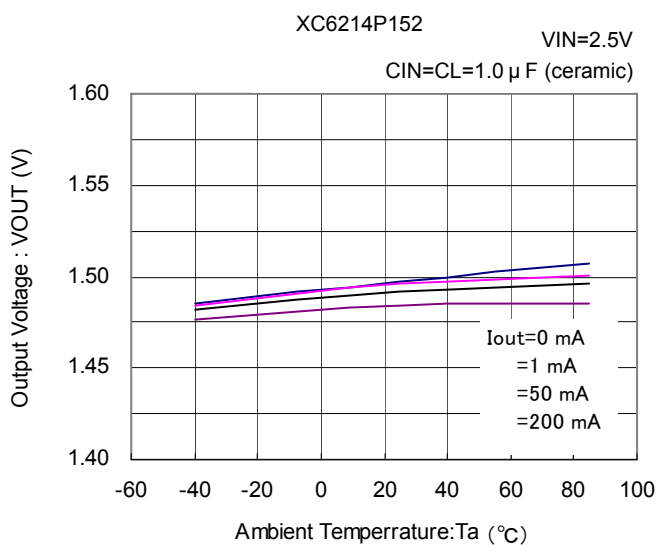
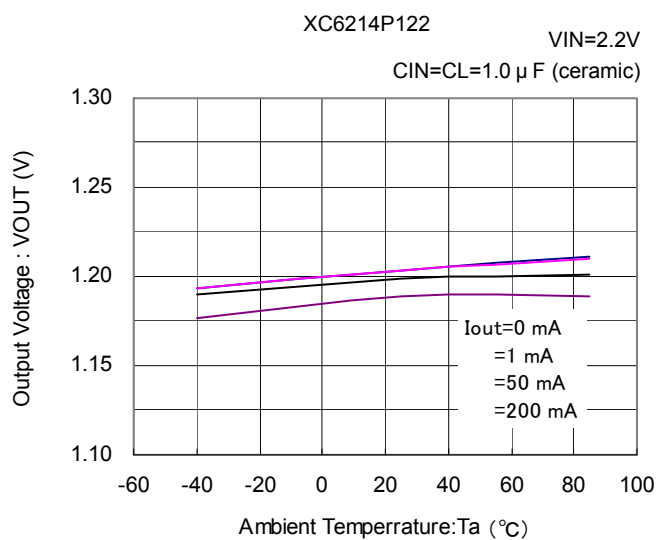

(6) Supply Current vs. Ambient Temperature

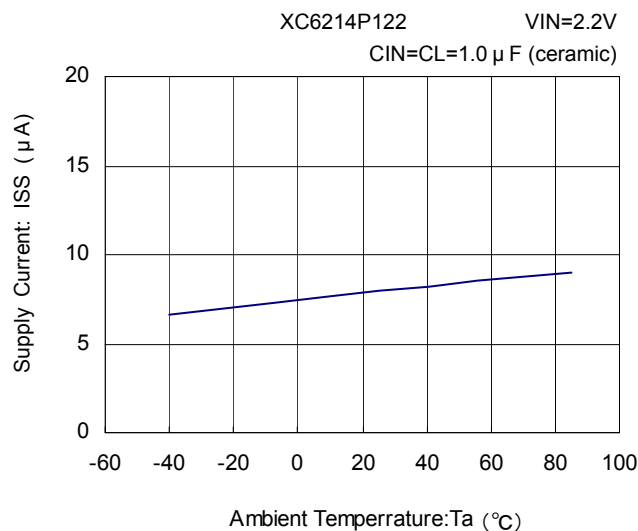

## TYPICAL PERFORMANCE CHARACTERISTICS (Continued)

(6) Supply Current vs. Ambient Temperature (Continued)

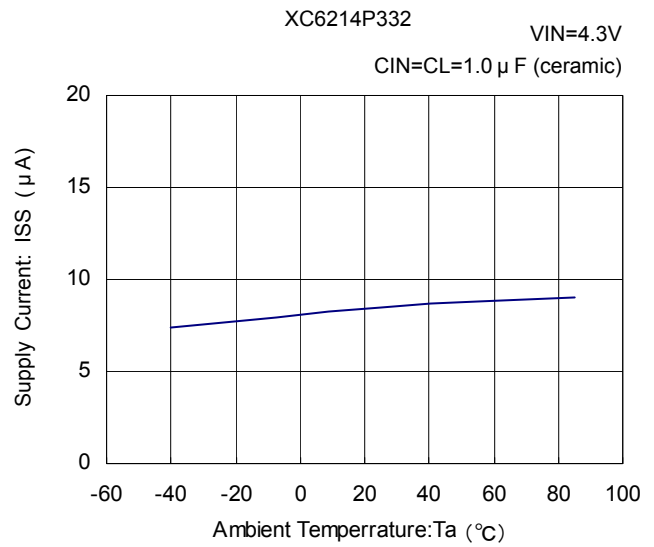
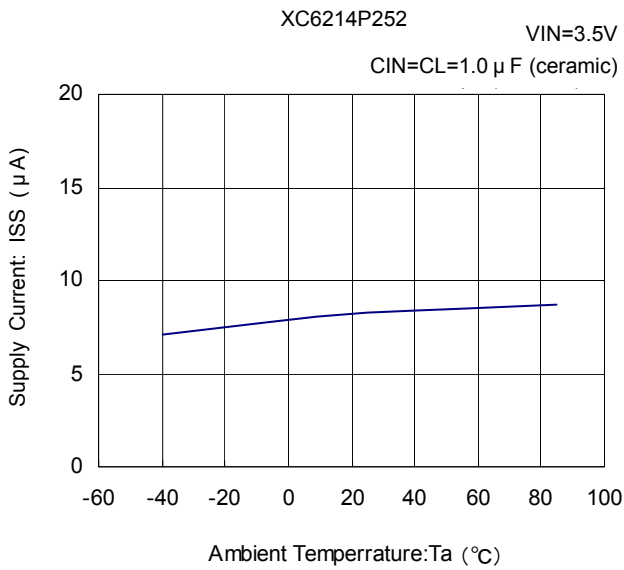
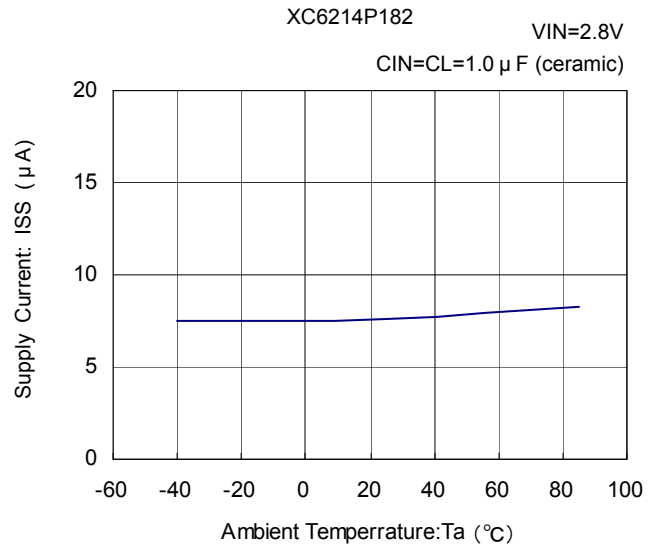
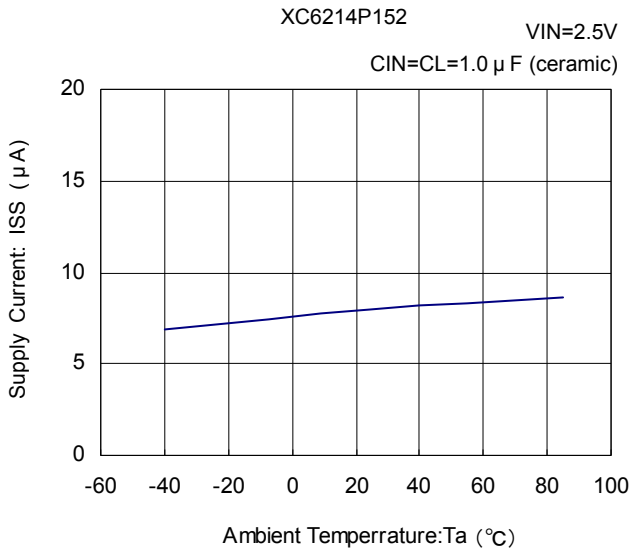



## TYPICAL PERFORMANCE CHARACTERISTICS (Continued)

### (7) Input Transient Response

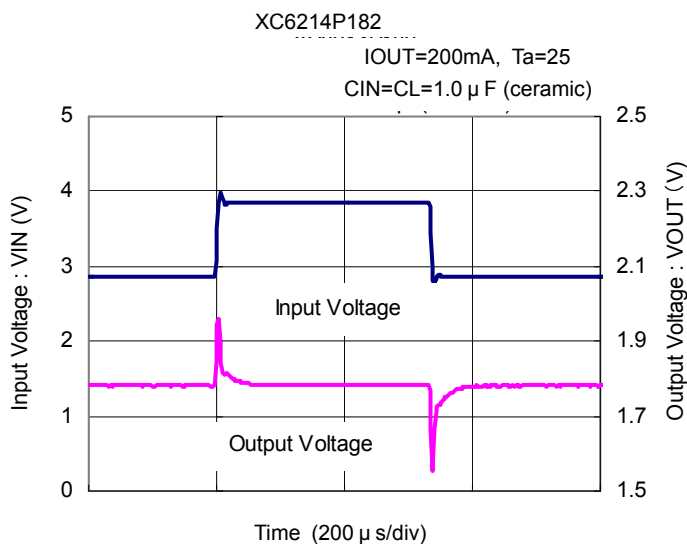
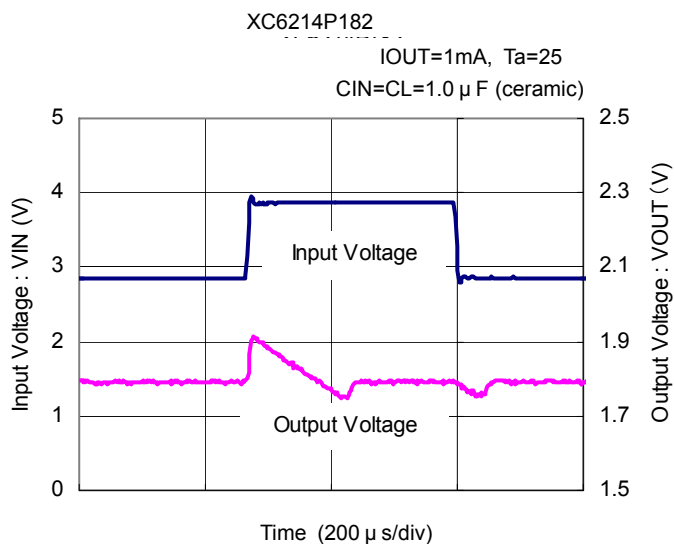
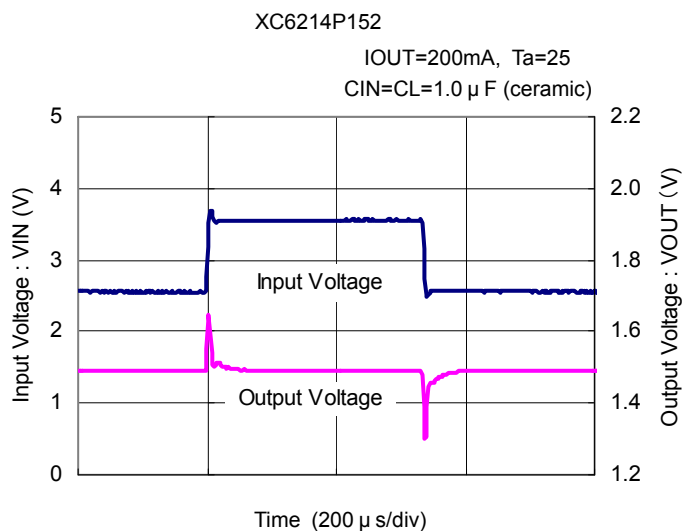
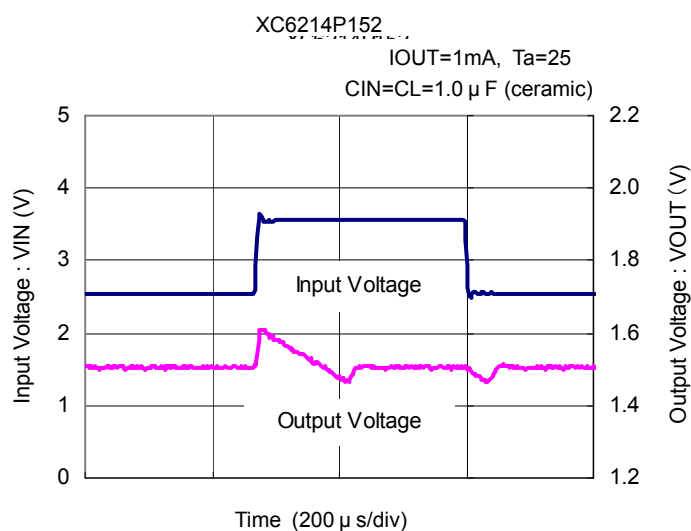
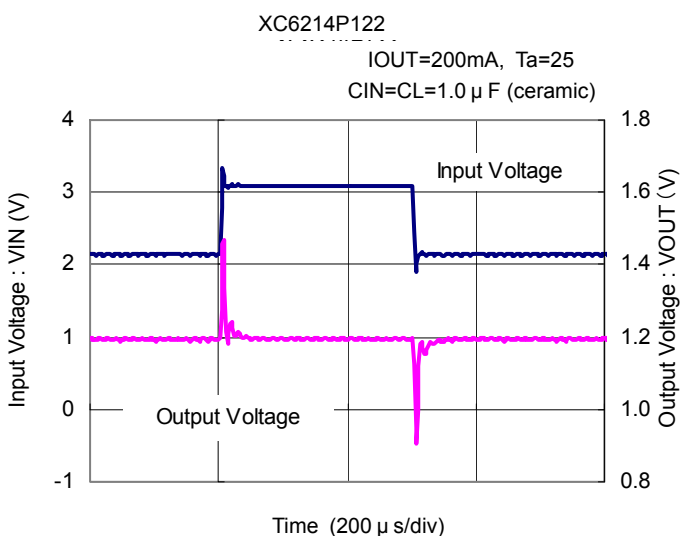
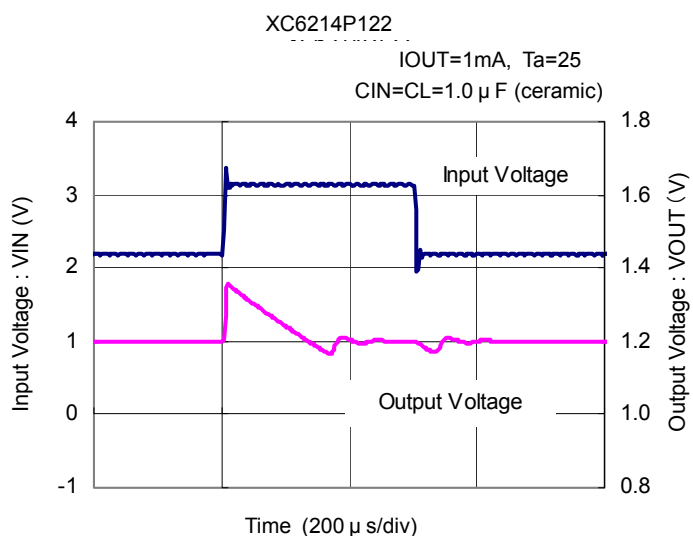

## TYPICAL PERFORMANCE CHARACTERISTICS (Continued)

### (7) Input Transient Response (Continued)

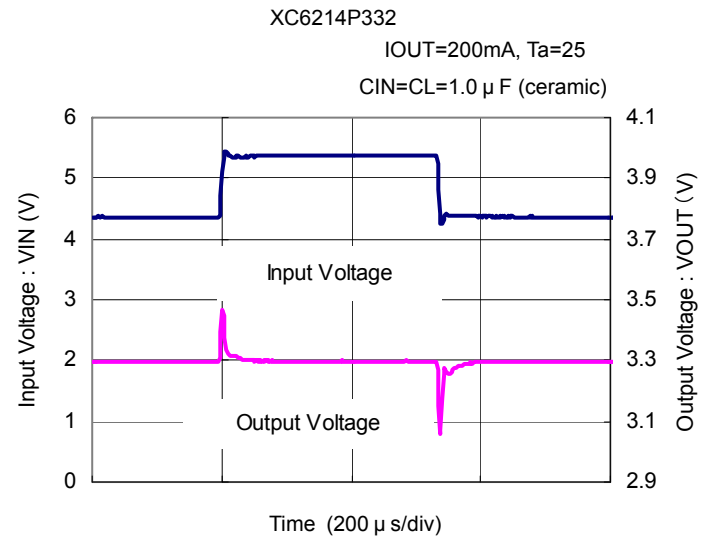
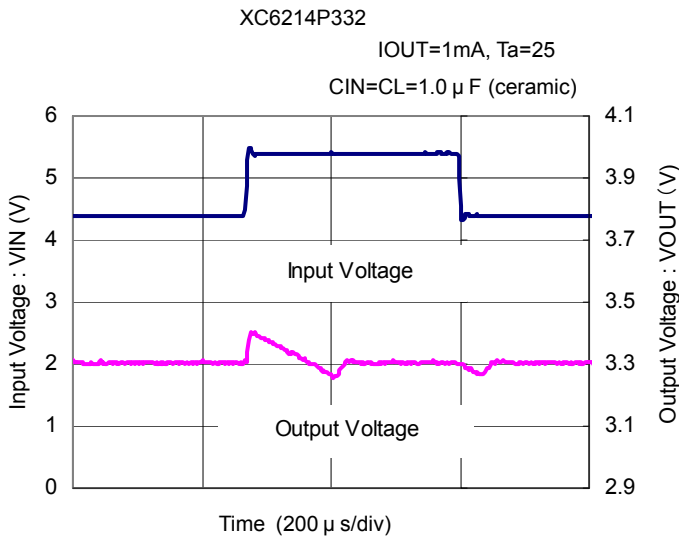
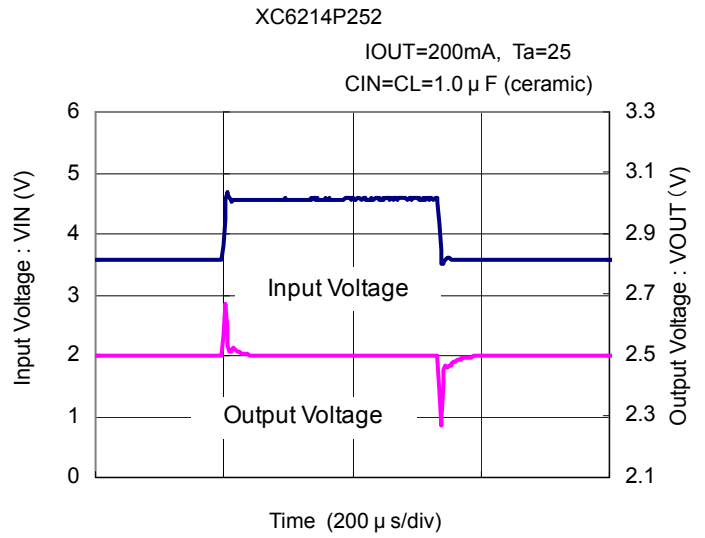
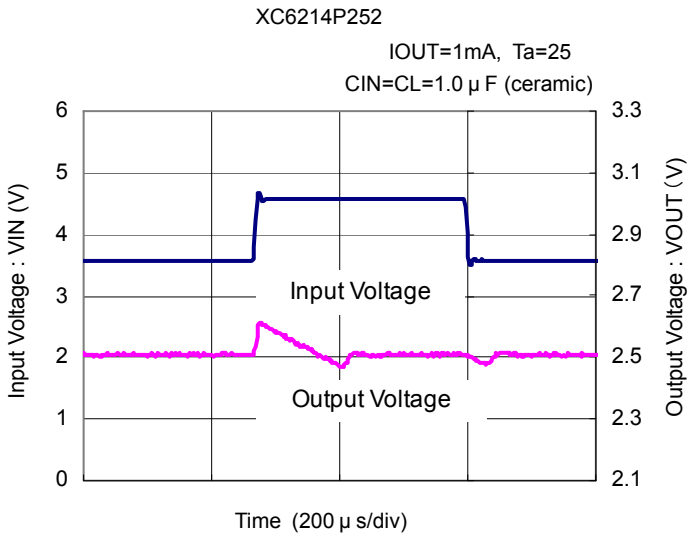

### (8) Load Transient Response

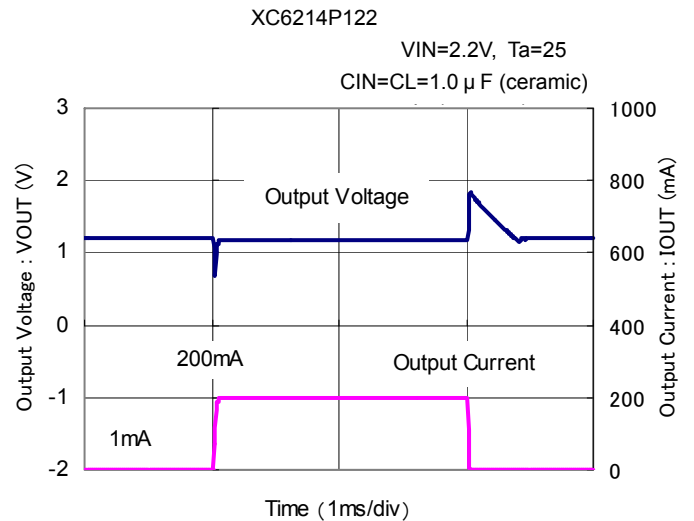
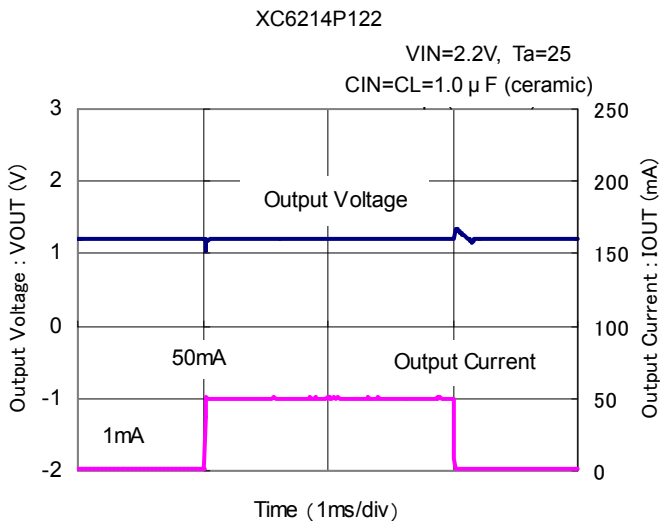

## TYPICAL PERFORMANCE CHARACTERISTICS (Continued)

### (8) Load Transient Response (Continued)

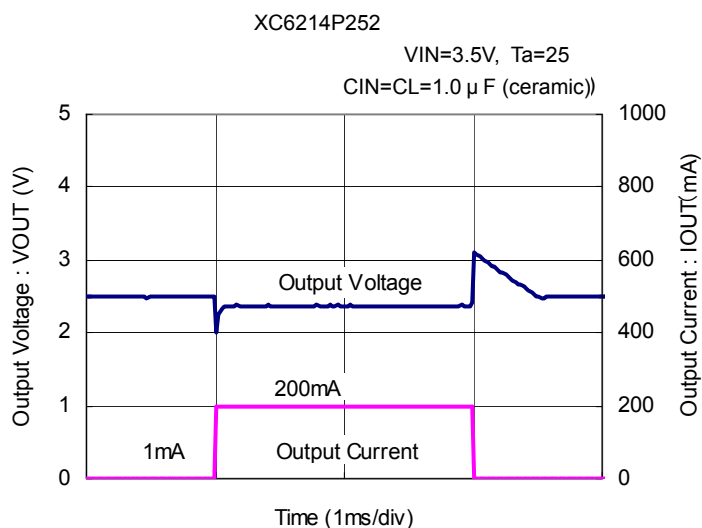
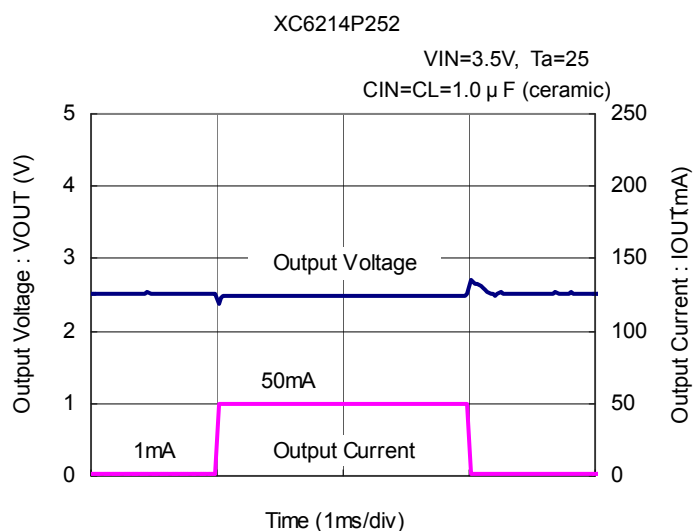
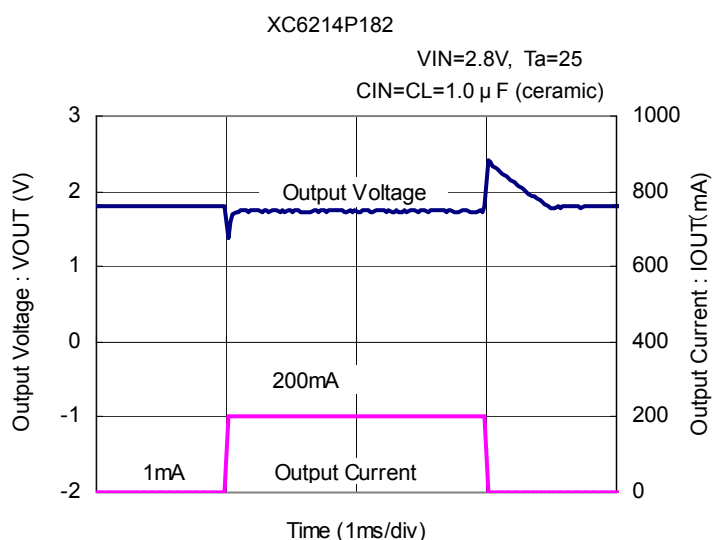
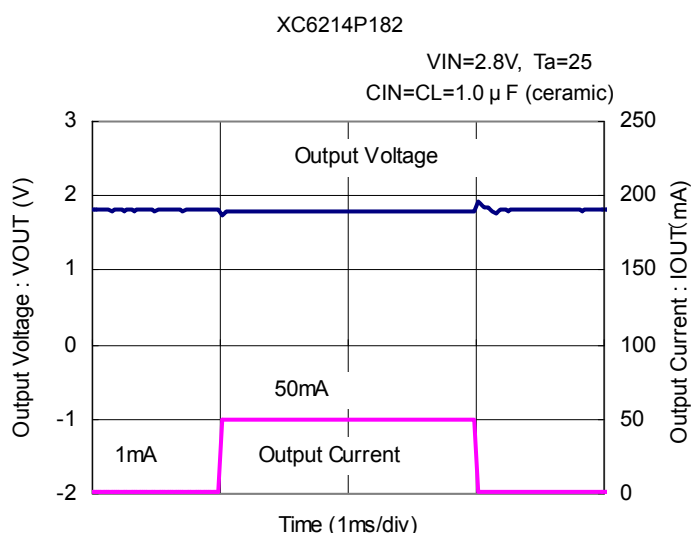
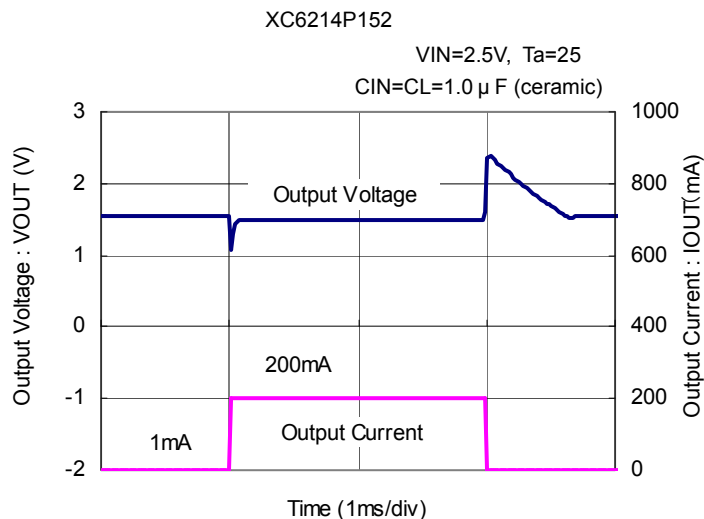
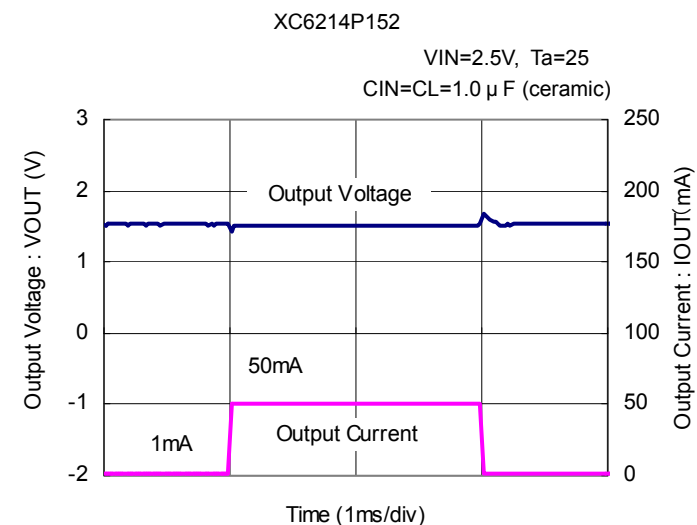

## TYPICAL PERFORMANCE CHARACTERISTICS (Continued)

### (8) Load Transient Response (Continued)

XC6214P332

VIN=4.3V, Ta=25  
CIN=CL=1.0 μ F (ceramic)

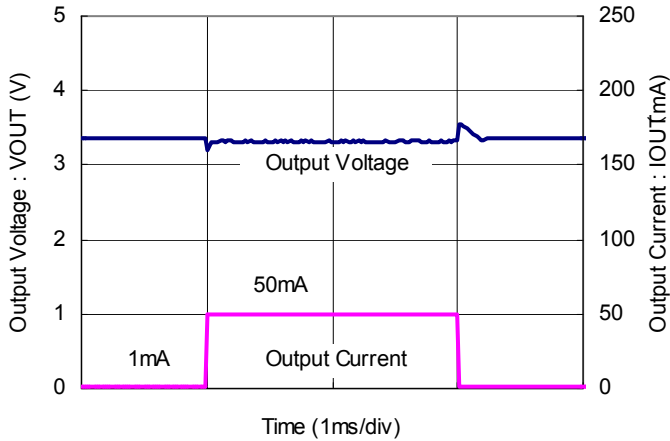

XC6214P332

VIN=4.3V, Ta=25  
CIN=CL=1.0 μ F (ceramic)

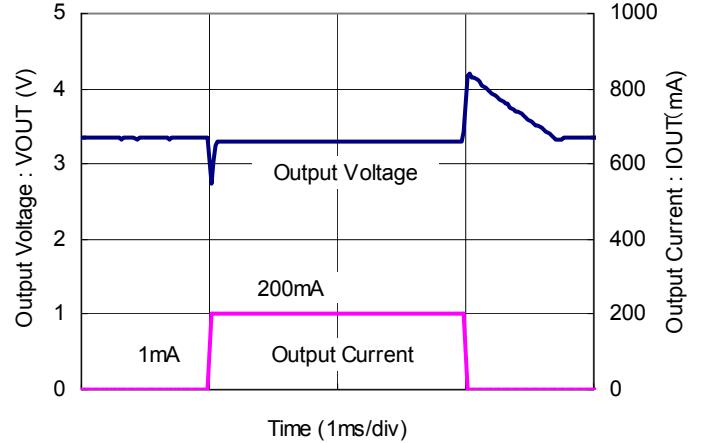

### (9) Ripple Rejection Rate

XC6214P122

VIN=2.2VDC+0.5p-pAC, IOU=50mA  
CL=1.0 μ F (ceramic)

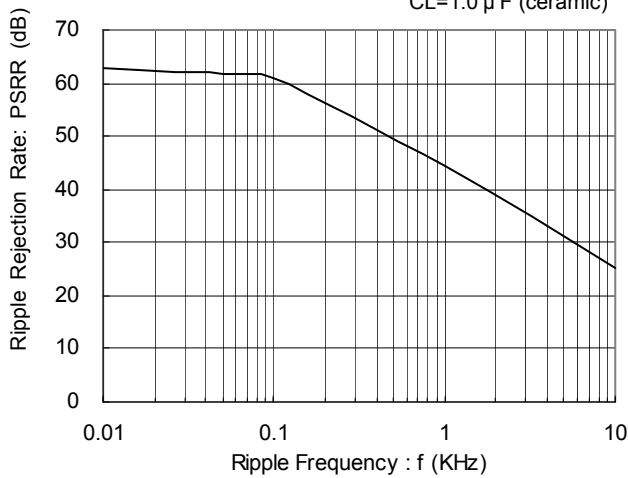

XC6214P122

VIN=2.2VDC+0.5p-pAC, IOU=200mA  
CL=1.0 μ F (ceramic)

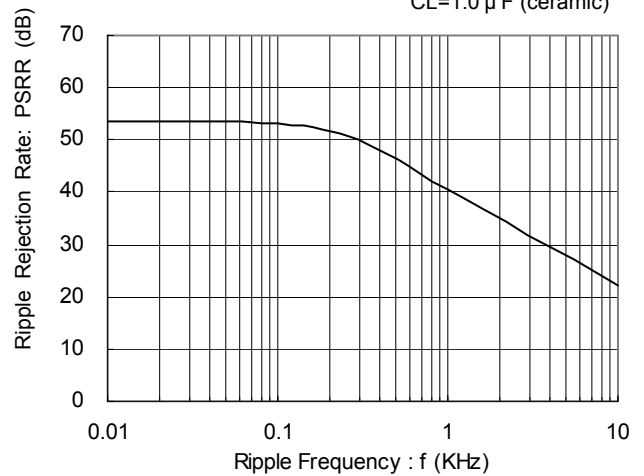

XC6214P152

VIN=2.5VDC+0.5p-pAC, IOU=50mA  
CL=1.0 μ F (ceramic)

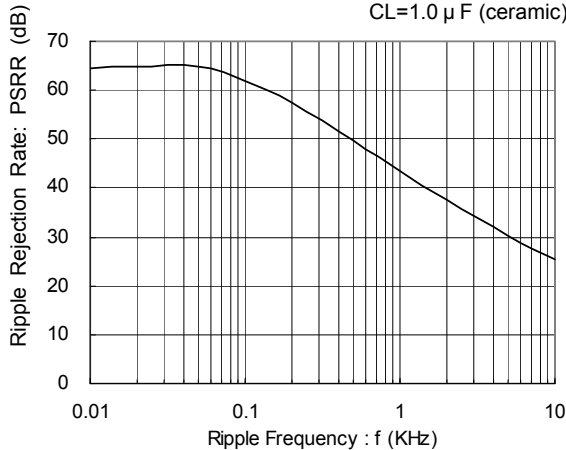

XC6214P152

VIN=2.5VDC+0.5p-pAC, IOU=200mA  
CL=1.0 μ F (ceramic)

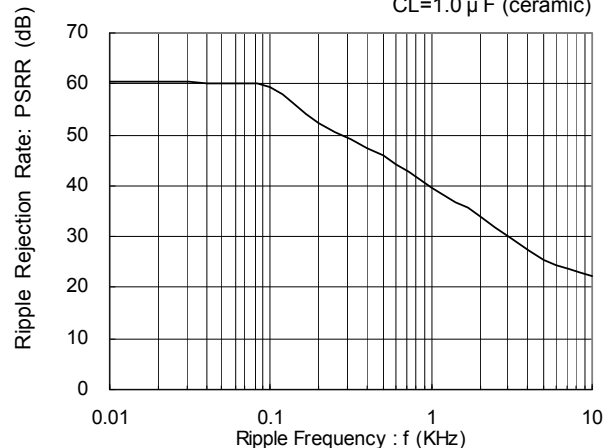

## TYPICAL PERFORMANCE CHARACTERISTICS (Continued)

### (9) Ripple Rejection Rate (Continued)

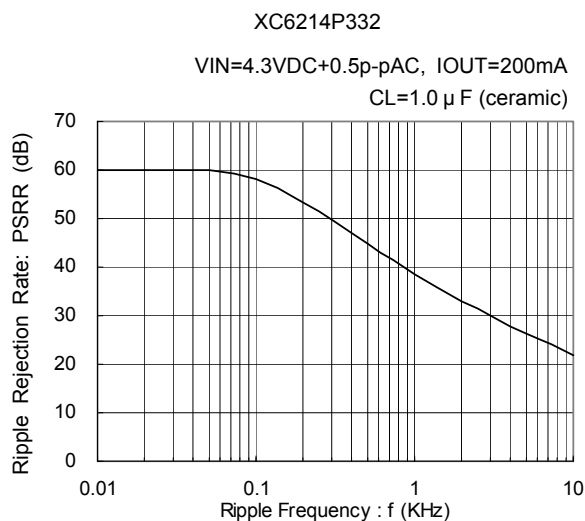
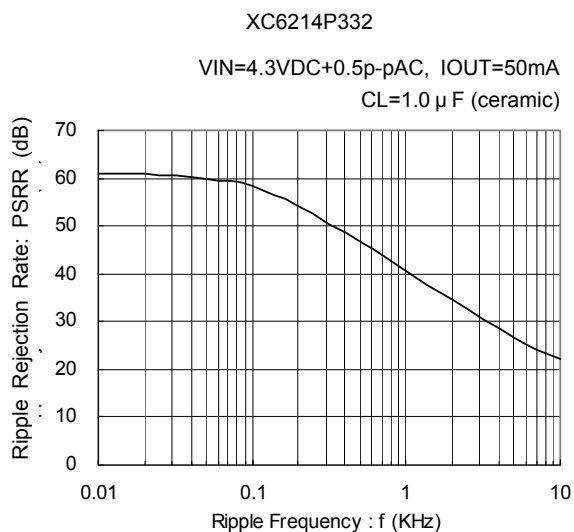
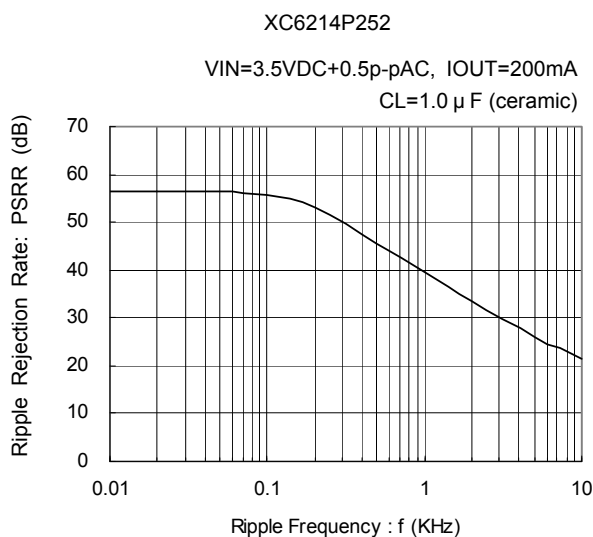
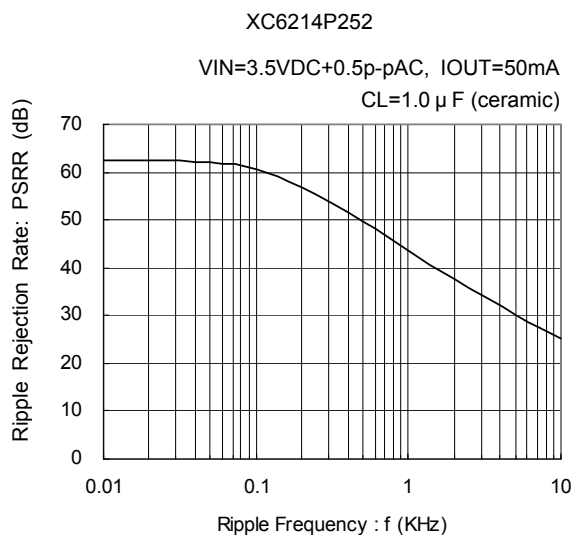
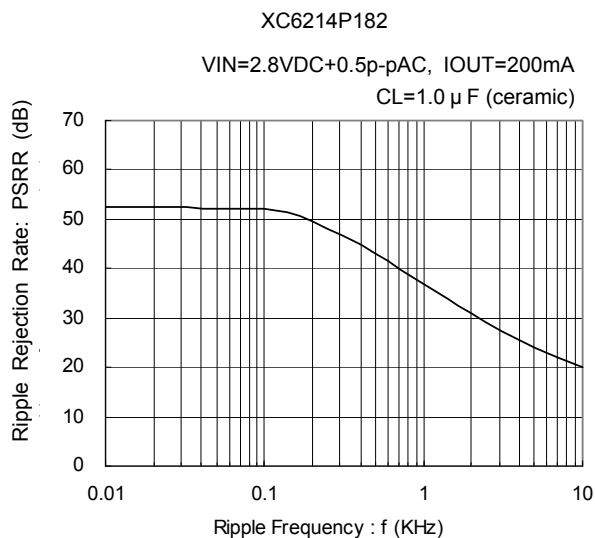
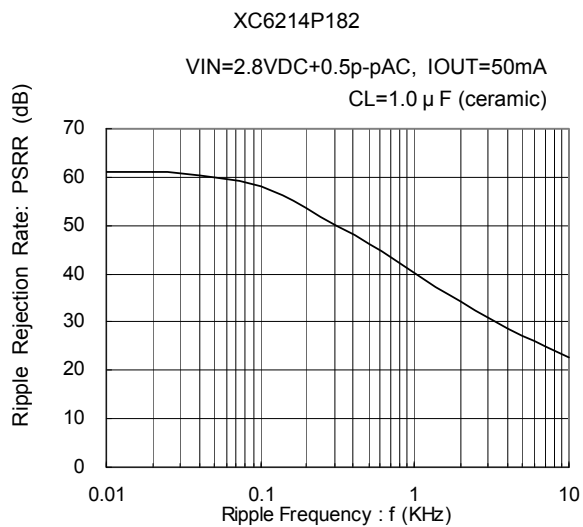

## PACKAGING INFORMATION

### SOT-89

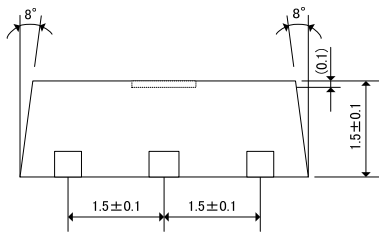
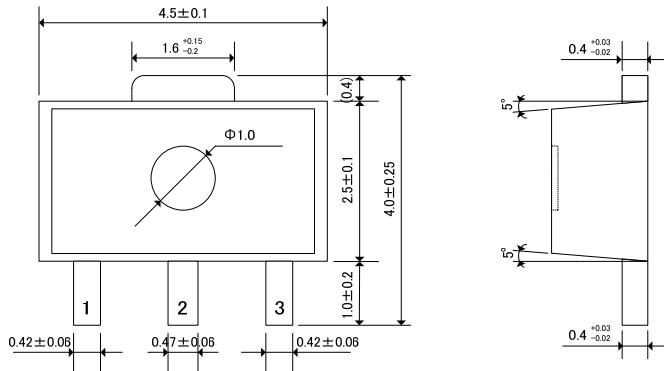

### TO-252

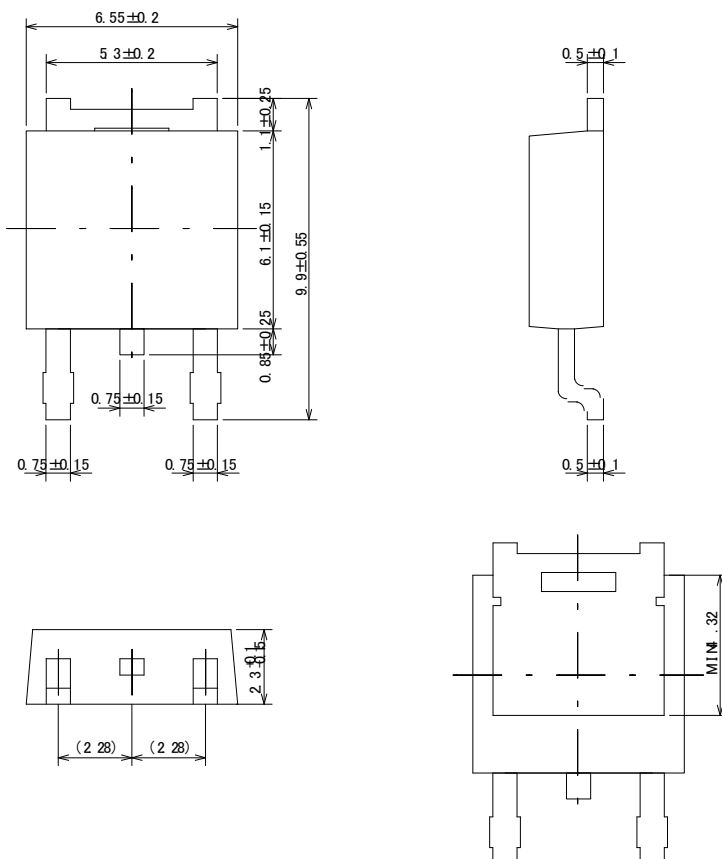

## MARKING RULE

SOT-89, TO-252

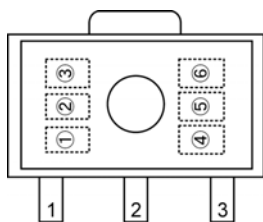

SOT - 89  
(TOP VIEW)

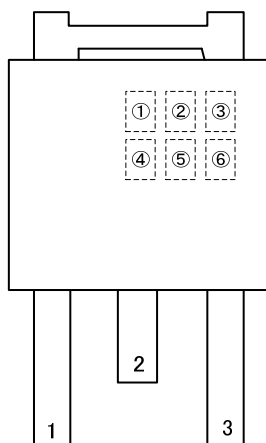

TO - 252  
(TOP VIEW)

Represents product series

MARK	PRODUCT SERIES
D	XC6214Pxx2xx

Represents output voltage range

MARK	VOLTAGE (V)	PRODUCT SERIES
P	1.2 ~ 3.0	XC6214Pxx2xx
R	3.1 ~ 5.0	XC6214Pxx2xx

Represents output voltage

MARK	VOLTAGE (V)		MARK	VOLTAGE (V)	
0	-	3.1	F	1.6	4.6
1	-	3.2	H	1.7	4.7
2	-	3.3	K	1.8	4.8
3	-	3.4	L	1.9	4.9
4	-	3.5	M	2.0	5.0
5	-	3.6	N	2.1	-
6	-	3.7	P	2.2	-
7	-	3.8	R	2.3	-
8	-	3.9	S	2.4	-
9	-	4.0	T	2.5	-
A	-	4.1	U	2.6	-
B	1.2	4.2	V	2.7	-
C	1.3	4.3	W	2.8	-
D	1.4	4.4	Y	2.9	-
E	1.5	4.5	Z	3.0	-

Represents the last digit of the production year (ex.)

MARK	PRODUCTION YEAR
6	2006
7	2007

Represents the production month

MARK	MONTH	MARK	MONTH	MARK	MONTH
A	January	E	May	J	September
B	February	F	June	K	October
C	March	G	July	L	November
D	April	H	August	M	December

Represents production lot number

0 to 9, A to Z repeated (G, I, J, O, Q, W excluded).

Note: No character inversion used.

1. The products and product specifications contained herein are subject to change without notice to improve performance characteristics. Consult us, or our representatives before use, to confirm that the information in this datasheet is up to date.
2. We assume no responsibility for any infringement of patents, patent rights, or other rights arising from the use of any information and circuitry in this datasheet.
3. Please ensure suitable shipping controls (including fail-safe designs and aging protection) are in force for equipment employing products listed in this datasheet.
4. The products in this datasheet are not developed, designed, or approved for use with such equipment whose failure or malfunction can be reasonably expected to directly endanger the life of, or cause significant injury to, the user.  
(e.g. Atomic energy; aerospace; transport; combustion and associated safety equipment thereof.)
5. Please use the products listed in this datasheet within the specified ranges.  
Should you wish to use the products under conditions exceeding the specifications, please consult us or our representatives.
6. We assume no responsibility for damage or loss due to abnormal use.
7. All rights reserved. No part of this datasheet may be copied or reproduced without the prior permission of TOREX SEMICONDUCTOR LTD.

**TOREX SEMICONDUCTOR LTD.**