

Adaptor Board datasheet

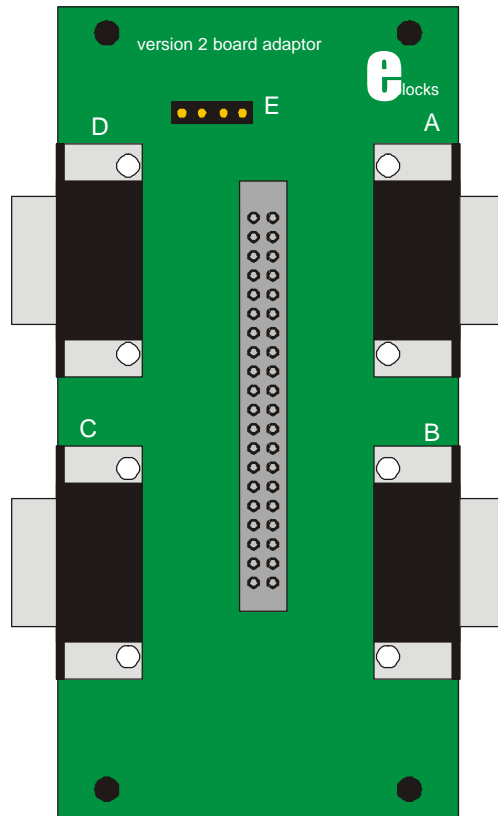
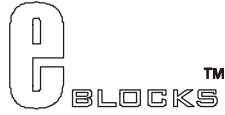

Contents

1. About this document
 2. General information
 3. Board Layout
 4. Getting Started
 5. Circuit description
- Appendix
- o Circuit Diagram

1 About this document

This document concerns the Matrix Adaptor Board code EB-009-00-1.

Trademarks and Copyright

PIC, PICmicro are registered trademarks of Arizona Microchip Inc.

E-blocks is a trademark of Matrix Multimedia Limited.

EB-009-00-1 and associates software and documentation are Copyright ©2004 Matrix Multimedia Limited.

Other sources of information

There are various other documents and sources that you may find useful:

Getting started with E-Blocks.pdf

This describes the E-blocks system and how it can be used to develop complete systems for learning electronics and for PICmicro programming.

PPP Help file

This describes the PPP software and its functionality. PPP software is used for transferring hex code to a PICmicro microcontroller.

Disclaimer

The information in this document is correct at the time of going to press. Matrix Multimedia reserves the right to change specifications from time to time.

Technical support

If you have any problems operating this product then please refer to the troubleshooting section of this document first. You will find the latest software updates, FAQs and other information on our web site:

www.matrixmultimedia.co.uk. If you still have problems please email us at:

support@matrixmultimedia.co.uk. When emailing please state the operating system, the version of PPP you are using.

2 General information

Description

This small circuit board can be connected to the version 2 PICmicro microcontroller Development board using a 40-way ribbon cable (HPBCAB). The E-Blocks adaptor will make four ports available on 9-way D-type sockets so that you can connect E-Blocks infrared, Rs232, keypad and other E-Block sub-systems to your development board. There is also access to port E via the header pin J6.

Features

- E-blocks compatible
- Low cost
- Compatible with most I/O ports in the E-Block range (up to 8 I/O lines via 9 way D-type connector)
- Ease to develop programming code using Flowcode icons.

3 Adaptor Board Layout

- 1) 9 Way D-type Socket – Port A
- 2) 9 Way D-type Socket – Port B
- 3) 9 Way D-type Socket – Port C
- 4) 9 Way D-type Socket – Port D
- 5) Header Pin – Port E
- 6) IDC Connector – Adaptor

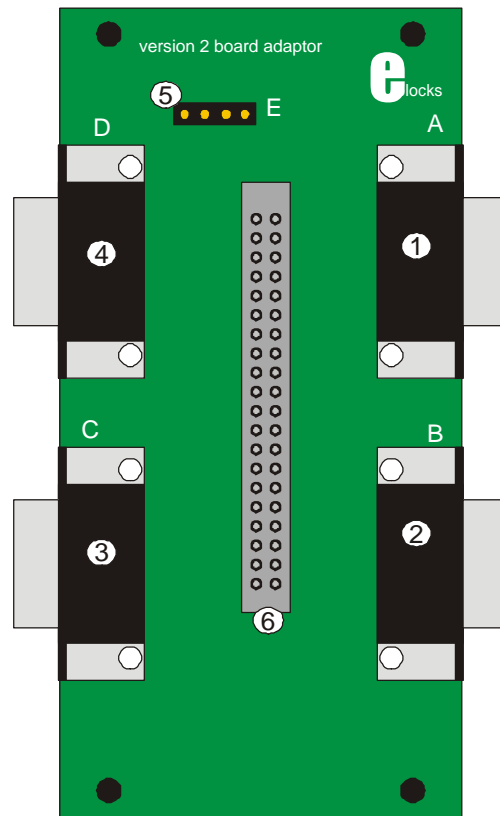

4 Getting Started

To use the Adaptor Board you must plug in a 40-Way IDC cable from the Version 2 PICmicro microcontroller development board to this board. Ensure that the IDC cable is connected correctly – pin 1 on PICmicro microcontroller development board should be connected to pin 1 of the Adaptor Board. Now you can use E-Block components controlled via the PICmicro microcontroller development board, by connecting the E-Block components to the correct ports using the 9-Way d-type connectors.

Testing the Adaptor Board

A user test for this board should not be necessary – if there is any doubt about the integrity of this board, a multimeter – in resistance mode – should be used to check that there is zero resistance between the relevant pins on the 40 way header and the appropriate pin on the D-type connector. The circuit diagram above should be used for this purpose.

5 Circuit description

This simple circuit takes the 40 pin IDC bus from version 2 PICmicro microcontroller development boards and splits this into 5 buses A to E. The PICmicro device in use on the development board determines the number of active lines on each bus and the datasheet of each device should be referred to for further information.

Port E only contains 3 bits and these are presented on a Moles type connector.

When using the adaptor board on buses A and B care should be taken to ensure that the circuit on the PICmicro development board side is taken into account – these lines have various circuits already on them – including switch circuits, LED circuits, 7 segment display circuits etc.

Matrix Multimedia Adaptor Board

Appendix 1 - Circuit Diagram

THIS SYSTEM INCLUDES:-

→ FEET

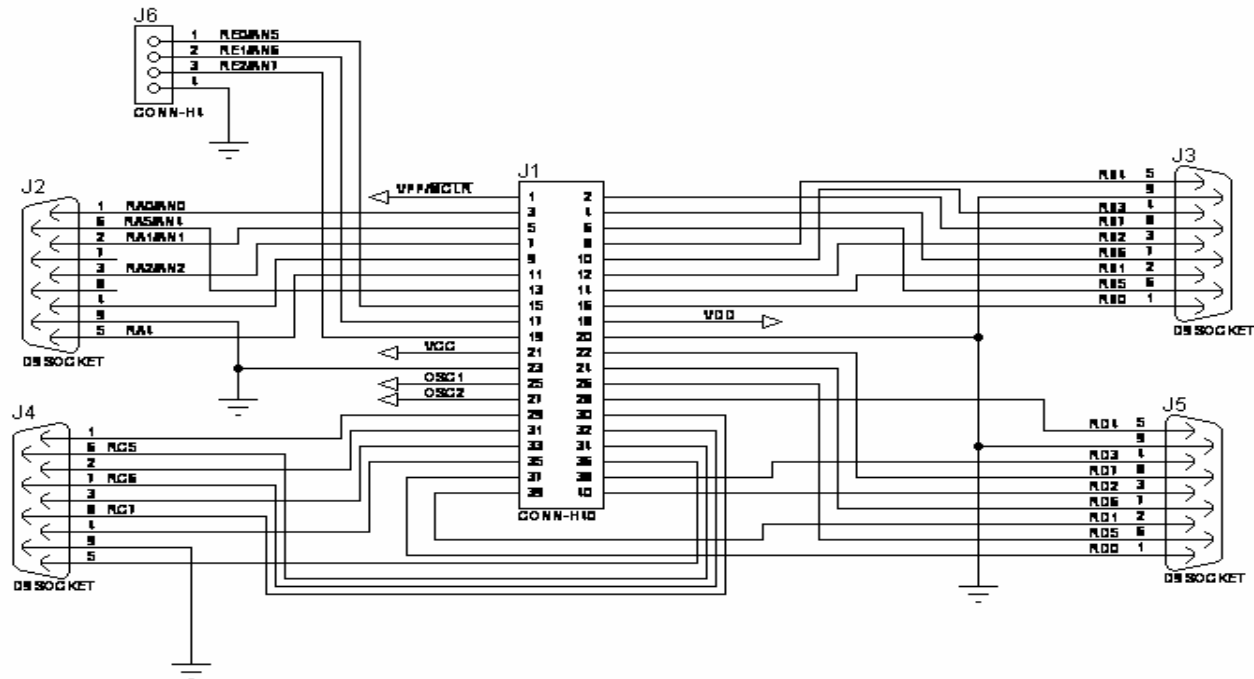

		MATRIX MULTIMEDIA LTD. www.matrixmultimedia.co.uk (c) Copyright 2004 Matrix Multimedia	
TITLE: E-BLOCKS ADAPTOR BRD EB-009-00-1		DATE: 26/03/04 PAGE: 1/1	
BY: Color Carr	REV: 1		