

74F189

64-Bit Random Access Memory with 3-STATE Outputs

General Description

The F189 is a high-speed 64-bit RAM organized as a 16-word by 4-bit array. Address inputs are buffered to minimize loading and are fully decoded on-chip. The outputs are 3-STATE and are in the high impedance state whenever the Chip Select (\overline{CS}) input is HIGH. The outputs are active only in the Read mode and the output data is the complement of the stored data.

Features

- 3-STATE outputs for data bus applications
- Buffered inputs minimize loading
- Address decoding on-chip
- Diode clamped inputs minimize ringing

Ordering Code:

Order Number	Package Number	Package Description
74F189SC	M16B	16-Lead Small Outline Integrated Circuit (SOIC), JEDEC MS-013, 0.300" Wide
74F189SJ	M16D	16-Lead Small Outline Package (SOP), EIAJ TYPE II, 5.3mm Wide
74F189PC	N16E	16-Lead Plastic Dual-In-Line Package (PDIP), JEDEC MS-001, 0.300" Wide

Devices also available in Tape and Reel. Specify by appending suffix "X" to the ordering code.

Logic Symbols

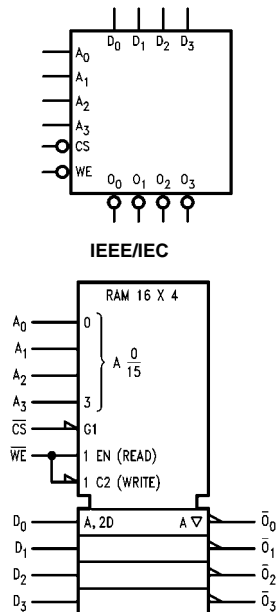

Connection Diagram

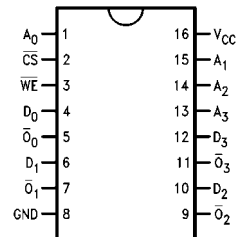

Unit Loading/Fan Out

Pin Names	Description	U.L. HIGH/LOW	Input I_H/I_{IL} Output I_{OH}/I_{OL}
A_0 - A_3	Address Inputs	1.0/1.0	20 μ A/-0.6 mA
\overline{CS}	Chip Select Input (Active LOW)	1.0/1.0	20 μ A/-1.2 mA
\overline{WE}	Write Enable Input (Active LOW)	1.0/1.0	20 μ A/-0.6 mA
D_0 - D_3	Data Inputs	1.0/1.0	20 μ A/-0.6 mA
\overline{O}_0 - \overline{O}_3	Inverted Data Outputs	150/40 (33.3)	-3.0 mA/24 mA (20 mA)

Function Table

Inputs		Operation	Condition of Outputs
\overline{CS}	\overline{WE}		
L	L	Write	High Impedance
L	H	Read	Complement of Stored Data
H	X	Inhibit	High Impedance

H = HIGH Voltage Level
 L = LOW Voltage Level
 X = Immaterial

Block Diagram

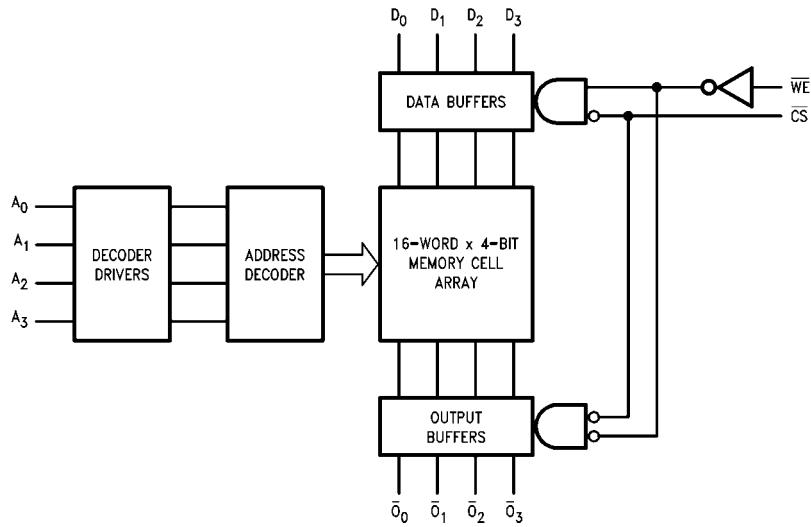

Absolute Maximum Ratings (Note 1)

Storage Temperature	-65°C to +150°C
Ambient Temperature under Bias	-55°C to +125°C
Junction Temperature under Bias	-55°C to +175°C
V _{CC} Pin Potential to Ground Pin	-0.5V to +7.0V
Input Voltage (Note 2)	-0.5V to +7.0V
Input Current (Note 2)	-30 mA to +5.0 mA
Voltage Applied to Output in HIGH State (with V _{CC} = 0V)	
Standard Output	-0.5V to V _{CC}
3-STATE Output	-0.5V to +5.5V
Current Applied to Output in LOW State (Max)	

Recommended Operating Conditions

Free Air Ambient Temperature	0°C to +70°C
Supply Voltage	+4.5V to +5.5V

Note 1: Absolute maximum ratings are values beyond which the device may be damaged or have its useful life impaired. Functional operation under these conditions is not implied.

Note 2: Either voltage limit or current limit is sufficient to protect inputs.

DC Electrical Characteristics

Symbol	Parameter	Min	Typ	Max	Units	V _{CC}	Conditions
V _{IH}	Input HIGH Voltage	2.0			V		Recognized as a HIGH Signal
V _{IL}	Input LOW Voltage			0.8	V		Recognized as a LOW Signal
V _{CD}	Input Clamp Diode Voltage			-1.2	V	Min	I _{IN} = -18 mA
V _{OH}	Output HIGH Voltage	10% V _{CC}	2.5		V	Min	I _{OH} = -1 mA
		10% V _{CC}	2.4	I _{OH} = -3 mA			
		5% V _{CC}	2.7	I _{OH} = -1 mA			
		5% V _{CC}	2.7	I _{OH} = -3 mA			
V _{OL}	Output LOW Voltage			0.5	V	Min	I _{OL} = 24 mA
I _{IH}	Input HIGH Current			5.0	μA	Max	V _{IN} = 2.7V
I _{BVI}	Input HIGH Current Breakdown Test			7.0	μA	Max	V _{IN} = 7.0V
I _{CEX}	Output HIGH Leakage Current			50	μA	Max	V _{OUT} = V _{CC}
V _{ID}	Input Leakage Test	4.75			V	0.0	I _{ID} = 1.9 μA All Other Pins Grounded
I _{OD}	Output Leakage Circuit Current			3.75	μA	0.0	V _{IOD} = 150 mV All Other Pins Grounded
I _{IL}	Input LOW Current			-0.6 -1.2	mA	Max	V _{IN} = 0.5V (except \overline{CS}) V _{IN} = 0.5V (\overline{CS})
I _{OZH}	Output Leakage Current			50	μA	Max	V _{OUT} = 2.7V
I _{OZL}	Output Leakage Current			-50	μA	Max	V _{OUT} = 0.5V
I _{OS}	Output Short-Circuit Current	-60	-150		mA	Max	V _{OUT} = 0V
I _{ZZ}	Bus Drainage Test			500	μA	0.0V	V _{OUT} = 5.25V
I _{CCZ}	Power Supply Current		37	55	mA	Max	V _O = HIGH Z

AC Electrical Characteristics									
Symbol	Parameter	$T_A = +25^\circ\text{C}$ $V_{CC} = +5.0\text{V}$ $C_L = 50\text{ pF}$			$T_A = -55^\circ\text{C to } +125^\circ\text{C}$ $V_{CC} = +5.0\text{V}$ $C_L = 50\text{ pF}$		$T_A = 0^\circ\text{C to } +70^\circ\text{C}$ $V_{CC} = +5.0\text{V}$ $C_L = 50\text{ pF}$		Units
		Min	Typ	Max	Min	Max	Min	Max	
t_{PLH}	Access Time, HIGH or LOW	10.0	18.5	26.0	9.0	32.0	10.0	27.0	ns
t_{PHL}	A_n to \overline{O}_n	8.0	13.5	19.0	8.0	23.0	8.0	20.0	
t_{PZH}	Access Time, HIGH or LOW	3.5	6.0	8.5	3.5	10.5	3.5	9.5	ns
t_{PZL}	\overline{CS} to \overline{O}_n	5.0	9.0	13.0	5.0	15.0	5.0	14.0	
t_{PHZ}	Disable Time, HIGH or LOW	2.0	4.0	6.0	2.0	8.0	2.0	7.0	ns
t_{PLZ}	\overline{CS} to \overline{O}_n	3.0	5.5	8.0	2.5	10.0	3.0	9.0	
t_{PZH}	Write Recovery Time,	6.5	15.0	28.0	6.5	37.5	6.5	29.0	ns
t_{PZL}	HIGH or LOW \overline{WE} to \overline{O}_n	6.5	11.0	15.5	6.5	17.5	6.5	16.5	
t_{PHZ}	Disable Time, HIGH or LOW	4.0	7.0	10.0	3.5	12.0	4.0	11.0	ns
t_{PLZ}	\overline{WE} to \overline{O}_n	5.0	9.0	13.0	5.0	15.0	5.0	14.0	
AC Operating Requirements									
Symbol	Parameter	$T_A = +25^\circ\text{C}$ $V_{CC} = +5.0\text{V}$		$T_A = -55^\circ\text{C to } +125^\circ\text{C}$ $V_{CC} = +5.0\text{V}$		$T_A = 0^\circ\text{C to } +70^\circ\text{C}$ $V_{CC} = +5.0\text{V}$		Units	
		Min	Max	Min	Max	Min	Max		
$t_S(H)$	Setup Time, HIGH or LOW	0		0		0		ns	
$t_S(L)$	A_n to \overline{WE}	0		0		0			
$t_H(H)$	Hold Time, HIGH or LOW	2.0		2.0		2.0		ns	
$t_H(L)$	A_n to \overline{WE}	2.0		2.0		2.0			
$t_S(H)$	Setup Time, HIGH or LOW	10.0		11.0		10.0		ns	
$t_S(L)$	D_n to \overline{WE}	10.0		11.0		10.0			
$t_H(H)$	Hold Time, HIGH or LOW	0		2.0		0		ns	
$t_H(L)$	D_n to \overline{WE}	0		2.0		0			
$t_S(L)$	Setup Time, LOW	0		0		0		ns	
	\overline{CS} to \overline{WE}								
$t_H(L)$	Hold Time, LOW	6.0		7.5		6.0		ns	
	\overline{CS} to \overline{WE}								
$t_W(L)$	\overline{WE} Pulse Width, LOW	6.0		15.0		6.0		ns	

Physical Dimensions inches (millimeters) unless otherwise noted

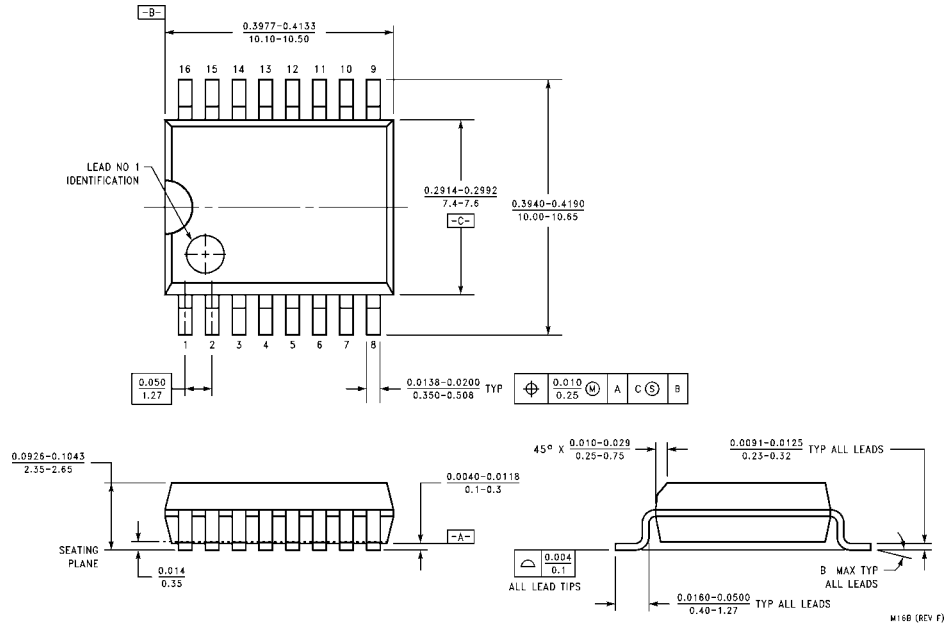

**16-Lead Small Outline Integrated Circuit (SOIC), JEDEC MS013, 0.300" Wide Body
Package Number M16B**

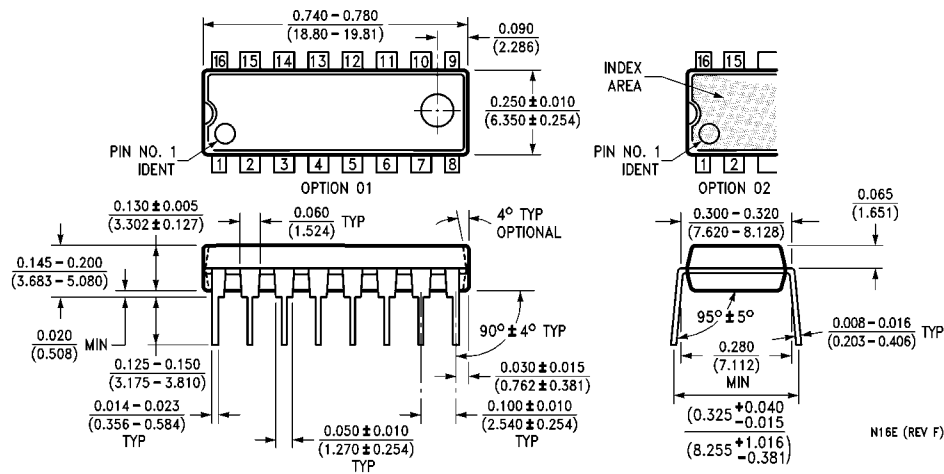

**16-Lead Plastic Dual-In-Line Package (PDIP), JEDEC MS-001, 0.300" Wide
Package Number N16E**

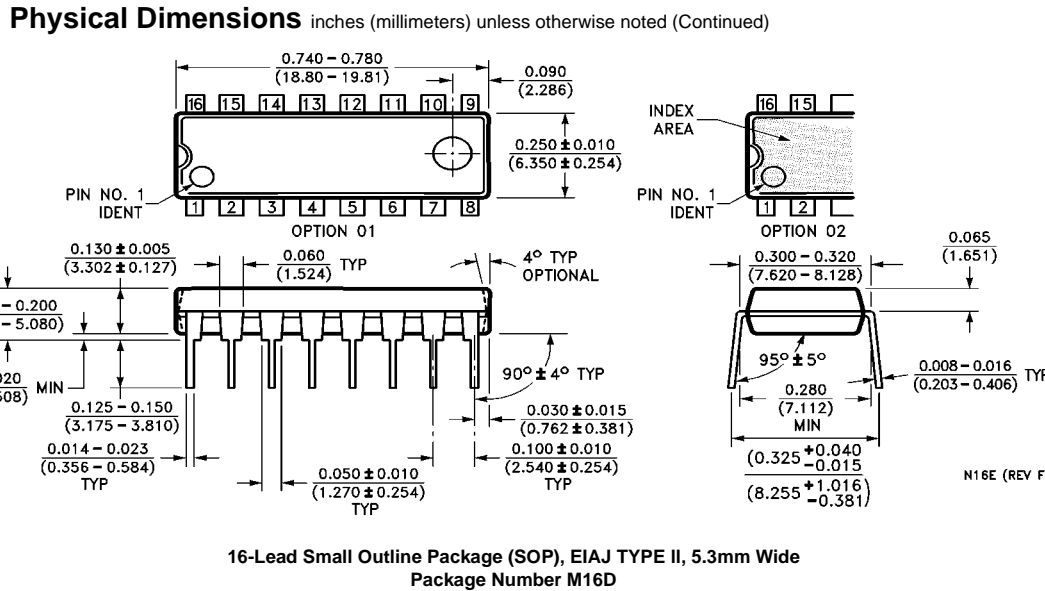

Fairchild does not assume any responsibility for use of any circuitry described, no circuit patent licenses are implied and Fairchild reserves the right at any time without notice to change said circuitry and specifications.

LIFE SUPPORT POLICY

FAIRCHILD'S PRODUCTS ARE NOT AUTHORIZED FOR USE AS CRITICAL COMPONENTS IN LIFE SUPPORT DEVICES OR SYSTEMS WITHOUT THE EXPRESS WRITTEN APPROVAL OF THE PRESIDENT OF FAIRCHILD SEMICONDUCTOR CORPORATION. As used herein:

1. Life support devices or systems are devices or systems which, (a) are intended for surgical implant into the body, or (b) support or sustain life, and (c) whose failure to perform when properly used in accordance with instructions for use provided in the labeling, can be reasonably expected to result in a significant injury to the user.
2. A critical component in any component of a life support device or system whose failure to perform can be reasonably expected to cause the failure of the life support device or system, or to affect its safety or effectiveness.

www.fairchildsemi.com