















Multi Purpose Die Cast

Features:

- Rugged Aluminium.
- 4 sides PCB guides.
- Stand offs.
- Zink plated screws for tapped holes.
- Neoprene rubber gasket.
- Easy to machine.
- BS colour choice.

5000 Series

Version Code				Dimensions (mm)			PDF	DWG
Nylon Coated	Hammer Tone	Black	White	D/L	W	H		
5001/11-NC	5001/11-PAT	5001/11-BK	5001/11-WH	50	50	31		
5002/12-NC	5002/12-PAT	5002/12-BK	5002/12-WH	101	50	24.5		
5003/13-NC	5003/13-PAT	5003/13-BK	5003/13-WH	112	62	30.5		
5004/14-NC	5004/14-PAT	5004/14-BK	5004/14-WH	120	65.5	39.5		
5007/17-NC	5007/17-PAT	5007/17-BK	5007/17-WH	121	95	61		
5005/15-NC	5005/15-PAT	5005/15-BK	5005/15-WH	152	82	50		
5006/16-NAT	5006/16-PAT	5006/16-BK	5006/16-WH	191.5	111.5	60.5		

OVERALL ASSEMBLY DIMENSIONS:

EXTERNAL - 152 x 82 x 49.75

INTERNAL - 149.4 x 78.4 x 45.5

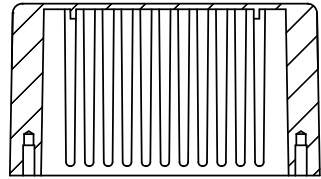

SECTION B-B

M3 CSK SCREW

LID

BASE

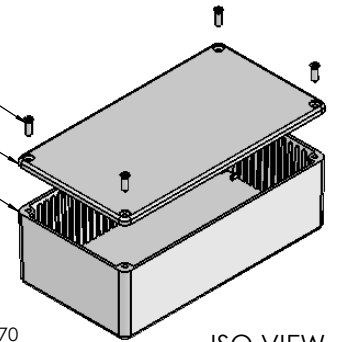

ISO VIEW
1:4

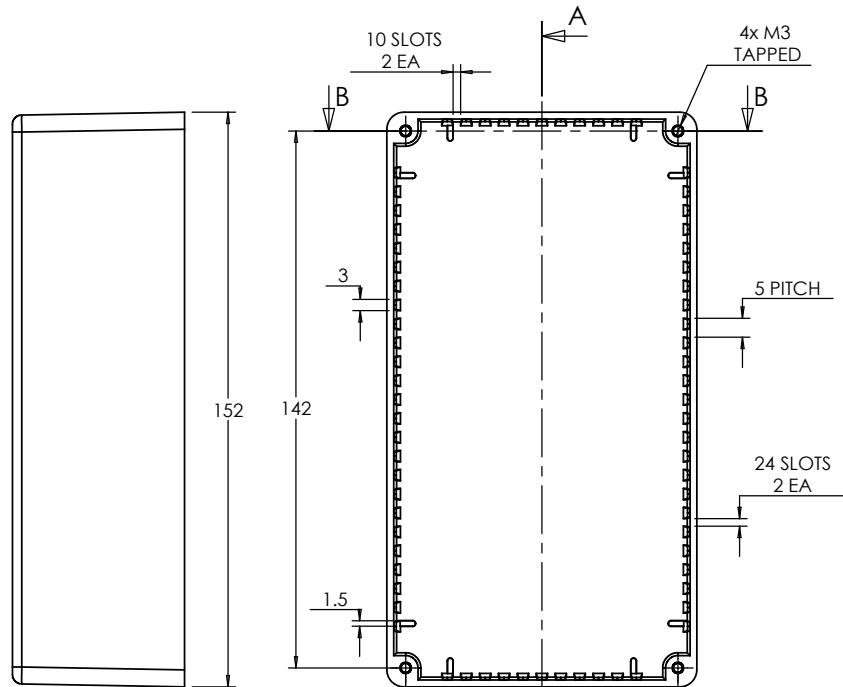
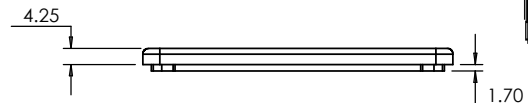

BASE

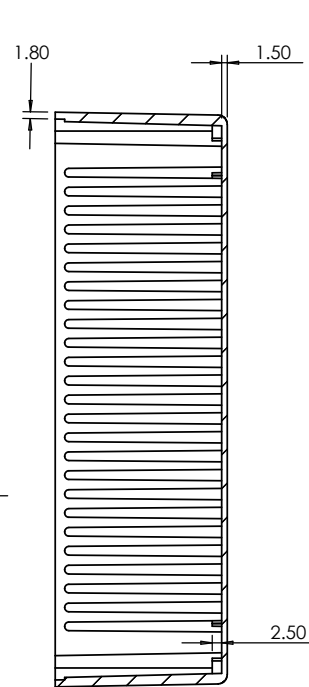

SECTION A-A

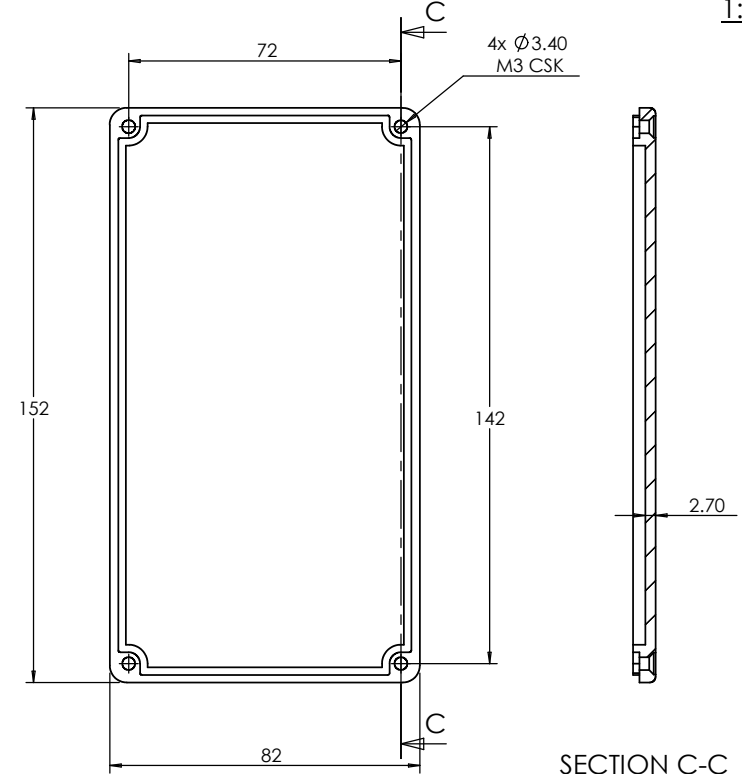

SECTION C-C

LID

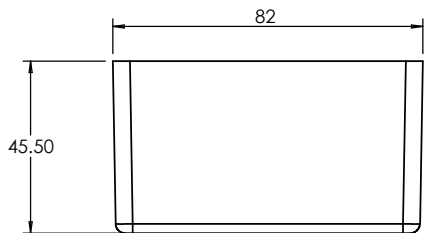

		UNLESS OTHERWISE SPECIFIED: DIMENSIONS ARE IN MILLIMETERS		DO NOT SCALE DRAWING	REVISION: 0
		FINISH: SMOOTH		TITLE: ASSEMBLY DRG FOR 5005/15	
JAMES CARTER RD, MILDENHALL, SUFFOLK. IP28 7DE TEL: 01638 716101 FAX: 01638 716554 EMAIL: SALES@BOSS-ENCLOSURES.CO.UK WEB: www.BOSS-ENCLOSURES.CO.UK		MATERIAL: DIE-CAST ALUMINIUM		DWG NO. 5005,15	A4
DRAWN	S.HARDINGE	SIGNED	SJH	DATE	07/12/05
CHK'D	-	-	-	-	-
PROJECTION:		SCALE: 1:2		SHEET 1 OF 1	