

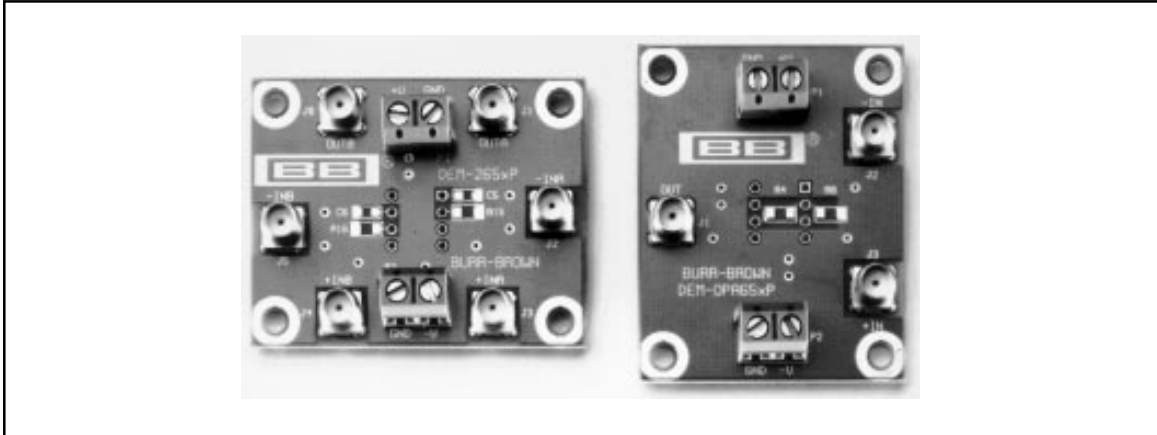

DEM-OPA65x DEM-OPA265x EVALUATION FIXTURES



FEATURES

- BOARDS FOR SINGLE AND DUAL OP AMPS
- SOIC AND DIP VERSIONS
- SURFACE MOUNT COMPONENTS FOR OPTIMUM PERFORMANCE
- SMA INPUT AND OUTPUT JACKS FOR MAXIMUM FREQUENCY RESPONSE
- UNIVERSAL POWER SUPPLY CONNECTION

DESCRIPTION

The DEM-OPA65x AND DEM-OPA265x evaluation fixtures are pre-assembled printed circuit boards designed to provide an optimized environment when evaluating the wideband operational amplifiers of the OPA65x series. The DEM-OPA65x is used for the single op amps, where the DEM-OPA265x is designed for dual op amps. A variety of different op amps can be evaluated with the same board. For example the voltage-feedback op amp OPA650/OPA651 or the current-feedback op amp OPA658. Similarly for the duals, the OPA2650 or the OPA2658 will fit on the DEM-OPA265x demonstration board. Since the boards are universal, the actual operational amplifier is not included with the evaluation board. Boards are available for both package types, the DIP and the SOIC package.

APPLICATIONS

- EASY EVALUATION OF CFA AND VFA OP AMPS
- EASY EVALUATION OF SINGLE AND DUAL OP AMPS
- EVALUATE HIGH-FREQUENCY, TWO-LAYER PCB LAYOUT

These demonstration boards have surface-mount resistors and ceramic bypass capacitors soldered on the board. A collection of gain setting resistors is included with the board. The feedback resistor is placed directly between the input and the output pins. This is necessary to achieve the maximum bandwidth. The power supply bypass capacitors consist of a tantalum and a ceramic chip capacitor pair on each of the power supplies. They are placed directly at the pins to maintain low harmonic distortion. For more detailed information on the operational amplifiers, refer to the individual datasheets.

The demoboard have been designed to support a variety of different circuit configurations. Also included are resistors for termination and isolation of load capacitance. Slight degradation of the ac-performance is the tradeoff. However, the number of required components depends on the selected configuration.

International Airport Industrial Park • Mailing Address: PO Box 11400 • Tucson, AZ 85734 • Street Address: 6730 S. Tucson Blvd. • Tucson, AZ 85706
Tel: (520) 746-1111 • Twx: 910-952-1111 • Cable: BBRCORP • Telex: 066-6491 • FAX: (520) 889-1510 • Immediate Product Info: (800) 548-6132

ORDERING INFORMATION

PART NUMBER	PACKAGE	CIRCUIT CONFIGURATION
DEM-OPA65xP	DIP	Single Op Amp
DEM-OPA65xU	SOIC	Single Op Amp
DEM-OPA265xP	DIP	Dual Op Amp
DEM-OPA265xU	SOIC	Dual Op Amp

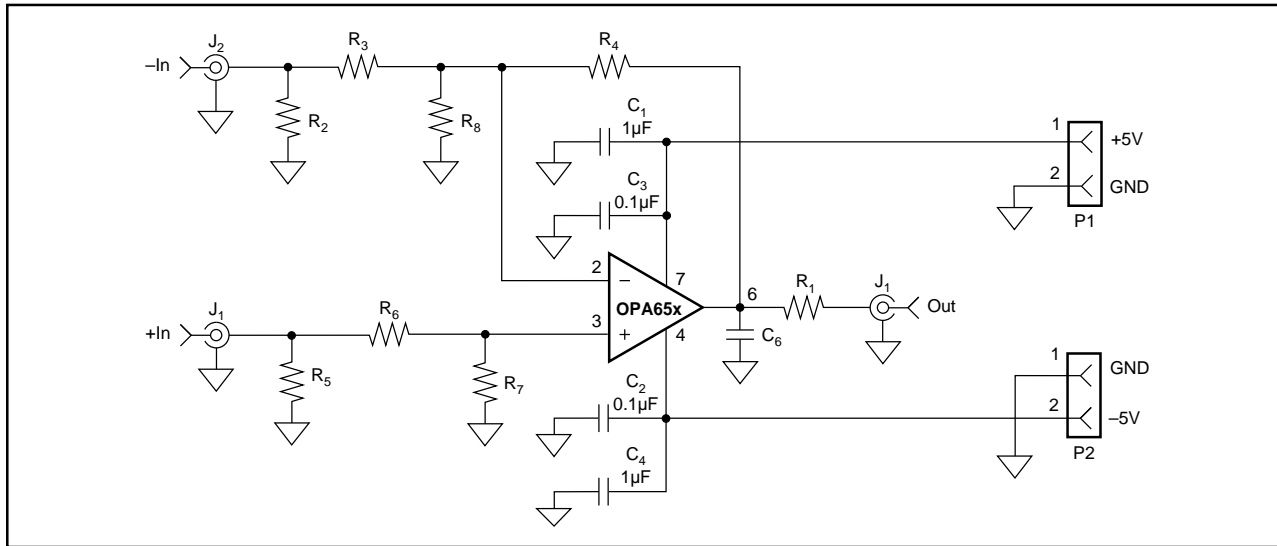

FIGURE 1. Circuit Diagram of the DEM-OPA65x.

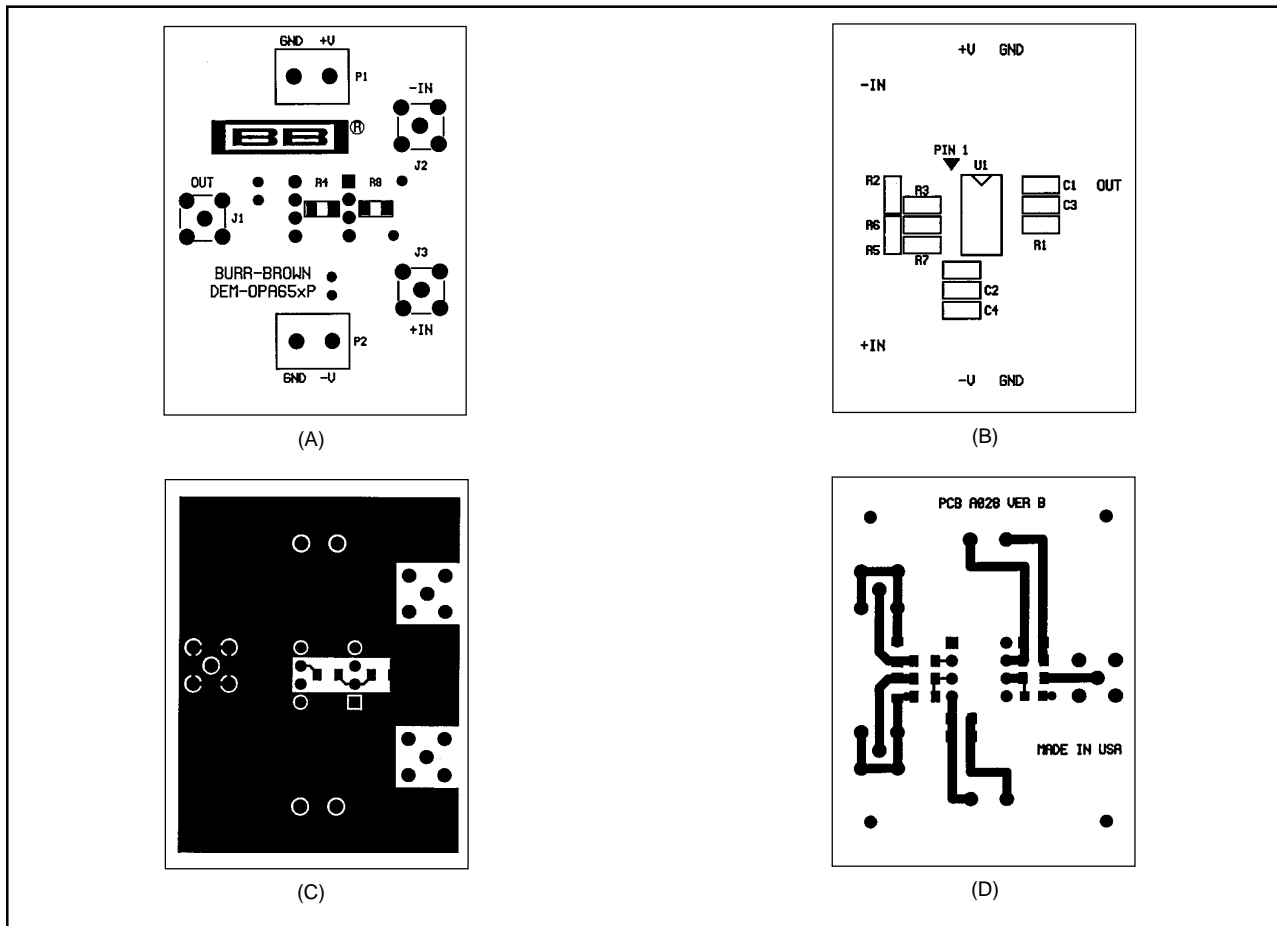

FIGURE 2. DEM-OPA65xP, (A) Silkscreen/Bottom, (B) Silkscreen/Top, (C) Solder Side, (D) Component Side.

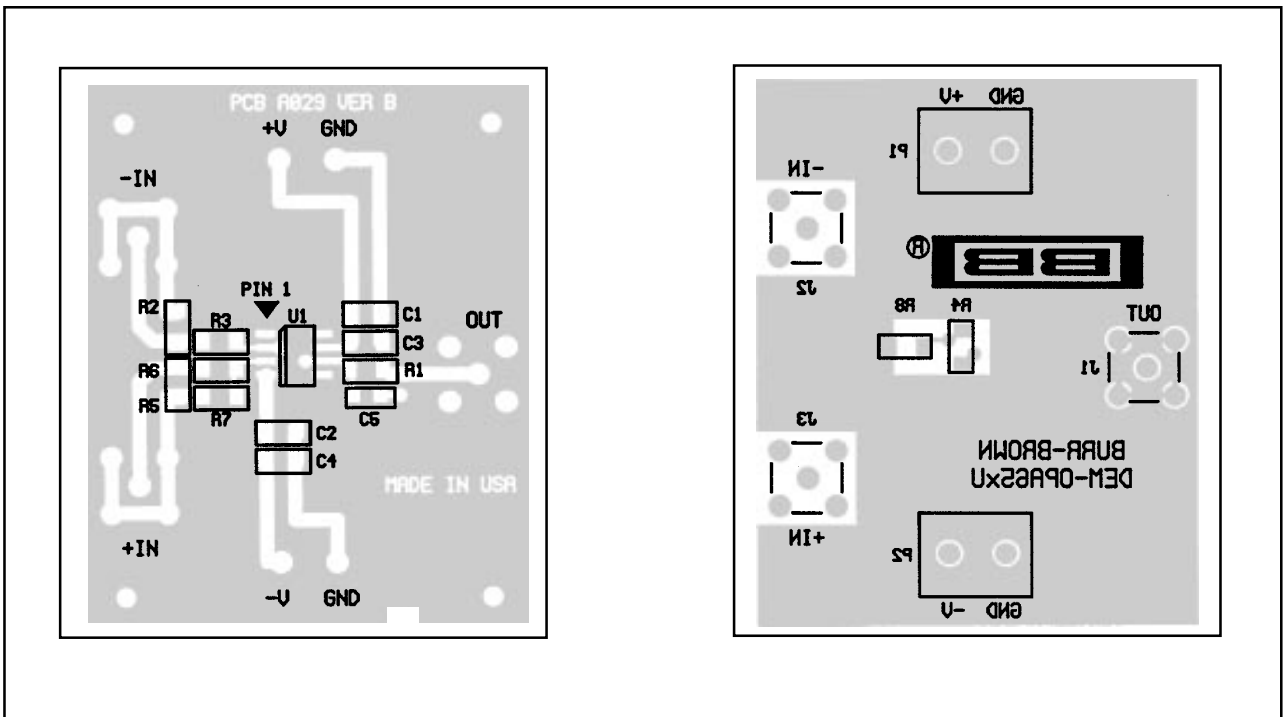

FIGURE 3. DEM-OPA65xU, Component Side, Solder Side and Silkscreen.

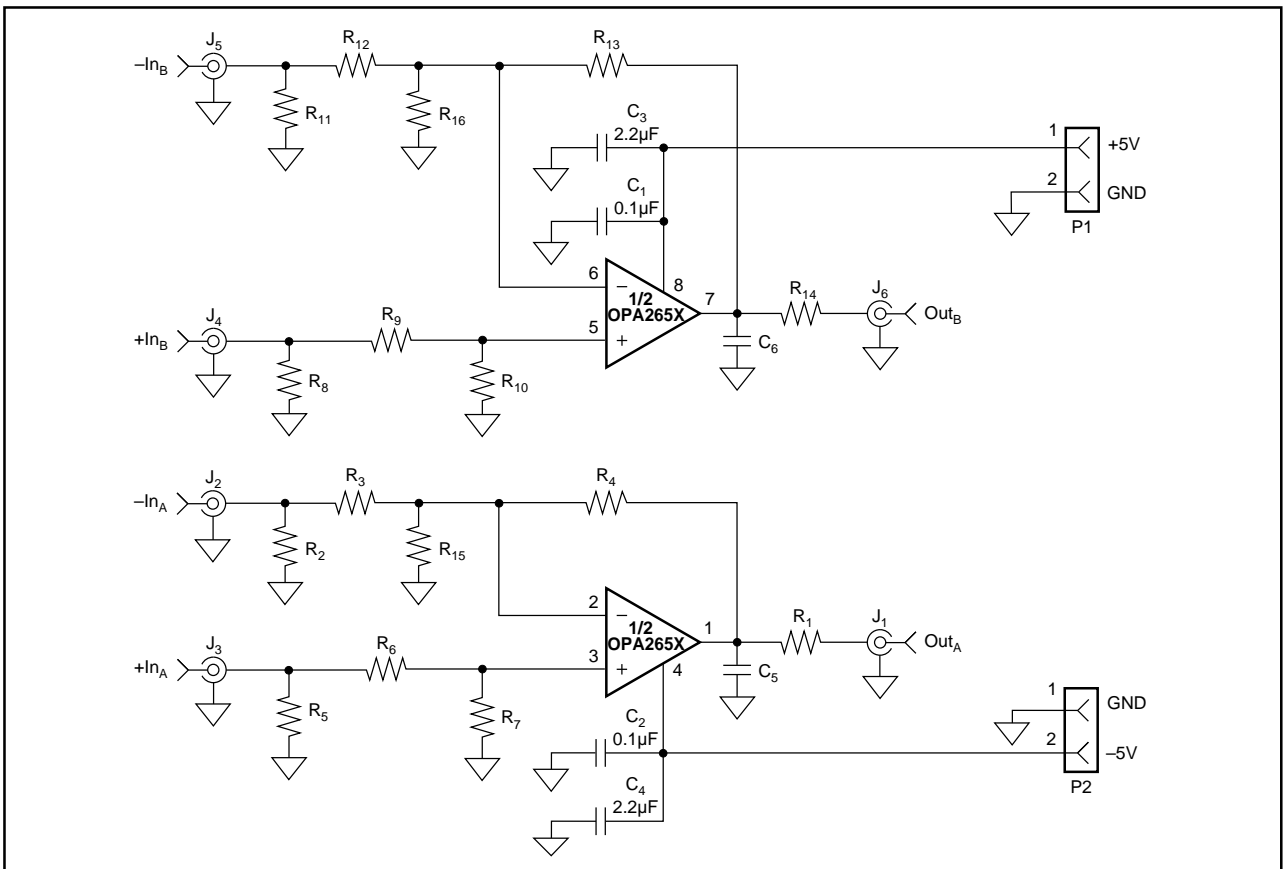

FIGURE 4. Circuit Diagram DEM-OPA265x.

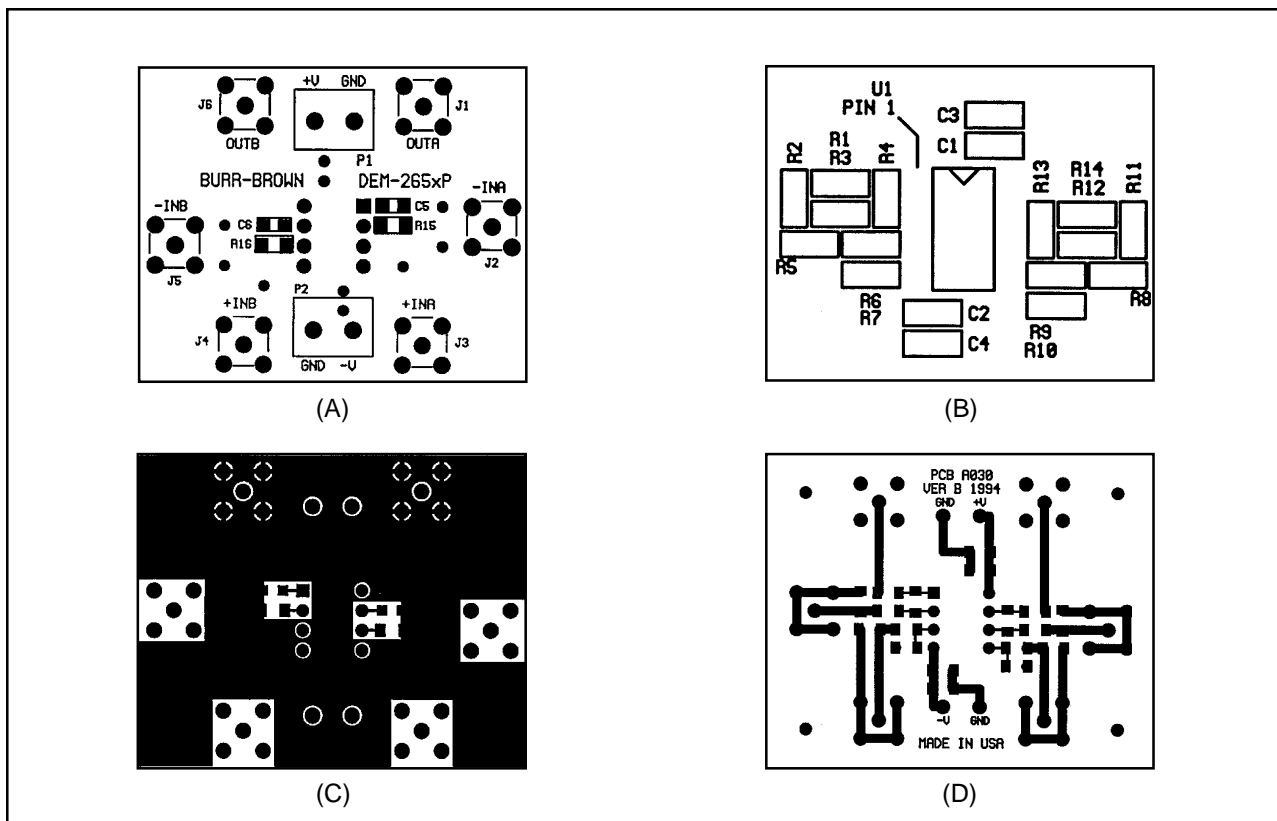

FIGURE 5. DEM-OPA265xP: (A) Silkscreen/Bottom, (B) Silkscreen/Top, (C) Solder Side, (D) Component Side.

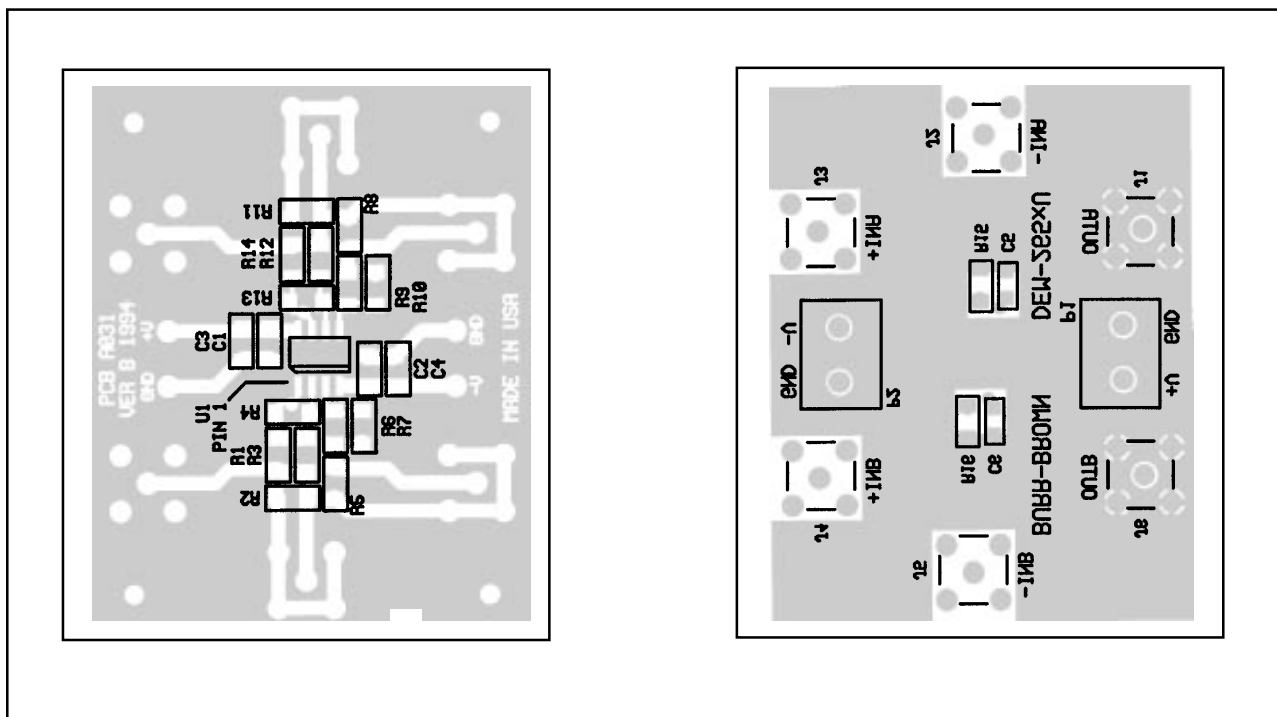

FIGURE 6. DEM-OPA265xU, Component Side, Solder Side and Silkscreen.