

## 2.0-channel high-efficiency digital audio system

### Features

- Wide voltage supply range
  - 5 V to 26 V (operating range)
  - 30 V (absolute maximum rating)
- 2 channels of ternary PWM (stereo mode) (2 x 20 W into 8  $\Omega$  at 18 V)
- 2.0 channels of 24-bit FFX 100 dB SNR and dynamic range
- Selectable 32 to 192 kHz input sample rates
- I<sup>2</sup>C control with selectable device address
- Digital gain/attenuation +48 dB to -80 dB with 0.5 dB/step resolution
- Soft volume update with programmable ratio
- Individual channel and master gain/attenuation
- Individual channel and master soft/hard mute
- Automatic zero-detect mute
- Automatic invalid input-detect mute
- 2-channel I<sup>2</sup>S input data interface
- Advanced AM interference frequency switching and noise suppression modes
- Selectable high- or low-bandwidth noise-shaping topologies
- Variable max power correction for lower full-power THD
- Selectable clock input ratio

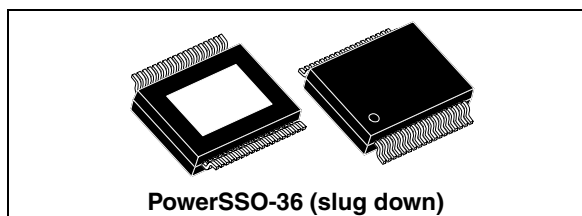

- 96 kHz internal processing sample rate, 24 to 28-bit precision
- Thermal overload and short-circuit protection embedded
- Video apps: 576 x Fs input mode supported
- Fully compatible with STA335BW (on the common registers).

**Table 1. Device summary**

Order code	Package	Packaging
STA335W	PowerSSO-36 slug down	Tube
STA335W13TR	PowerSSO-36 slug down	Tape and reel





# 1 Description FFX

The STA335W is an integrated solution of digital audio processing, digital amplifier control, and FFX -power output stage, thereby creating a high-power single-chip FFX solution comprising high-quality, high-efficiency, all digital amplification.

STA335W is based on FFX (Full Flexible Amplification) processor.

The STA335W is part of the Sound Terminal™ family that provides full digital audio streaming to the speaker, offering cost effectiveness, low power dissipation and sound enrichment.

The STA335W power section consists of two full-bridges. The two channels can provide up to 2 x 20 W of power.

The serial audio data input interface accepts all possible formats, including the popular I<sup>2</sup>S format. Two channels of FFX processing are provided. This high-quality conversion from PCM audio to FFX PWM switching waveform provides over 100 dB SNR and dynamic range.

## 1.1 Block diagram

Figure 1. Block diagram

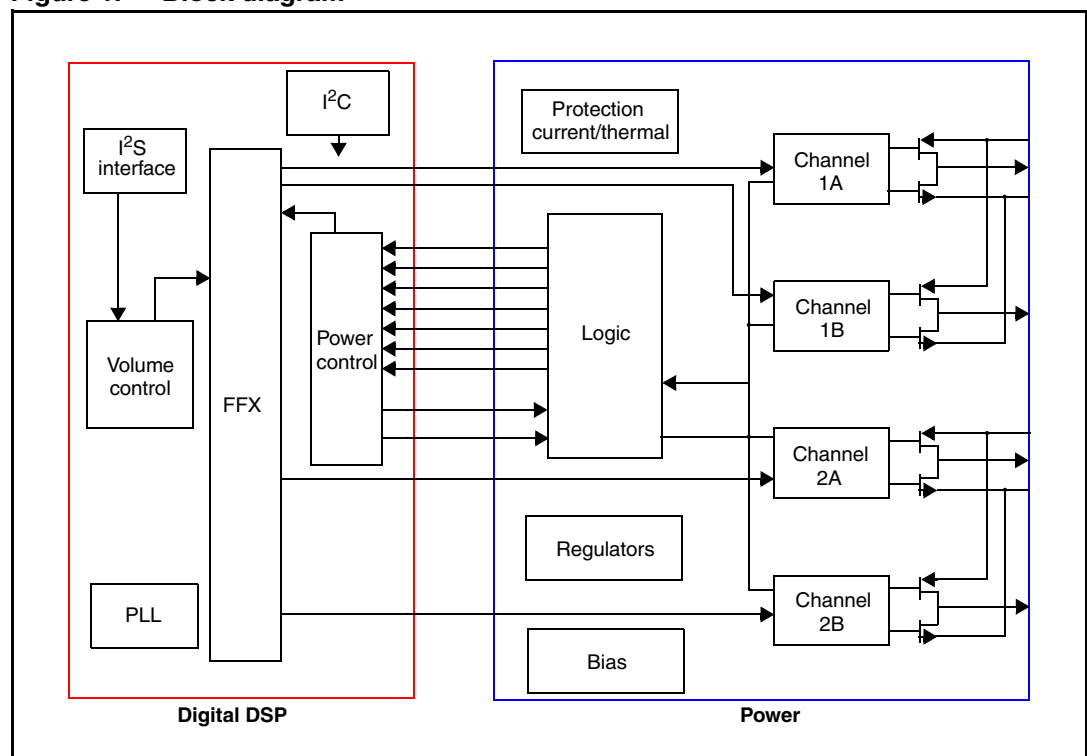

## 2 Pin connections

### 2.1 Connection diagram

Figure 2. Pin connection PowerSSO-36 (Top view)

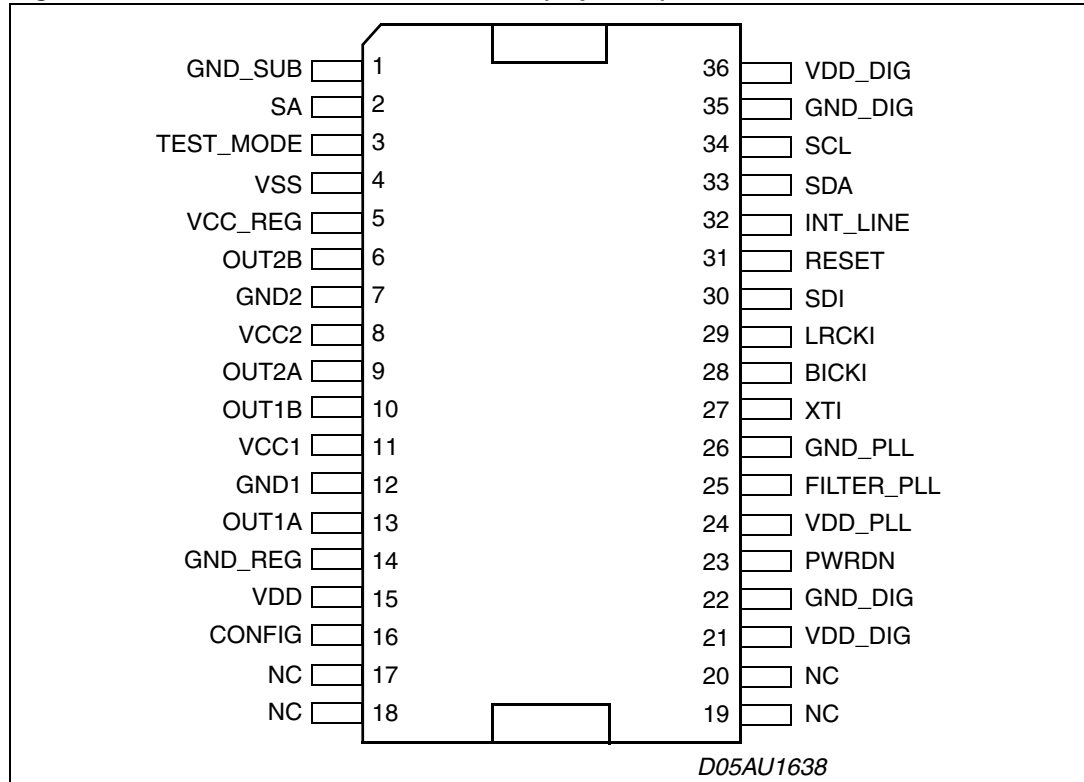

### 2.2 Pin description

Table 2. Pin description

Pin	Type	Name	Description
1	GND	GND_SUB	Substrate ground
2	I	SA	I <sup>2</sup> C select address (pull-down)
3	I	TEST_MODE	This pin must be connected to ground (pull-down)
4	I/O	VSS	Internal reference at Vcc-3.3 V
5	I/O	VCC_REG	Internal Vcc reference
6	O	OUT2B	Output half bridge 2B
7	GND	GND2	Power negative supply
8	Power	VCC2	Power positive supply
9	O	OUT2A	Output half bridge 2A
10	O	OUT1B	Output half bridge 1B

Table 2. Pin description (continued)

Pin	Type	Name	Description
11	Power	VCC1	Power positive supply
12	GND	GND1	Power negative supply
13	O	OUT1A	Output half bridge 1A
14	GND	GND_REG	Internal ground reference
15	Power	VDD	Internal 3.3 V reference voltage
16	I	CONFIG	Paralleled mode command
17	O	N.C.	Not to be connected
18	O	N.C.	Not to be connected
19	O	N.C.	Not to be connected
20	I/O	N.C.	Not to be connected
21	Power	VDD_DIG	Digital supply voltage
22	GND	GND_DIG	Digital ground
23	I	PWRDN	Power down (pull-up)
24	Power	VDD_PLL	Positive supply for PLL
25	I	FILTER_PLL	Connection to PLL filter
26	GND	GND_PLL	Negative supply for PLL
27	I	XTI	PLL input clock
28	I	BICKI	I <sup>2</sup> S serial clock
29	I	LRCKI	I <sup>2</sup> S left/right clock
30	I	SDI	I <sup>2</sup> S serial data channels 1 and 2
31	I	RESET	Reset (pull-up)
32	O	INT_LINE	Fault interrupt
33	I/O	SDA	I <sup>2</sup> C serial data
34	I	SCL	I <sup>2</sup> C serial clock
35	GND	GND_DIG	Digital ground
36	Power	VDD_DIG	Digital supply voltage

## 3 Electrical specifications

### 3.1 Absolute maximum ratings

**Table 3. Absolute maximum ratings**

Symbol	Parameter	Min	Typ	Max	Unit
V <sub>CC</sub>	Power supply voltage (VCCxA, VCCxB)	-0.3		30	V
VDD_DIG	Digital supply voltage	-0.3		4	V
VDD_PLL	PLL supply voltage	-0.3		4	
T <sub>op</sub>	Operating junction temperature	-20		150	°C
T <sub>stg</sub>	Storage temperature	-40		150	°C

**Warning:** Stresses beyond those listed in [Table 3](#) may cause permanent damage to the device. These are stress ratings only, and functional operation of the device at these or any other conditions beyond those indicated under “Recommended operating conditions” are not implied. Exposure to absolute-maximum-rated conditions for extended periods may affect device reliability. In the real application, power supplies with nominal values rated within the recommended operating conditions, may experience some rising beyond the maximum operating conditions for a short time when no or very low current is sunk (amplifier in mute state). In this case the reliability of the device is guaranteed, provided that the absolute maximum ratings are not exceeded.

### 3.2 Thermal data

**Table 4. Thermal data**

	Parameter	Min	Typ	Max	Unit
R <sub>th j-case</sub>	Thermal resistance junction-case (thermal pad)			1.5	°C/W
T <sub>th-sdj</sub>	Thermal shut-down junction temperature		150		°C
T <sub>th-w</sub>	Thermal warning temperature		130		°C
T <sub>th-sdh</sub>	Thermal shut-down hysteresis		20		°C
R <sub>th j-amb</sub>	Thermal resistance junction-ambient <sup>(1)</sup>				

1. See [Section 7: Package thermal characteristics on page 39](#) for details.

### 3.3 Recommended operating conditions

**Table 5. Recommended operating condition**

Symbol	Parameter	Min	Typ	Max	Unit
$V_{CC}$	Power supply voltage (VCCxA, VCCxB)	5		26	V
VDD_DIG	Digital supply voltage	2.7	3.3	3.6	V
VDD_PLL	PLL supply voltage	2.7	3.3	3.6	V
$T_{amb}$	Ambient temperature	-20		70	°C

### 3.4 Electrical specifications for the digital section

**Table 6. Electrical specifications - digital section**

Symbol	Parameter	Conditions	Min	Typ	Max	Unit
$I_{il}$	Low level input current without pull-up/down device	$V_i = 0$ V		1	10	$\mu$ A
$I_{ih}$	High level input current without pull-up/down device	$V_i = VDD\_DIG = 3.6$ V		1	10	$\mu$ A
$V_{il}$	Low level input voltage				0.2 * VDD_DIG	V
$V_{ih}$	High level input voltage		0.8 * VDD_DIG			V
$V_{ol}$	Low level output voltage	$I_{ol}=2$ mA			0.4 * VDD_DIG	V
$V_{oh}$	High level output voltage	$I_{oh}=2$ mA	0.8 * VDD_DIG			V
$I_{pu}$	Pull-up/down current		25	66	125	$\mu$ A
$R_{pu}$	Equivalent pull-up/down resistance			50		k $\Omega$



### 3.5 Electrical specifications for the power section

The specifications given in this section are valid for the operating conditions:  $V_{CC} = 18\text{ V}$ ,  $f = 1\text{ kHz}$ ,  $f_{sw} = 384\text{ kHz}$ ,  $T_{amb} = 25^\circ\text{ C}$  and  $R_L = 8\ \Omega$ , unless otherwise specified.

**Table 7. Electrical specifications - power section**

Symbol	Parameter	Conditions	Min	Typ	Max	Unit
Po	Output power BTL	THD = 1%		16		W
		THD = 10%		20		
R <sub>dsON</sub>	Power Pchannel/Nchannel MOSFET (total bridge)	I <sub>d</sub> = 1.5 A		180	250	mΩ
gP	Power Pchannel RdsON matching	I <sub>d</sub> = 1.5 A	95			%
gN	Power Nchannel RdsON matching	I <sub>d</sub> = 1.5 A	95			%
Idss	Power Pchannel/Nchannel leakage	V <sub>CC</sub> = 20 V			10	μA
I <sub>LDT</sub>	Low current dead time (static)	Resistive load <sup>(1)</sup>		8	15	ns
I <sub>HDT</sub>	High current dead time (dynamic)	I <sub>load</sub> = 1.5 A <sup>(1)</sup>		15	30	ns
t <sub>r</sub>	Rise time	Resistive load <sup>(1)</sup>		10	18	ns
t <sub>f</sub>	Fall time	Resistive load <sup>(1)</sup>		10	18	ns
V <sub>cc</sub>	Supply voltage operating voltage		5		26	V
I <sub>vcc</sub>	Supply current from Vcc in power down	PWRDN = 0		0.1	1	mA
	Supply current from Vcc in operation	PCM Input signal = -60 dBfs, Switching frequency = 384 kHz, No LC filters		52	60	mA
I <sub>vdd</sub>	Supply current FFX processing (reference only)	Internal clock = 49.152 MHz		55	70	mA
I <sub>lim</sub>	Overcurrent limit	<sup>(2)</sup>	3.0	3.8		A
I <sub>sc</sub>	Short circuit protection	Hi-Z output	4.0	4.2		A
UVL	Under voltage protection			3.5	4.3	V
t <sub>min</sub>	Output minimum pulse width	No load	20	30	60	ns
DR	Dynamic range			100		dB
SNR	Signal to noise ratio, ternary mode	A-Weighted		100		dB
	Signal to noise ratio binary mode			90		dB
PSSR	Power supply rejection ratio	FFX stereo mode, <5 kHz V <sub>RIPPLE</sub> = 1 V RMS Audio input = dither only		80		dB
THD+N	Total harmonic distortion + noise	FFX stereo mode, Po = 1 W f = 1 kHz		0.2		%

Table 7. Electrical specifications - power section (continued)

Symbol	Parameter	Conditions	Min	Typ	Max	Unit
$X_{TALK}$	Crosstalk	FFX stereo mode, <5 kHz One channel driven at 1 W Other channel measured		80		dB
$\eta$	Peak efficiency, FFX mode	$P_o = 2 \times 20 \text{ W}$ into $8 \Omega$		90		%
	Peak efficiency, binary modes	$P_o = 2 \times 9 \text{ W}$ into $4 \Omega$ + $1 \times 20 \text{ W}$ into $8 \Omega$		87		

1. Refer to [Figure 5: Test circuit 1](#).
2. Limit current if the register (OCRb par 6.1.3.3) overcurrent warning detect adjustment bypass is enabled. When disabled refer to the  $I_{sc}$ .

### 3.6 Power on/off sequence

Figure 3. Power-on sequence

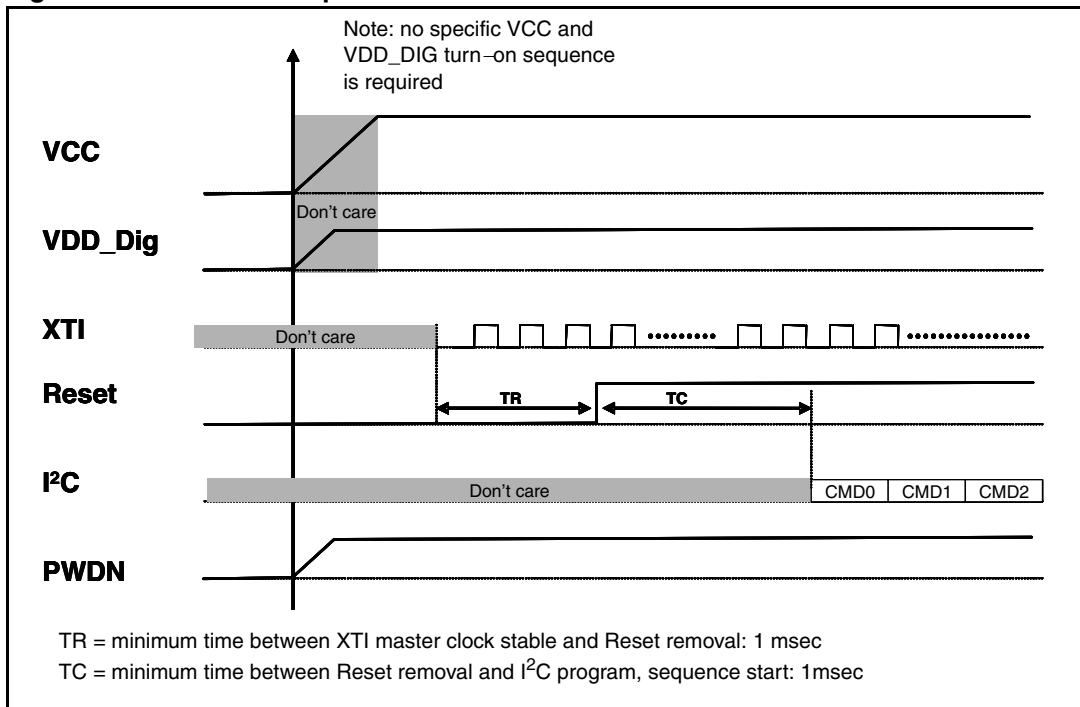

Note: clock stable means:  $f_{max} - f_{min} < 1 \text{ MHz}$

Note: see [Chapter 5.2.3: Serial data first bit](#), for additional info.

Figure 4. Power-off sequence for pop-free turn-off

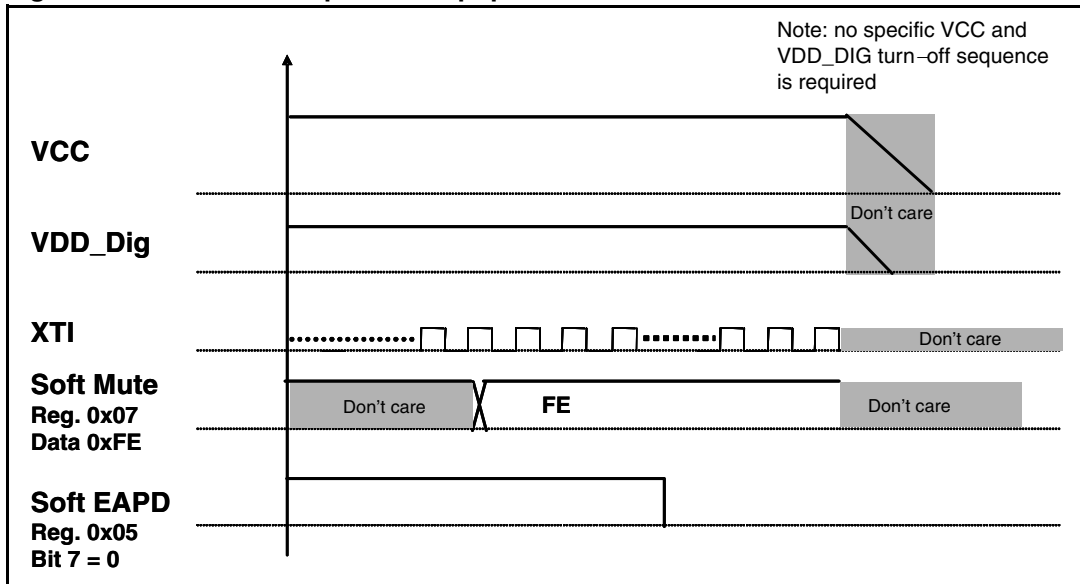

### 3.7 Testing

#### 3.7.1 Functional pin definition

Table 8. Functional pin definition

Pin name	Number	Logic value	IC status
PWRDN	23	0	Low consumption
		1	Normal operation
TWARN	20	0	A temperature warning is indicated by the external power stage
		1	Normal operation
EAPD	19	0	Low consumption for power stage All internal regulators are switched off
		1	Normal operation

Figure 5. Test circuit 1

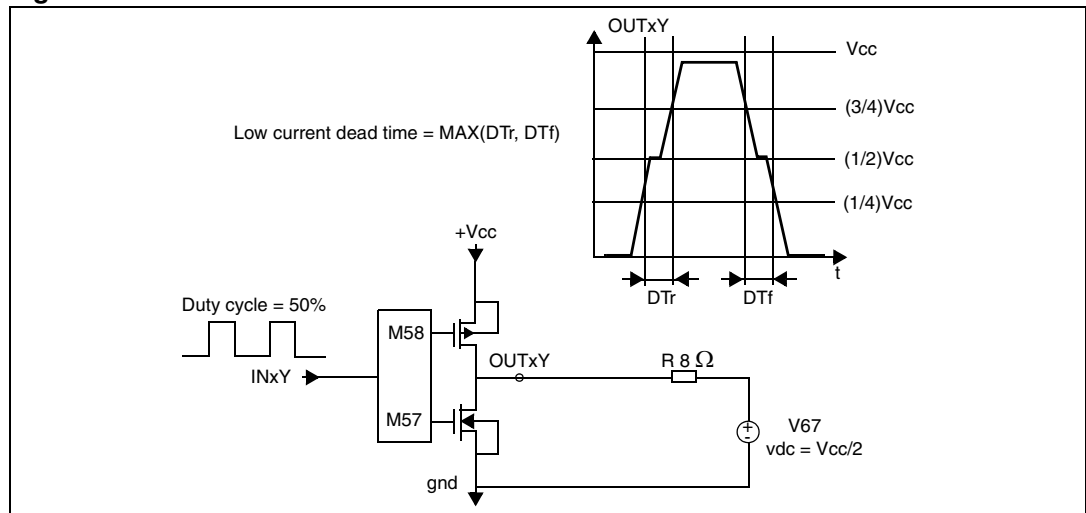
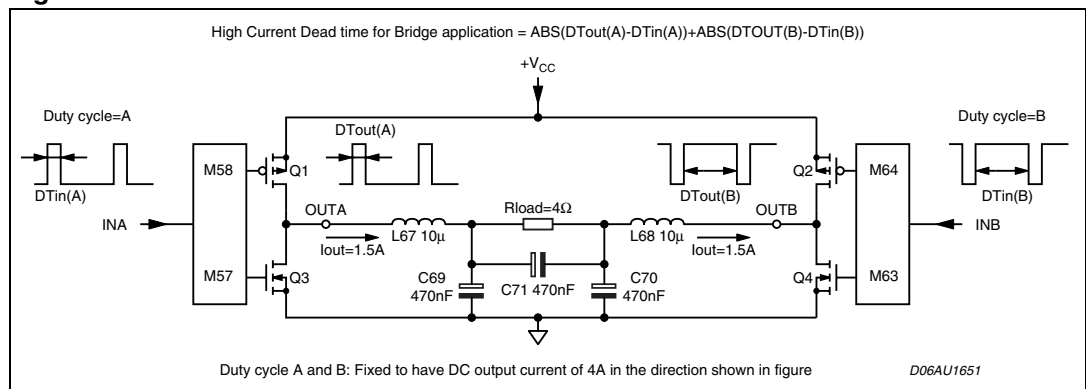

Figure 6. Test circuit 2



## 4 I<sup>2</sup>C bus specification

The STA335W supports the I<sup>2</sup>C protocol via the input ports SCL and SDA\_IN (master to slave) and the output port SDA\_OUT (slave to master). This protocol defines any device that sends data on to the bus as a transmitter and any device that reads the data as a receiver. The device that controls the data transfer is known as the master and the other as the slave. The master always starts the transfer and provides the serial clock for synchronization. STA335W is always a slave device in all of its communications. It supports up to 400 kb/s rate (fast-mode bit rate). STA335W I<sup>2</sup>C is a slave only interface.

### 4.1 Communication protocol

#### 4.1.1 Data transition or change

Data changes on the SDA line must only occur when the SCL clock is low. SDA transition while the clock is high is used to identify a START or STOP condition.

#### 4.1.2 Start condition

START is identified by a high to low transition of the data bus SDA signal while the clock signal SCL is stable in the high state. A START condition must precede any command for data transfer.

#### 4.1.3 Stop condition

STOP is identified by low to high transition of the data bus SDA signal while the clock signal SCL is stable in the high state. A STOP condition terminates communication between STA335W and the bus master.

#### 4.1.4 Data input

During the data input the STA335W samples the SDA signal on the rising edge of clock SCL. For correct device operation the SDA signal must be stable during the rising edge of the clock and the data can change only when the SCL line is low.

### 4.2 Device addressing

To start communication between the master and the STA335W, the master must initiate with a start condition. Following this, the master sends onto the SDA line 8-bits (MSB first) corresponding to the device select address and read or write mode.

The seven most significant bits are the device address identifiers, corresponding to the I<sup>2</sup>C bus definition. In the STA335W the I<sup>2</sup>C interface has two device addresses depending on the SA port configuration, 0x38 when SA = 0, and 0x3A when SA = 1.

The eighth bit (LSB) identifies read or write operation RW, this bit is set to 1 in read mode and to 0 for write mode. After a START condition the STA335W identifies on the bus the device address and if a match is found, it acknowledges the identification on SDA bus during the 9th bit time. The byte following the device identification byte is the internal space address.

## 4.3 Write operation

Following the START condition the master sends a device select code with the RW bit set to 0. The STA335W acknowledges this and the writes for the byte of internal address. After receiving the internal byte address the STA335W again responds with an acknowledgement.

### 4.3.1 Byte write

In the byte write mode the master sends one data byte, this is acknowledged by the STA335W. The master then terminates the transfer by generating a STOP condition.

### 4.3.2 Multi-byte write

The multi-byte write modes can start from any internal address. The master generating a STOP condition terminates the transfer.

## 4.4 Read operation

### 4.4.1 Current address byte read

Following the START condition the master sends a device select code with the RW bit set to 1. The STA335W acknowledges this and then responds by sending one byte of data. The master then terminates the transfer by generating a STOP condition.

### 4.4.2 Current address multi-byte read

The multi-byte read modes can start from any internal address. Sequential data bytes are read from sequential addresses within the STA335W. The master acknowledges each data byte read and then generates a STOP condition terminating the transfer.

### 4.4.3 Random address byte read

Following the START condition the master sends a device select code with the RW bit set to 0. The STA335W acknowledges this and then the master writes the internal address byte. After receiving, the internal byte address the STA335W again responds with an acknowledgement. The master then initiates another START condition and sends the device select code with the RW bit set to 1. The STA335W acknowledges this and then responds by sending one byte of data. The master then terminates the transfer by generating a STOP condition.

### 4.4.4 Random address multi-byte read

The multi-byte read modes could start from any internal address. Sequential data bytes are read from sequential addresses within the STA335W. The master acknowledges each data byte read and then generates a STOP condition terminating the transfer.

### 4.4.5 Write mode sequence

Figure 7. Write mode sequence

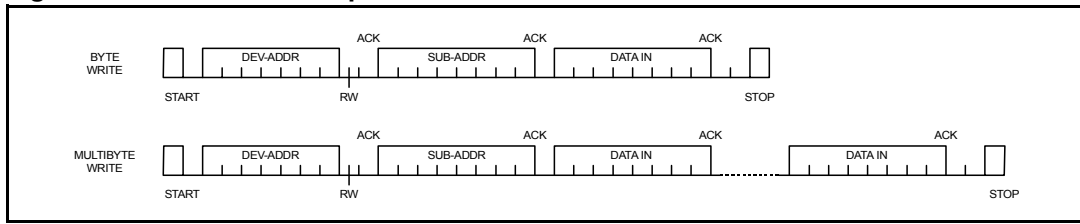

### 4.4.6 Read mode sequence

Figure 8. Read mode sequence

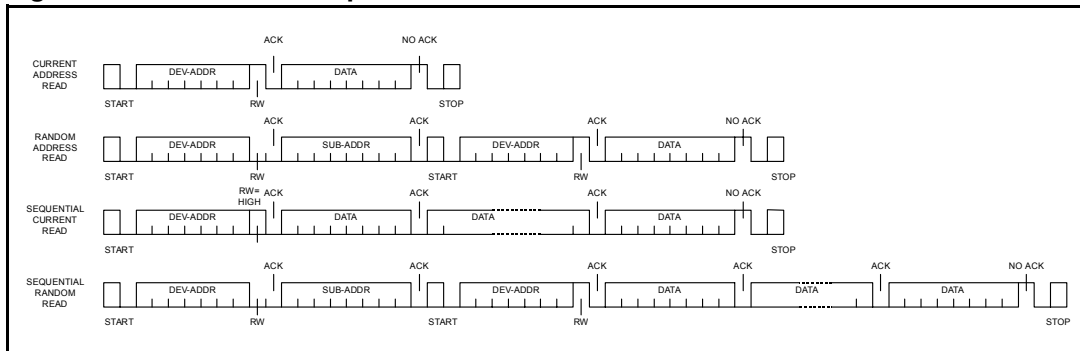

## 5 Register description

**Table 9. Register summary**

Addr	Name	D7	D6	D5	D4	D3	D2	D1	D0
0x00	CONF_A	FDRB	TWAB	TWRB	IR1	IR0	MCS2	MCS1	MCS0
0x01	CONF_B	C2IM	C1IM	Reserved	SAIFB	SAI3	SAI2	SAI1	SAI0
0x02	CONF_C	OCRB		CSZ3	CSZ2	CSZ1	CSZ0	OM1	OM0
0x03	CONF_D	Reserved	ZDE	Reserved	Reserved	PSL	Reserved	Reserved	Reserved
0x04	CONF_E	SVE	ZCE	DCCV	PWMS	AME	NSBW	MPC	MPCV
0x05	CONF_FF	EAPD	PWDN	ECLE	LDTE	BCLE	IDE	Reserved	Reserved
0x06	MUTE/LOC	Reserved	Reserved	Reserved	Reserved	Reserved	C2M	C1M	MMUTE
0x07	MVOL	MV7	MV6	MV5	MV4	MV3	MV2	MV1	MV0
0x08	C1VOL	C1V7	C1V6	C1V5	C1V4	C1V3	C1V2	C1V1	C1V0
0x09	C2VOL	C2V7	C2V6	C2V5	C2V4	C2V3	C2V2	C2V1	C2V0
0x0A		Reserved							
0x0B	AUTO1	Reserved	Reserved	Reserved	Reserved	Reserved	Reserved	Reserved	Reserved
0x0C	AUTO2	Reserved	Reserved	Reserved	Reserved	AMAM2	AMAM1	AMAM0	AMAME
0x0D		Reserved							
0x0E	C1CFG	Reserved	Reserved	Reserved	Reserved	C1BO	Reserved	Reserved	Reserved
0x0F	C2CFG	Reserved	Reserved	Reserved	Reserved	C2BO	Reserved	Reserved	Reserved
0x10		Reserved							
0x11		Reserved							
0x12		Reserved							
0x13		Reserved							
0x14		Reserved							
0x15		Reserved							
0x16	CFADDR	Reserved	Reserved	CFA5	CFA4	CFA3	CFA2	CFA1	CFA0
0x17	B1CF1	C1B23	C1B22	C1B21	C1B20	C1B19	C1B18	C1B17	C1B16
0x18	B1CF2	C1B15	C1B14	C1B13	C1B12	C1B11	C1B10	C1B9	C1B8
0x19	B1CF3	C1B7	C1B6	C1B5	C1B4	C1B3	C1B2	C1B1	C1B0
0x1A		Reserved							
0x1B		Reserved							
0x1C		Reserved							
0x1D		Reserved							
0x1E		Reserved							
0x1F		Reserved							



**Table 9. Register summary (continued)**

Addr	Name	D7	D6	D5	D4	D3	D2	D1	D0
0x20		Reserved							
0x21		Reserved							
0x22		Reserved							
0x23		Reserved							
0x24		Reserved							
0x25		Reserved							
0x26	CFUD	Reserved				Reserved	R1	Reserved	W1
0x27	MPCC1	MPCC15	MPCC14	MPCC13	MPCC12	MPCC11	MPCC10	MPCC9	MPCC8
0x28	MPCC2	MPCC7	MPCC6	MPCC5	MPCC4	MPCC3	MPCC2	MPCC1	MPCC0
0x29	DCC1	DCC15	DCC14	DCC13	DCC12	DCC11	DCC10	DCC9	DCC8
0x2A	DCC2	DCC7	DCC6	DCC5	DCC4	DCC3	DCC2	DCC1	DCC0
0x2B	FDRC1	FDRC15	FDRC14	FDRC13	FDRC12	FDRC11	FDRC10	FDRC9	FDRC8
0x2C	FDRC2	FDRC7	FDRC6	FDRC5	FDRC4	FDRC3	FDRC2	FDRC1	FDRC0
0x2D	STATUS	PLLUL	FAULT	UVFAULT	OVFAULT	OCFAULT	OCWARN	TFault	TWARN
0x2E	Reserved	Reserved		RO1BACT	R5BACT	R4BACT	R3BACT	R2BACT	R1BACT
0x2F	Reserved	Reserved		R01BEND	R5BEND	R4BEND	R3BEND	R2BEND	R1BEND
0x30	Reserved	Reserved			R5BBAD	R4BBAD	R3BBAD	R2BBAD	R1BBAD
0x31	EQCFG	XOB	Reserved	Reserved	AMGC3	AMGC2	Reserved	SEL1	SEL0
0x32		Reserved							
0x33		Reserved							
0x34		Reserved							
0x35		Reserved							
0x36		Reserved							
0x37		Reserved	Reserved	SVUPE	SVUP[4]	SVUP[3]	SVUP[2]	SVUP[1]	SVUP[0]
0x38		Reserved	Reserved	SVDWE	SVDW[4]	SVDW[3]	SVDW[2]	SVDW[1]	SVDW[0]

### 5.1 Configuration register A (addr 0x00)

D7	D6	D5	D4	D3	D2	D1	D0
FDRB	TWAB	TWRB	IR1	IR0	MCS2	MCS1	MCS0
0	1	1	0	0	0	1	1

### 5.1.1 Master clock select

**Table 10. Master clock select**

Bit	R/W	RST	Name	Description
0	R/W	1	MCS0	Selects the ratio between the input I <sup>2</sup> S sample frequency and the input clock.
1	R/W	1	MCS1	
2	R/W	0	MCS2	

The STA335W supports sample rates of 32 kHz, 44.1 kHz, 48 kHz, 88.2 kHz, 96 kHz, 176.4 kHz, and 192 kHz. Therefore the internal clock is:

- 32.768 MHz for 32 kHz
- 45.1584 MHz for 44.1 kHz, 88.2 kHz, and 176.4 kHz
- 49.152 MHz for 48 kHz, 96 kHz, and 192 kHz

The external clock frequency provided to the XTI pin must be a multiple of the input sample frequency ( $f_s$ ).

The relationship between the input clock and the input sample rate is determined by both the MCSx and the IR (input rate) register bits. The MCSx bits determine the PLL factor generating the internal clock and the IR bit determines the oversampling ratio used internally.

**Table 11. Input sampling rates**

Input sample rate $f_s$ (kHz)	IR	MCS[2:0]					
		101	100	011	010	001	000
32, 44.1, 48	00	576 * $f_s$	128 * $f_s$	256 * $f_s$	384 * $f_s$	512 * $f_s$	768 * $f_s$
88.2, 96	01	NA	64 * $f_s$	128 * $f_s$	192 * $f_s$	256 * $f_s$	384 * $f_s$
176.4, 192	1X	NA	32 * $f_s$	64 * $f_s$	96 * $f_s$	128 * $f_s$	192 * $f_s$

### 5.1.2 Interpolation ratio select

**Table 12. Internal interpolation ratio**

Bit	R/W	RST	Name	Description
4:3	R/W	00	IR [1:0]	Selects internal interpolation ratio based on input I <sup>2</sup> S sample frequency

The STA335W has variable interpolation (oversampling) settings such that internal processing and FFX output rates remain consistent. The first processing block interpolates by either 2-times or 1-time (pass-through) or provides a 2-times downsample. The oversampling ratio of this interpolation is determined by the IR bits.

**Table 13. IR bit settings as a function of input sample rate**

Input sample rate fs (kHz)	IR	1st stage interpolation ratio
32	00	2 times oversampling
44.1	00	2 times oversampling
48	00	2 times oversampling
88.2	01	Pass-through
96	01	Pass-through
176.4	10	2 times downsampling
192	10	2 times downsampling

### 5.1.3 Thermal warning recovery bypass

**Table 14. Thermal warning recovery bypass**

Bit	R/W	RST	Name	Description
5	R/W	1	TWRB	0: Thermal warning recovery enabled 1: Thermal warning recovery disabled

If the thermal warning adjustment is enabled (TWAB = 0), then the thermal warning recovery determines if the -3 dB output limit is removed when thermal warning is negative.

If TWRB = 0 and TWAB = 0, then when a thermal warning disappears the -3 dB output limit is removed and the gain is added back to the system. If TWRB = 1 and TWAB = 0, then when a thermal warning disappears the -3 dB output limit remains until TWRB is changed to zero or the device is reset.

### 5.1.4 Thermal warning adjustment bypass

**Table 15. Thermal warning adjustment bypass**

Bit	R/W	RST	Name	Description
6	R/W	1	TWAB	0: Thermal warning adjustment enabled 1: Thermal warning adjustment disabled

The on-chip STA335W power output block provides feedback to the digital controller using inputs to the power control block. Input TWARN is used to indicate a thermal warning

condition. When TWARN is asserted (set to 0) for a period of time greater than 400 ms, the power control block forces a -3 dB output limit (determined by TWOCL in the coefficient RAM) to the modulation limit in an attempt to eliminate the thermal warning condition. Once the thermal warning output limit adjustment is applied, it remains in this state until reset, unless FDRB = 0.

### 5.1.5 Fault detect recovery bypass

**Table 16. Fault detect recovery bypass**

Bit	R/W	RST	Name	Description
7	R/W	0	FDRB	0: fault detect recovery enabled 1: fault detect recovery disabled

The on-chip STA335W power output block provides feedback to the digital controller using inputs to the power control block. The FAULT input is used to indicate a fault condition (either over-current or thermal). When FAULT is asserted (set to 0), the power control block attempts a recovery from the fault by asserting the tri-state output (setting it to 0 which directs the power output block to begin recovery), holds it at 0 for period of time in the range of 0.1 ms to 1 second as defined by the fault-detect recovery constant register (FDRC registers 0x29-0x2A), then toggles it back to 1. This sequence is repeated as long as the fault indication exists. This feature is enabled by default but can be bypassed by setting the FDRB control bit to 1.

## 5.2 Configuration register B (addr 0x01)

D7	D6	D5	D4	D3	D2	D1	D0
C2IM	C1IM	DSCKE	SAIFB	SAI3	SAI2	SAI1	SAI0
1	0	0	0	0	0	0	0

### 5.2.1 Serial audio input interface format

**Table 17. Serial audio input interface**

Bit	R/W	RST	Name	Description
0	R/W	0	SAI0	Determines the interface format of the input serial digital audio interface.
1	R/W	0	SAI1	
2	R/W	0	SAI2	
3	R/W	0	SAI3	

### 5.2.2 Serial data interface

The STA335W audio serial input was designed to interface with standard digital audio components and to accept a number of serial data formats. STA335W always acts as slave when receiving audio input from standard digital audio components. Serial data for two channels is provided using three inputs: left/right clock LRCKI, serial clock BICKI, and serial data 1 and 2 SDI12.

The SAI bits (D3 to D0) and the SAIFB bit (D4) are used to specify the serial data format. The default serial data format is I<sup>2</sup>S, MSB-first. Available formats are shown in the tables and figure that follow.

### 5.2.3 Serial data first bit

**Table 18. Serial data first bit**

SAIFB	Format
0	MSB-first
1	LSB-first

**Table 19. Support serial audio input formats for MSB-first (SAIFB = 0)**

BICKI	SAI [3:0]	SAIFB	Interface format
32 * fs	0000	0	I <sup>2</sup> S 15-bit data
	0001	0	Left/right-justified 16-bit data
48 * fs	0000	0	I <sup>2</sup> S 16 to 23-bit data
	0001	0	Left-justified 16 to 24-bit data
	0010	0	Right-justified 24-bit data
	0110	0	Right-justified 20-bit data
	1010	0	Right-justified 18-bit data
	1110	0	Right-justified 16-bit data
64 * fs	0000	0	I <sup>2</sup> S 16 to 24-bit data
	0001	0	Left-justified 16 to 24-bit data
	0010	0	Right-justified 24-bit data
	0110	0	Right-justified 20-bit data
	1010	0	Right-justified 18-bit data
	1110	0	Right-justified 16-bit data

Table 20. Supported serial audio input formats for LSB-first (SAIFB = 1)

BICKI	SAI [3:0]	SAIFB	Interface Format
32 * fs	1100	1	I <sup>2</sup> S 15-bit data
	1110	1	Left/right-justified 16-bit data
48 * fs	0100	1	I <sup>2</sup> S 23-bit data
	0100	1	I <sup>2</sup> S 20-bit data
	1000	1	I <sup>2</sup> S 18-bit data
	1100	1	LSB first I <sup>2</sup> S 16-bit data
	0001	1	Left-justified 24-bit data
	0101	1	Left-justified 20-bit data
	1001	1	Left-justified 18-bit data
	1101	1	Left-justified 16-bit data
	0010	1	Right-justified 24-bit data
	0110	1	Right-justified 20-bit data
	1010	1	Right-justified 18-bit data
	1110	1	Right-justified 16-bit data
64 * fs	0000	1	I <sup>2</sup> S 24-bit data
	0100	1	I <sup>2</sup> S 20-bit data
	1000	1	I <sup>2</sup> S 18-bit data
	1100	1	LSB first I <sup>2</sup> S 16-bit data
	0001	1	Left-justified 24-bit data
	0101	1	Left-justified 20-bit data
	1001	1	Left-justified 18-bit data
	1101	1	Left-justified 16-bit data
	0010	1	Right-justified 24-bit data
	0110	1	Right-justified 20-bit data
	1010	1	Right-justified 18-bit data
	1110	1	Right-justified 16-bit data

To make the STA335W work properly, the serial audio interface LRCKI clock must be synchronous to the PLL output clock. It means that:

- the frequency of PLL clock / frequency of LRCKI =  $N \pm 4$  cycles, where N depends on the settings in [Table 13 on page 19](#)
- the PLL must be locked.

If these two conditions are not met, and IDE bit (reg 0x05 bit 2) is set to 1, the STA335W will immediately mute the I<sup>2</sup>S PCM data out (provided to the processing block) and it will freeze any active processing task.

To avoid any audio side effects (like pop noise), it is strongly recommended to soft mute any audio streams flowing into STA335W data path before the desynchronization event

happens. At the same time any processing related to the I<sup>2</sup>C configuration should be issued only after the serial audio interface and the internal PLL are synchronous again.

*Note: Any mute or volume change causes some delay in the completion of the I<sup>2</sup>C operation due to the soft volume feature. The soft volume phase change must be finished before any clock desynchronization.*

### 5.2.4 Channel input mapping

**Table 21. Channel input mapping**

Bit	R/W	RST	Name	Description
6	R/W	0	C1IM	0: Processing channel 1 receives Left I <sup>2</sup> S Input 1: Processing channel 1 receives Right I <sup>2</sup> S Input
7	R/W	1	C2IM	0: Processing channel 2 receives Left I <sup>2</sup> S Input 1: Processing channel 2 receives Right I <sup>2</sup> S Input

Each channel received via I<sup>2</sup>S can be mapped to any internal processing channel via the Channel Input Mapping registers. This allows for flexibility in processing. The default settings of these registers map each I<sup>2</sup>S input channel to its corresponding processing channel.

### 5.3 Configuration register C (addr 0x02)

D7	D6	D5	D4	D3	D2	D1	D0
OCRB		CSZ3	CSZ2	CSZ1	CSZ0	OM1	OM0
1		0	1	1	1	1	1

#### 5.3.1 FFX power output mode

Table 22. FFX power output mode

Bit	R/W	RST	Name	Description
0	R/W	1	OM0	Selects configuration of FFX output.
1	R/W	1	OM1	

The FFX power output mode selects how the FFX output timing is configured. Different power devices use different output modes.

Table 23. Output modes

OM[1,0]	Output stage mode
00	Drop compensation
01	Discrete output stage - tapered compensation
10	Full power mode
11	Variable drop compensation (CSZx bits)

#### 5.3.2 FFX compensating pulse size register

Table 24. FFX compensating pulse size bits

Bit	R/W	RST	Name	Description
2	R/W	1	CSZ0	When OM[1,0] = 11, this register determines the size of the FFX compensating pulse from 0 clock ticks to 15 clock periods.
3	R/W	1	CSZ1	
4	R/W	1	CSZ2	
5	R/W	0	CSZ3	

Table 25. Compensating pulse size

CSZ[3:0]	Compensating Pulse Size
0000	0 ns (0 tick) compensating pulse size
0001	20 ns (1 tick) clock period compensating pulse size
...	...
1111	300 ns (15 tick) clock period compensating pulse size



### 5.3.3 Over-current warning detect adjustment bypass

**Table 26. Over-current warning bypass**

Bit	R/W	RST	Name	Description
7	R/W	1	OCRB	0: Over-Current warning adjustment enabled 1: Over-Current warning adjustment disabled

The OCWARN input is used to indicate an over-current warning condition. When OCWARN is asserted (set to 0), the power control block forces an adjustment to the modulation limit (default is -3 dB) in an attempt to eliminate the over-current warning condition. Once the over-current warning volume adjustment is applied, it remains in this state until reset is applied. The level of adjustment can be changed via the TWOCL (thermal warning/over current limit) setting which is address 0x37 of the user defined coefficient RAM.

## 5.4 Configuration register D (addr 0x03)

D7	D6	D5	D4	D3	D2	D1	D0
Reserved	ZDE	Reserved	Reserved	PSL	Reserved	Reserved	Reserved
0	1	0	0	0	0	0	0

### 5.4.1 Post-scale link

**Table 27. Post-scale link**

Bit	R/W	RST	Name	Description
3	R/W	0	PSL	0: Each channel uses individual post-scale value 1: Each channel uses channel 1 post-scale value

Post-scale functionality can be used for power-supply error correction. For multi-channel applications running off the same power-supply, the post-scale values can be linked to the value of channel 1 for ease of use and update the values faster.

### 5.4.2 Zero-detect mute enable

**Table 28. Zero-detect mute enable**

Bit	R/W	RST	Name	Description
6	R/W	1	ZDE	Setting of 1 enables the automatic zero-detect mute

Setting the ZDE bit enables the zero-detect automatic mute. The zero-detect circuit looks at the data for each processing channel at the output of the crossover (bass management) filter. If any channel receives 2048 consecutive zero value samples (regardless of fs) then that individual channel is muted if this function is enabled.

## 5.5 Configuration register E (addr 0x04)

D7	D6	D5	D4	D3	D2	D1	D0
SVE	ZCE	DCCV	PWMS	AME	NSBW	MPC	MPCV

D7	D6	D5	D4	D3	D2	D1	D0
1	1	0	0	0	0	1	0

### 5.5.1 Max power correction variable

**Table 29. Max power correction variable**

Bit	R/W	RST	Name	Description
0	R/W	0	MPCV	0: Use standard MPC coefficient 1: Use MPCC bits for MPC coefficient

### 5.5.2 Max power correction

**Table 30. Max power correction**

Bit	R/W	RST	Name	Description
1	R/W	1	MPC	Setting of 1 enables Power Bridge correction for THD reduction near maximum power output.

Setting the MPC bit turns on special processing that corrects the STA335W power device at high power. This mode should lower the THD+N of a full FFX system at maximum power output and slightly below. If enabled, MPC is operational in all output modes except tapered (OM[1,0] = 01) and binary. When OCFG = 00, MPC will not effect channels 3 and 4, the line-out channels.

### 5.5.3 Noise-shaper bandwidth selection

**Table 31. Noise-shaper bandwidth selection**

Bit	R/W	RST	Name	Description
2	R/W	0	NSBW	1: Third order NS 0: Fourth order NS

### 5.5.4 AM mode enable

**Table 32. AM mode enable**

Bit	R/W	RST	Name	Description
3	R/W	0	AME	0: Normal FFX operation. 1: AM reduction mode FFX operation

STA335W features aFFX processing mode that minimizes the amount of noise generated in frequency range of AM radio. This mode is intended for use when FFX is operating in a device with an AM tuner active. The SNR of the FFX processing is reduced to approximately 83 dB in this mode, which is still greater than the SNR of AM radio.

### 5.5.5 PWM speed mode

Table 33. PWM speed mode

Bit	R/W	RST	Name	Description
4	R/W	0	PWMS	0: Normal speed (384 kHz) all channels 1: Odd speed (341.3 kHz) all channels

### 5.5.6 Distortion compensation variable enable

Table 34. Distortion compensation variable enable

Bit	R/W	RST	Name	Description
5	R/W	0	DCCV	0: Use preset DC coefficient 1: Use DCC coefficient

### 5.5.7 Zero-crossing volume enable

Table 35. Zero-crossing volume enable

Bit	R/W	RST	Name	Description
6	R/W	1	ZCE	1: Volume adjustments only occur at digital zero-crossings 0: Volume adjustments occur immediately

The ZCE bit enables zero-crossing volume adjustments. When volume is adjusted on digital zero-crossings no clicks are audible.

### 5.5.8 Soft volume update enable

Table 36. Soft volume update enable

Bit	R/W	RST	Name	Description
7	R/W	1	SVE	1: Volume adjustments ramp according to SVR settings 0: Volume adjustments occur immediately

## 5.6 Configuration register F (addr 0x05)

D7	D6	D5	D4	D3	D2	D1	D0
EAPD	PWDN	ECLE	LDTE	BCLE	IDE	Reserved	Reserved
0	1	0	1	1	1	0	0

### 5.6.1 Invalid input detect mute enable

**Table 37. Invalid input detect mute enable**

Bit	R/W	RST	Name	Description
2	R/W	1	IDE	Setting of 1 enables the automatic invalid input detect mute

Setting the IDE bit enables this function, which looks at the input I<sup>2</sup>S data and automatically mutes if the signals are perceived as invalid.

### 5.6.2 Binary output mode clock loss detection

**Table 38. Binary output mode clock loss detection**

Bit	R/W	RST	Name	Description
3	R/W	1	BCLE	Binary output mode clock loss detection enable

Detects loss of input MCLK in binary mode and will output 50% duty cycle.

### 5.6.3 LRCK double trigger protection

**Table 39. LRCK double trigger protection**

Bit	R/W	RST	Name	Description
4	R/W	1	LDTE	LRCLK double trigger protection enable

Actively prevents double trigger of LRCLK.

### 5.6.4 Auto EAPD on clock loss

**Table 40. Auto EAPD on clock loss**

Bit	R/W	RST	Name	Description
5	R/W	0	ECLE	Auto EAPD on clock loss

When active, issues a power device power down signal (EAPD) on clock loss detection.

### 5.6.5 IC power down

**Table 41. IC power down**

Bit	R/W	RST	Name	Description
6	R/W	1	PWDN	0: IC power down low-power condition 1: IC normal operation

The PWDN register is used to place the IC in a low-power state. When PWDN is written as 0, the output begins a soft-mute. After the mute condition is reached, EAPD is asserted to power down the power-stage, then the master clock to all internal hardware except the I<sup>2</sup>C block is gated. This places the IC in a very low power consumption state.

### 5.6.6 Amplifier power down

**Table 42. External amplifier power down**

Bit	R/W	RST	Name	Description
7	R/W	0	EAPD	0: Power stage power down active 1: Normal operation

The EAPD register directly disables/enables the internal power circuitry.

When EAPD = 0, the internal power section is placed on a low-power state (disabled).

## 5.7 Volume control registers (addr 0x06 - 0x0A)

### 5.7.1 Mute/line output configuration register

D7	D6	D5	D4	D3	D2	D1	D0
LOC1	LOC0	Reserved	Reserved	C3M	C2M	C1M	MMUTE
0	0	0	0	0	0	0	0

**Table 43. Line output configuration**

LOC[1:0]	Line output configuration
00	Line output fixed - no volume, no EQ
01	Line output variable - CH3 volume effects line output, no EQ
10	Line output variable with EQ - CH3 volume effects line output

Line output is only active when OCFG = 00. In this case LOC determines the line output configuration. The source of the line output is always the channel 1 and 2 inputs.

### 5.7.2 Master volume register

D7	D6	D5	D4	D3	D2	D1	D0
MV7	MV6	MV5	MV4	MV3	MV2	MV1	MV0
1	1	1	1	1	1	1	1

### 5.7.3 Channel 1 volume

D7	D6	D5	D4	D3	D2	D1	D0
C1V7	C1V6	C1V5	C1V4	C1V3	C1V2	C1V1	C1V0
0	1	1	0	0	0	0	0

### 5.7.4 Channel 2 volume

D7	D6	D5	D4	D3	D2	D1	D0
C2V7	C2V6	C2V5	C2V4	C2V3	C2V2	C2V1	C2V0
0	1	1	0	0	0	0	0

The Volume structure of the STA335W consists of individual volume registers for each channel and a master volume register that provides an offset to each channels volume setting. The individual channel volumes are adjustable in 0.5 dB steps from +48 dB to -80 dB.

As an example if C1V = 0x00 or +48 dB and MV = 0x18 or -12 dB, then the total gain for channel 1 = +36 dB.

The master mute, when set to 1, mutes all channels at once, whereas the individual channel mutes (CxM) mutes only that channel. Both the master mute and the channel mutes provide a “soft mute” with the volume ramping down to mute in 4096 samples from the maximum volume setting at the internal processing rate (approximately 96 kHz).

A “hard (instantaneous) mute” can be obtained by programming a value of 0xFF (255) to any channel volume register or the master volume register. When volume offsets are provided via the master volume register any channel whose total volume is less than -80 dB is muted.

All changes in volume take place at zero-crossings when ZCE = 1 ([Configuration register E \(addr 0x04\) on page 25](#)) on a per channel basis as this creates the smoothest possible volume transitions. When ZCE = 0, volume updates occur immediately.

**Table 44. Master volume offset as a function of MV[7:0]**

MV[7:0]	Volume offset from channel value
00000000 (0x00)	0 dB
00000001 (0x01)	-0.5 dB
00000010 (0x02)	-1 dB
...	...
01001100 (0x4C)	-38 dB
...	...
11111110 (0xFE)	-127.5 dB
11111111 (0xFF)	Hard master mute

**Table 45. Channel volume as a function of CxV[7:0]**

CxV[7:0]	Volume
00000000 (0x00)	+48 dB
00000001 (0x01)	+47.5 dB
00000010 (0x02)	+47 dB
...	...
01011111 (0x5F)	+0.5 dB
01100000 (0x60)	0 dB
01100001 (0x61)	-0.5 dB
...	...
11010111 (0xD7)	-59.5 dB
11011000 (0xD8)	-60 dB

**Table 45. Channel volume as a function of CxV[7:0] (continued)**

CxV[7:0]	Volume
11011001 (0xD9)	-61 dB
11011010 (0xDA)	-62 dB
...	...
11101100 (0xEC)	-80 dB
11101101 (0xED)	Hard channel mute
...	...
11111111 (0xFF)	Hard channel mute

## 5.8 Audio preset registers (0x0C)

### 5.8.1 Audio preset register 2 (addr 0x0C)

D7	D6	D5	D4	D3	D2	D1	D0
XO3	XO2	XO1	XO0	AMAM2	AMAM1	AMAM0	AMAME
0	0	0	0	0	0	0	0

### 5.8.2 AM interference frequency switching

**Table 46. AM interference frequency switching bits**

Bit	R/W	RST	Name	Description
0	R/W	0	AMAME	Audio preset AM enable 0: switching frequency determined by PWMS setting 1: switching frequency determined by AMAM settings

**Table 47. Audio preset AM switching frequency selection**

AMAM[2:0]	48 kHz/96 kHz input fs	44.1 kHz/88.2 kHz input fs
000	0.535 MHz - 0.720 MHz	0.535 MHz - 0.670 MHz
001	0.721 MHz - 0.900 MHz	0.671 MHz - 0.800 MHz
010	0.901 MHz - 1.100 MHz	0.801 MHz - 1.000 MHz
011	1.101 MHz - 1.300 MHz	1.001 MHz - 1.180 MHz
100	1.301 MHz - 1.480 MHz	1.181 MHz - 1.340 MHz
101	1.481 MHz - 1.600 MHz	1.341 MHz - 1.500 MHz
110	1.601 MHz - 1.700 MHz	1.501 MHz - 1.700 MHz

## 5.9 User-defined coefficient control registers (addr 0x16 - 0x26)

### 5.9.1 Coefficient address register

D7	D6	D5	D4	D3	D2	D1	D0
		CFA5	CFA4	CFA3	CFA2	CFA1	CFA0
		0	0	0	0	0	0

### 5.9.2 Coefficient data register bits 23:16

D7	D6	D5	D4	D3	D2	D1	D0
C1B23	C1B22	C1B21	C1B20	C1B19	C1B18	C1B17	C1B16
0	0	0	0	0	0	0	0

### 5.9.3 Coefficient data register bits 15:8

D7	D6	D5	D4	D3	D2	D1	D0
C1B15	C1B14	C1B13	C1B12	C1B11	C1B10	C1B9	C1B8
0	0	0	0	0	0	0	0

### 5.9.4 Coefficient data register bits 7:0

D7	D6	D5	D4	D3	D2	D1	D0
C1B7	C1B6	C1B5	C1B4	C1B3	C1B2	C1B1	C1B0
0	0	0	0	0	0	0	0

### 5.9.5 Coefficient write/read control register

D7	D6	D5	D4	D3	D2	D1	D0
Reserved				Reserved	R1	Reserved	W1
0				0	0	0	0

Coefficients for user-defined scaling are handled internally in the STA335W via RAM. Access to this RAM is available to the user via an I<sup>2</sup>C register interface. A collection of I<sup>2</sup>C registers are dedicated to this function. One contains a coefficient base address, five sets of three store the values of the 24-bit coefficients to be written or that were read, and one contains bits used to control the write/read of the coefficient(s) to/from RAM.

*Note:* The read and write operation on RAM coefficients works only if LRCKI (pin 29) is switching.

#### Reading a coefficient from RAM

1. Select the RAM block with register 0x31 bit1, bit0.
2. Write 6-bits of address to I<sup>2</sup>C register 0x16.
3. Write 1 to R1 bit in I<sup>2</sup>C address 0x26.
4. Read top 8-bits of coefficient in I<sup>2</sup>C address 0x17.
5. Read middle 8-bits of coefficient in I<sup>2</sup>C address 0x18.
6. Read bottom 8-bits of coefficient in I<sup>2</sup>C address 0x19.



**Writing a single coefficient to RAM**

1. Select the RAM block with register 0x31 bit1, bit0.
2. Write 6-bits of address to I<sup>2</sup>C register 0x16.
3. Write top 8-bits of coefficient in I<sup>2</sup>C address 0x17.
4. Write middle 8-bits of coefficient in I<sup>2</sup>C address 0x18.
5. Write bottom 8-bits of coefficient in I<sup>2</sup>C address 0x19.
6. Write 1 to W1 bit in I<sup>2</sup>C address 0x26.

**5.9.6 Post-scale**

The STA335W provides one additional multiplication after the last interpolation stage and the distortion compensation on each channel. This post-scaling is accomplished by using a 24-bit signed fractional multiplier, with 0x800000 = -1 and 0x7FFFFFFF = 0.9999998808. The scale factor for this multiply is loaded into RAM using the same I<sup>2</sup>C registers as the biquad coefficients and the bass-management. This post-scale factor can be used in conjunction with an ADC equipped micro-controller to perform power-supply error correction. All channels can use the channel-1 post-scale factor by setting the post-scale link bit. By default, all post-scale factors are set to 0x7FFFFFFF. When line output is being used, channel-3 post-scale will affect both channels 3 and 4.

**5.9.7 Over-current post-scale**

The STA335W provides a simple mechanism for reacting to over-current detection in the power-block. When the ocwarn input is asserted, the over-current post-scale value is used in place of the normal post-scale value to provide output attenuation on all channels. The default setting provides 3 dB of output attenuation when ocwarn is asserted.

The amount of attenuation to be applied in this situation can be adjusted by modifying the Over-current Post-scale value. As with the normal post-scale, this scaling value is a 24-bit signed fractional multiplier, with 0x800000 = -1 and 0x7FFFFFFF = 0.9999998808. By default, the over-current post-scale factor is set to 0x5A9DF7. Once the over-current attenuation is applied, it remains until the device is reset.

**Table 48. RAM block for scaling management**

Index (Decimal)	Index (Hex)		Coefficient	Default
0		Reserved		
...	...	Reserved		
52	0x34	Channel 1 - Post-Scale	C1PstS	0x7FFFFFFF
53	0x35	Channel 2 - Post-Scale	C2PstS	0x7FFFFFFF
54	0x36	Reserved		
55	0x37	TWARN/OC - Limit	TWOCL	0x5A9DF7

**5.10 Variable max power correction registers (addr 0x27 - 0x28)**

D7	D6	D5	D4	D3	D2	D1	D0
MPCC15	MPCC14	MPCC13	MPCC12	MPCC11	MPCC10	MPCC9	MPCC8

D7	D6	D5	D4	D3	D2	D1	D0
0	0	0	1	1	0	1	0

D7	D6	D5	D4	D3	D2	D1	D0
MPCC7	MPCC6	MPCC5	MPCC4	MPCC3	MPCC2	MPCC1	MPCC0
1	1	0	0	0	0	0	0

MPCC bits determine the 16 MSBs of the MPC compensation coefficient. This coefficient is used in place of the default coefficient when MPCV = 1.

## 5.11 Variable distortion compensation registers (addr 0x29 - 0x2A)

D7	D6	D5	D4	D3	D2	D1	D0
DCC15	DCC14	DCC13	DCC12	DCC11	DCC10	DCC9	DCC8
1	1	1	1	0	0	1	1

D7	D6	D5	D4	D3	D2	D1	D0
DCC7	DCC6	DCC5	DCC4	DCC3	DCC2	DCC1	DCC0
0	0	1	1	0	0	1	1

DCC bits determine the 16 MSBs of the Distortion compensation coefficient. This coefficient is used in place of the default coefficient when DCCV = 1.

## 5.12 Fault detect recovery constant registers (addr 0x2B - 0x2C)

D7	D6	D5	D4	D3	D2	D1	D0
FDRC15	FDRC14	FDRC13	FDRC12	FDRC11	FDRC10	FDRC9	FDRC8
0	0	0	0	0	0	0	0

D7	D6	D5	D4	D3	D2	D1	D0
FDRC7	FDRC6	FDRC5	FDRC4	FDRC3	FDRC2	FDRC1	FDRC0
0	0	0	0	1	1	0	0

FDRC bits specify the 16-bit fault detect recovery time delay. When FAULT is asserted, the TRISTATE output is immediately asserted low and held low for the time period specified by this constant. A constant value of 0x0001 in this register is approximately 0.083 ms. The default value of 0x000C gives approximately 0.1 ms.

## 5.13 Device status register (addr 0x2D)

D7	D6	D5	D4	D3	D2	D1	D0
PLLUL	FAULT	UVFAULT	OVFAULT	OCFAULT	OCWARN	TFAULT	TWARN

This read-only register provides fault and thermal-warning status information from the power control block. Logic value 1 for faults or warning means normal state. Logic 0 means a fault or warning detected on power bridge. The PLLUL = 1 means that the PLL is not locked.

**Table 49. Status register bits**

Bit	R/W	RST	Name	Description
7	R	-	PLLUL	0: PLL locked 1: PLL not locked
6	R	-	FAULT	0: fault detected on power bridge 1: normal operation
5	R	-	UVFAULT	0: VCCxX internally detected < undervoltage threshold
4	R	-	OVFAULT	0: VCCxX internally detected > overvoltage threshold
3	R	-	OCFAULT	0: overcurrent fault detected
2	R	-	OCWARN	0: overcurrent warning
1	R	-	TFAULT	0: thermal fault, junction temperature over limit detection
0	R	-	TWARN	0: thermal warning, junction temperature is close to the fault condition

**5.13.1 Extended Soft Volume configuration registers (addr 0x37 - 0x38)**

D7	D6	D5	D4	D3	D2	D1	D0
		SVUPE	SVUP[4]	SVUP[3]	SVUP[2]	SVUP[1]	SVUP[0]
0	0	0	0	0	0	0	0

D7	D6	D5	D4	D3	D2	D1	D0
		SVDWE	SVDW[4]	SVDW[3]	SVDW[2]	SVDW[1]	SVDW[0]
0	0	0	0	0	0	0	0

Soft volume update has a fixed rate by default. Using register 0x37 and 0x38 it is possible to override the default behavior allowing different volume change rates.

It is also possible to independently define the fade-in (volume is increased) and fade-out (volume is decreased) rates according to the desired behavior.

SVUPE	Mode
0	When volume is increased, use the default rate
1	When volume is increased, use the rates defined by SVUP[4:0] .

When SVUPE = 1 the fade-in rate is defined by the SVUP[4:0] bits according to the following formula:

$$\text{Fade-in rate} = 48 / (N + 1) \text{ dB/ms}$$

where N is the SVUP[4:0] value.

SVDWE	Mode
0	When volume is decreased, use the default rate
1	When volume is decreased, use the rates defined by SVDW[4:0] .

When SVDWE = 1 the fade-out rate is defined by the SVDW[4:0] bits according to the following formula:

$$\text{Fade-in rate} = 48 / (N + 1) \text{ dB/ms}$$

where N is the SVDW[4:0] value.

## 6 Application

### 6.1 Application scheme for power supplies

Here in the next figure the typical application scheme for STA335W concerning the power supplies. A particular care has to be devoted to the layout of the PCB. In particular all the decoupling capacitors have to be put as much as possible closed to the device to limit spikes on all the supplies.

Figure 9. Application scheme for power supplies

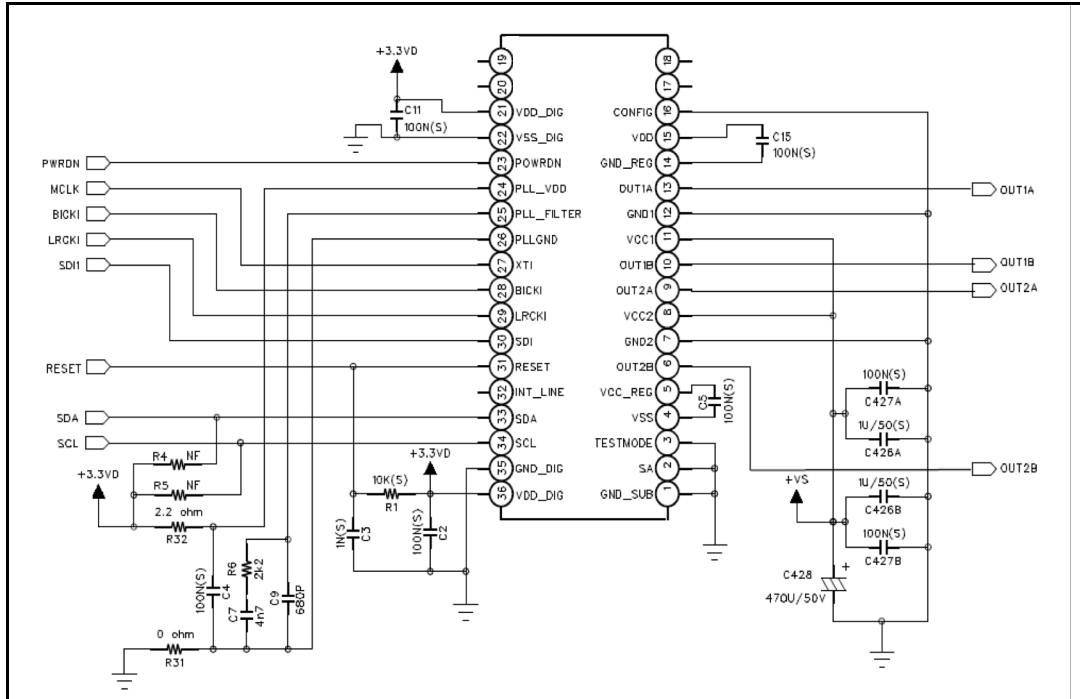

### 6.2 PLL filter schematic

It is recommended to use the above scheme and values for the PLL loop filter to achieve the best performances from the device in general application. Please be noted that the ground of this filter scheme has to be connected to the ground of the PLL without any resistive path. Concerning the component values, please take into account that the greater is the filter bandwidth, the less is the lock time but the higher is the PLL output jitter.

### 6.3 Typical output configuration

Here after the typical output configuration used for BTL stereo mode. Please refer to the application note for all the other possible output configuration recommended schematics.

Figure 10. Output configuration for stereo BTL mode

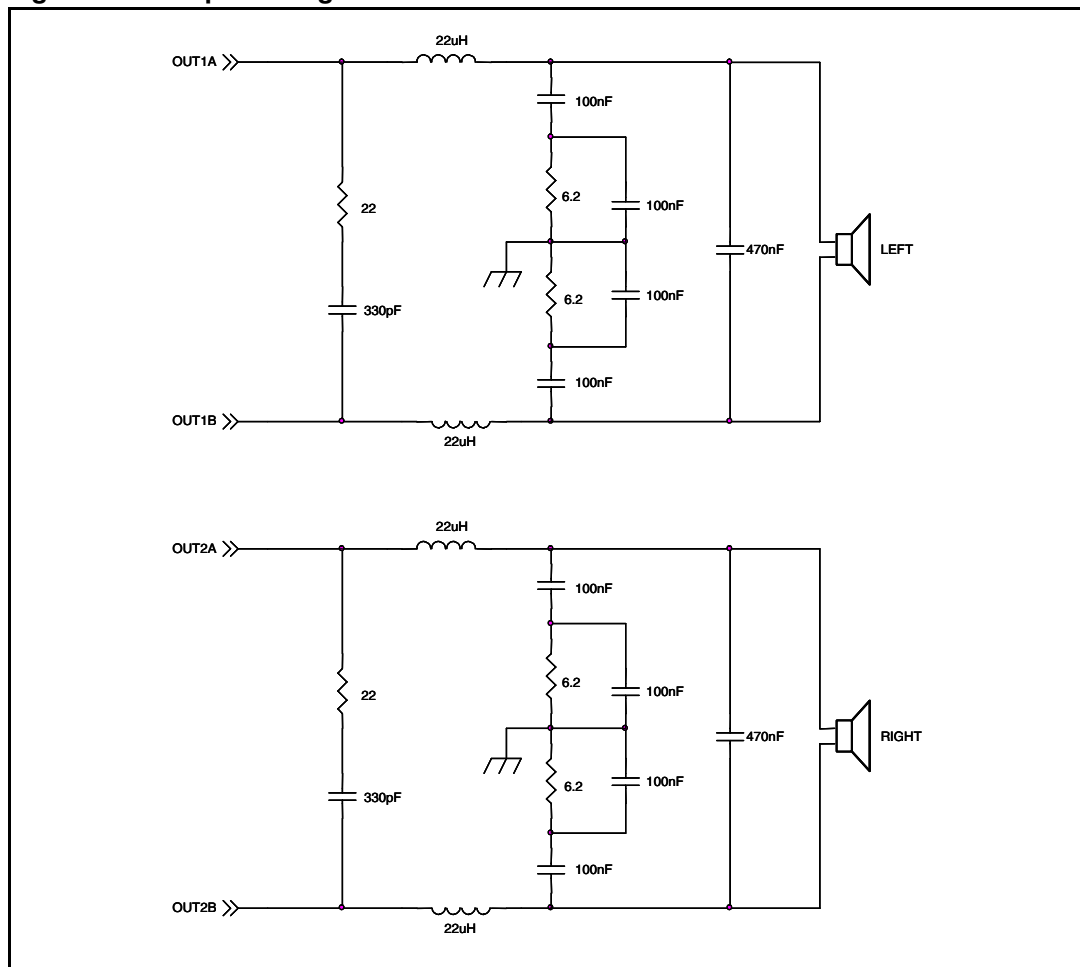

## 7 Package thermal characteristics

Using a double-layer PCB the thermal resistance junction to ambient with 2 copper ground areas of 3 x 3 cm<sup>2</sup> and with 16 via holes (see [Figure 11](#)) is 24 °C/W in natural air convection.

The dissipated power within the device depends primarily on the supply voltage, load impedance and output modulation level.

Thus, the maximum estimated dissipated power for the STA335W is:

$$\begin{aligned}
 &2 \times 20 \text{ W @ } 8 \Omega, 18 \text{ V} && P_d \text{ max } \sim 4 \text{ W} \\
 &2 \times 10 \text{ W} + 1 \times 20 \text{ W @ } 4 \Omega, 8 \Omega, 18 \text{ V} && P_d \text{ max } < 5 \text{ W}
 \end{aligned}$$

**Figure 11. Double-layer PCB with 2 copper ground areas and 16 via holes**

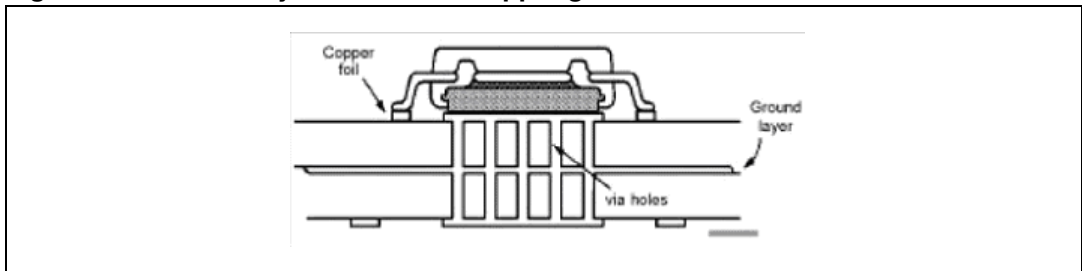

[Figure 12](#) shows the power derating curve for the PowerSSO-36 package on PCBs with copper areas of 2 x 2 cm<sup>2</sup> and 3 x 3 cm<sup>2</sup>.

**Figure 12. PowerSSO-36 power derating curve**

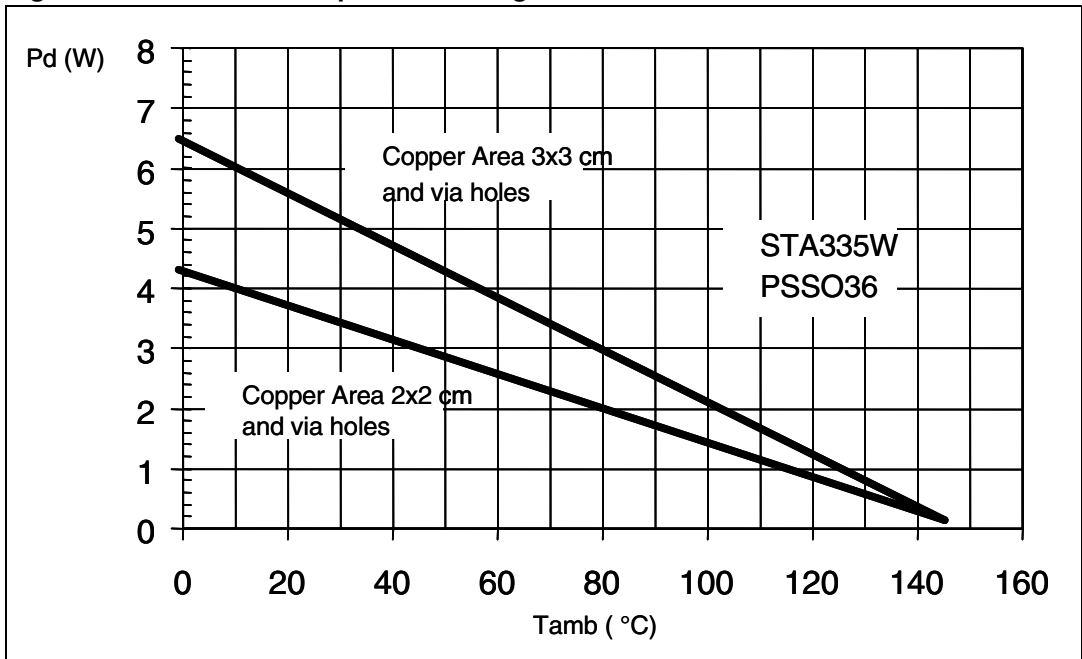

# 8 Package information

Figure 13 shows the package outline and Table 50 gives the dimensions.

Figure 13. PowerSSO-36 slug down outline drawing

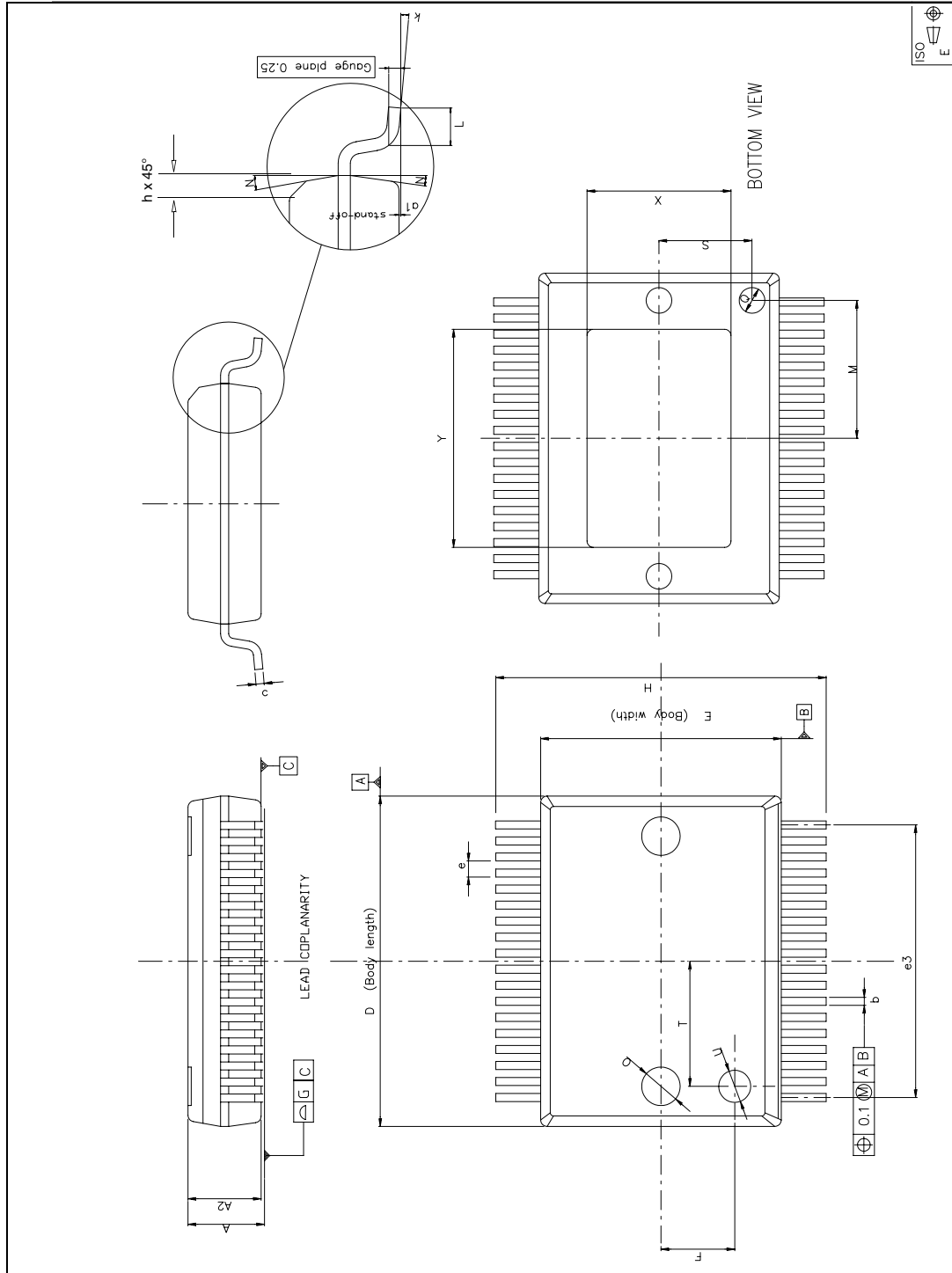



Table 50. PowerSSO-36 slug down dimensions

Symbol	mm			inch		
	Min	Typ	Max	Min	Typ	Max
A	2.15	-	2.47	0.085	-	0.097
A2	2.15	-	2.40	0.085	-	0.094
a1	0	-	0.10	0	-	0.004
b	0.18	-	0.36	0.007	-	0.014
c	0.23	-	0.32	0.009	-	0.013
D	10.10	-	10.50	0.398	-	0.413
E	7.40	-	7.60	0.291	-	0.299
e	-	0.5	-	-	0.020	
e3	-	8.5	-	-	0.335	
F	-	2.3	-	-	0.091	
G	-	-	0.10	-	-	0.004
H	10.10	-	10.50	0.398		0.413
h	-	-	0.40			0.016
k	0	-	8 degrees			8 degrees
L	0.60	-	1.00	0.024		0.039
M	-	4.30	-		0.169	
N	-	-	10 degrees			10 degrees
O	-	1.20	-		0.047	
Q	-	0.80	-		0.031	
S	-	2.90	-		0.114	
T	-	3.65	-		0.144	
U	-	1.00	-		0.039	
X	4.10		4.70	0.161		0.185
Y	4.90		7.10	0.193		0.280

In order to meet environmental requirements, ST offers these devices in different grades of ECOPACK<sup>®</sup> packages, depending on their level of environmental compliance. ECOPACK<sup>®</sup> specifications, grade definitions and product status are available at: [www.st.com](http://www.st.com). ECOPACK<sup>®</sup> is an ST trademark.

## 9 Revision history

**Table 51. Document revision history**

Date	Revision	Changes
03-July-2009	1	Initial release

**Please Read Carefully:**

Information in this document is provided solely in connection with ST products. STMicroelectronics NV and its subsidiaries ("ST") reserve the right to make changes, corrections, modifications or improvements, to this document, and the products and services described herein at any time, without notice.

All ST products are sold pursuant to ST's terms and conditions of sale.

Purchasers are solely responsible for the choice, selection and use of the ST products and services described herein, and ST assumes no liability whatsoever relating to the choice, selection or use of the ST products and services described herein.

No license, express or implied, by estoppel or otherwise, to any intellectual property rights is granted under this document. If any part of this document refers to any third party products or services it shall not be deemed a license grant by ST for the use of such third party products or services, or any intellectual property contained therein or considered as a warranty covering the use in any manner whatsoever of such third party products or services or any intellectual property contained therein.

**UNLESS OTHERWISE SET FORTH IN ST'S TERMS AND CONDITIONS OF SALE ST DISCLAIMS ANY EXPRESS OR IMPLIED WARRANTY WITH RESPECT TO THE USE AND/OR SALE OF ST PRODUCTS INCLUDING WITHOUT LIMITATION IMPLIED WARRANTIES OF MERCHANTABILITY, FITNESS FOR A PARTICULAR PURPOSE (AND THEIR EQUIVALENTS UNDER THE LAWS OF ANY JURISDICTION), OR INFRINGEMENT OF ANY PATENT, COPYRIGHT OR OTHER INTELLECTUAL PROPERTY RIGHT.**

**UNLESS EXPRESSLY APPROVED IN WRITING BY AN AUTHORIZED ST REPRESENTATIVE, ST PRODUCTS ARE NOT RECOMMENDED, AUTHORIZED OR WARRANTED FOR USE IN MILITARY, AIR CRAFT, SPACE, LIFE SAVING, OR LIFE SUSTAINING APPLICATIONS, NOR IN PRODUCTS OR SYSTEMS WHERE FAILURE OR MALFUNCTION MAY RESULT IN PERSONAL INJURY, DEATH, OR SEVERE PROPERTY OR ENVIRONMENTAL DAMAGE. ST PRODUCTS WHICH ARE NOT SPECIFIED AS "AUTOMOTIVE GRADE" MAY ONLY BE USED IN AUTOMOTIVE APPLICATIONS AT USER'S OWN RISK.**

Resale of ST products with provisions different from the statements and/or technical features set forth in this document shall immediately void any warranty granted by ST for the ST product or service described herein and shall not create or extend in any manner whatsoever, any liability of ST.

ST and the ST logo are trademarks or registered trademarks of ST in various countries.

Information in this document supersedes and replaces all information previously supplied.

The ST logo is a registered trademark of STMicroelectronics. All other names are the property of their respective owners.

© 2009 STMicroelectronics - All rights reserved

STMicroelectronics group of companies

Australia - Belgium - Brazil - Canada - China - Czech Republic - Finland - France - Germany - Hong Kong - India - Israel - Italy - Japan - Malaysia - Malta - Morocco - Singapore - Spain - Sweden - Switzerland - United Kingdom - United States of America

[www.st.com](http://www.st.com)

