

THIS DRAWING IS UNPUBLISHED. RELEASED FOR PUBLICATION 2003
 © COPYRIGHT 2003 BY TYCO ELECTRONICS CORPORATION. ALL RIGHTS RESERVED.

LOC	DIST	REVISIONS				
P	LTR	DESCRIPTION	DATE	DWN	APVD	
A1	-	B	EGCO-0021-04	23JAN2004	witt	-

Matrize in Kombination mit Ergocrimp Basishandzange PN 539635-1 verwenden
 Use die in combination with Ergocrimp basis hand tool PN 539635-1

Matrize im Karton mit Bedienungsanleitung 411-18100 verpackt
 Die packed in a cardboard with instruction sheet 411-18100

539682-2	1	5-0744001-5	Instruction Sheet	Bedienungsanleitung	6
	1	0-0519024-2	Nut M4 DIN 985	Mutter M4 DIN 985	5
	1	1-0519151-3	Screw M4x25	Schraube M4x25	4
	1	1-0519151-1	Screw M4x16	Schraube M4x16	3
	1	1-1579015-9	Locator Assembly	Drahtanschlag	2
	1	2-0539786-1	Contact Locator	Kontaktpositionierer	1
	QTY Stck	PN	Description	Benennung	Pos.

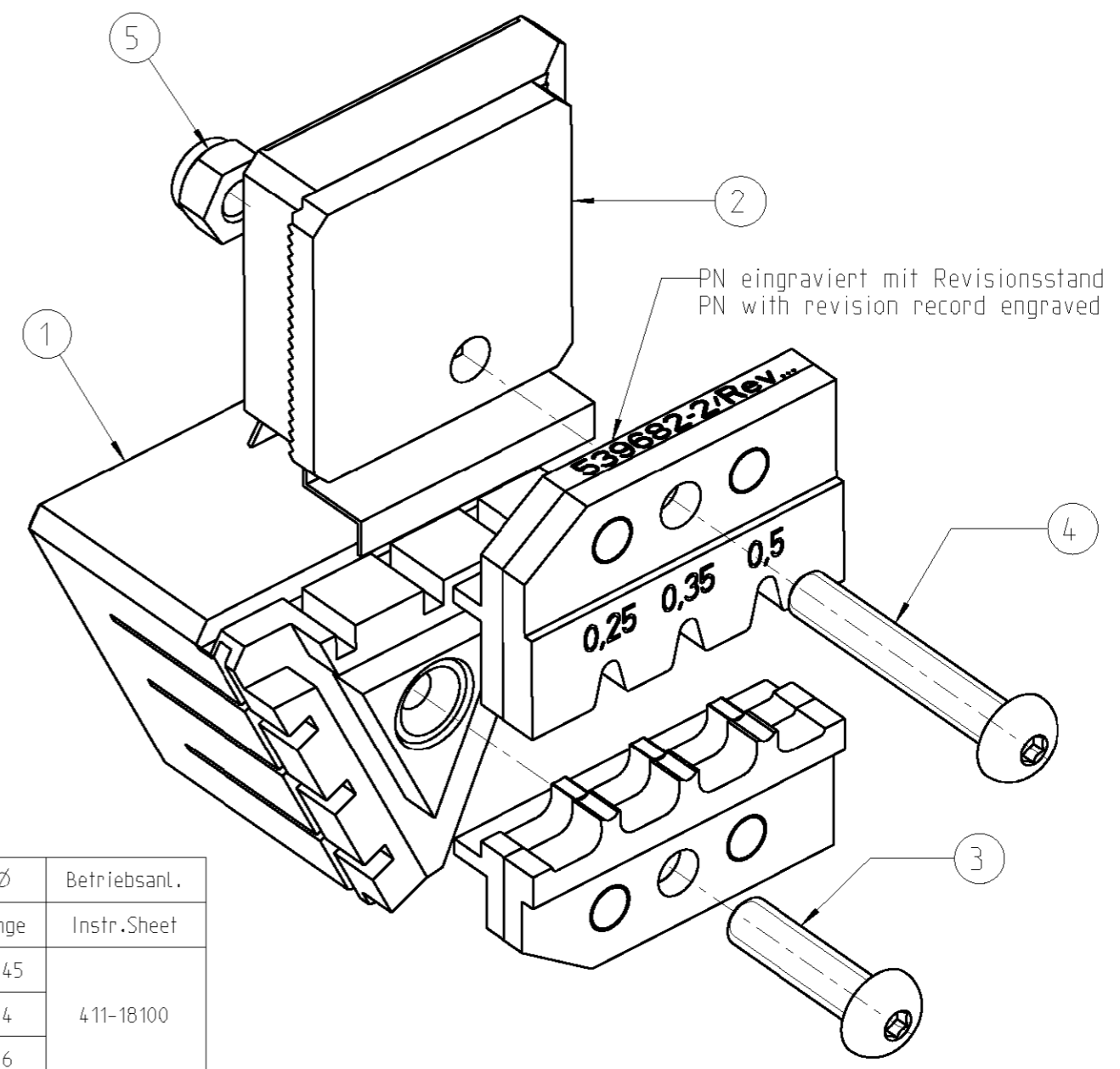

Kontakt	DGB (mm ²)	Drahtcrimp / Wire Crimp		Isolationscrimp/Insulationcrimp		Isol.Ø	Betriebsanl.
Contact	Wire Range	Hoehe/Height mm	Breite/Width mm	Hoehe/Height mm	Breite/Width mm	Ins.Range	Instr.Sheet
963725 / 963726 968220 / 1241919 1355988	0.25	0.72 ±0.03	1.40	1.4 ±0.1	1.83	1.25-1.45	411-18100
	0.35	0.76 ±0.03		1.5 ±0.1		1.2-1.4	
	0.50	0.86 ±0.03		1.8 ±0.1		1.4-1.6	

<small>THIS DRAWING IS A CONTROLLED DOCUMENT FOR TYCO ELECTRONICS CORPORATION IT IS SUBJECT TO CHANGE AND THE CONTROLLING ENGINEERING ORGANIZATION SHOULD BE CONTACTED FOR THE LATEST REVISION.</small>		DWN Ch.Witt 15JAN2004 CHK - APVD - PRODUCT SPEC - APPLICATION SPEC - WEIGHT -	tyco Electronics tyco Electronics AMP GmbH D - 64625 Bensheim
DIMENSIONS: mm 	TOLERANCES UNLESS OTHERWISE SPECIFIED: 0 PLC ± 1 PLC ± 2 PLC ± 3 PLC ± 4 PLC ± ANGLES ±1° MATERIAL - FINISH -	NAME ERGOGRIMP-DIE SET Ergocrimp Matrize	
		SIZE A3 CAGE CODE 00779 DRAWING NO C=539682-2	RESTRICTED TO -
CUSTOMER DRAWING		SCALE 2:1	SHEET 1 OF 1 REV B