

AC axial fan



- **Impeller material:** Sheet steel (welded to the rotor and stove-enameled in black)
- **Housing material:** Die-cast aluminum
- **Bearings:** Ball bearings

Nominal data

Type	Motor	Voltage 1 - VAC	Frequency Hz	Air flow m³/h	Speed 1/min	Power consumption W	Sound pressure level dB(A)	Operative range 50Hz Pa	Ambient temperature 50Hz °C	Weight kg
W2S130BM1501	M2S052CA	115	50	380	2700	47	60	0 .. 125	-25 .. 50	1.1

Subject to modification

Characteristic: Pressure over air flow at 50Hz

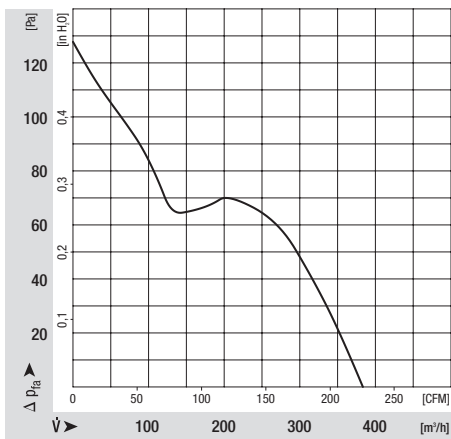

AC axial fan

Specific drawing

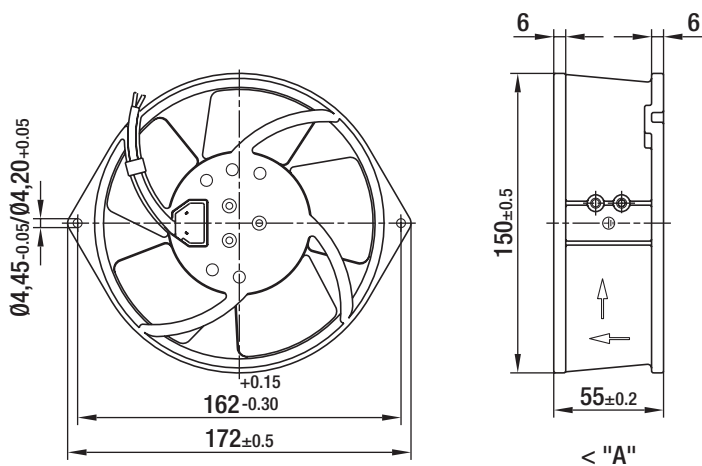

Connection illustration

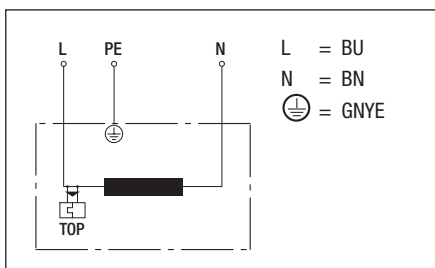

Technical description

- **Impeller material:** Sheet steel (welded to the rotor and stove-enameled in black)
- **Bearings:** Ball bearings
- **Direction of air flow:** "A", intake over braces
- **Operating mode:** S1
- **Protection class:** I
- **Housing material:** Die-cast aluminum
- **Direction of rotation:** Left, looking at rotor
- **Electrical connection:** Cable length 330 mm from wall ring
- **Insulation class:** "B"
- **Approvals:** VDE, CSA, UL

Contact

ebm-papst Mulfingen GmbH & Co. KG
Bachmühle 2
D-74673 Mulfingen
Phone +49 (0) 79 38 / 81-0
Fax +49 (0) 79 38 / 81-110
info1@de.ebmpapst.com
www.ebmpapst.com