



MX1300

Size: D (LR20)

Alkaline-Manganese Dioxide Battery

Zn/MnO₂

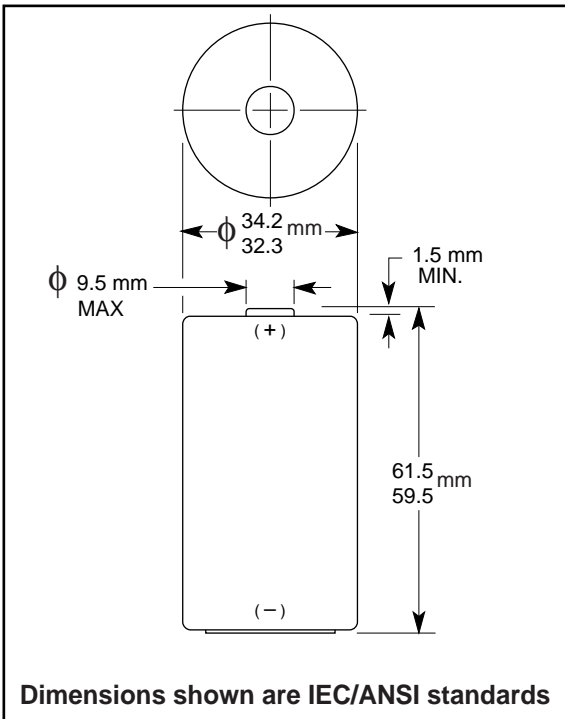

Nominal Voltage:	1.5 V
Nominal Internal Impedance:	126 m-ohm @ 1kHz
Average Weight:	147 gm (5.19 oz.)
Volume:	56.4 cm ³ (3.44 in. ³)
Terminals:	Flat
Operating Temperature Range:	-20°C to 54°C (-4°F to 130°F)
NEDA/ANSI:	13A
IEC:	LR20

Discharge Characteristics at Various Power Drains

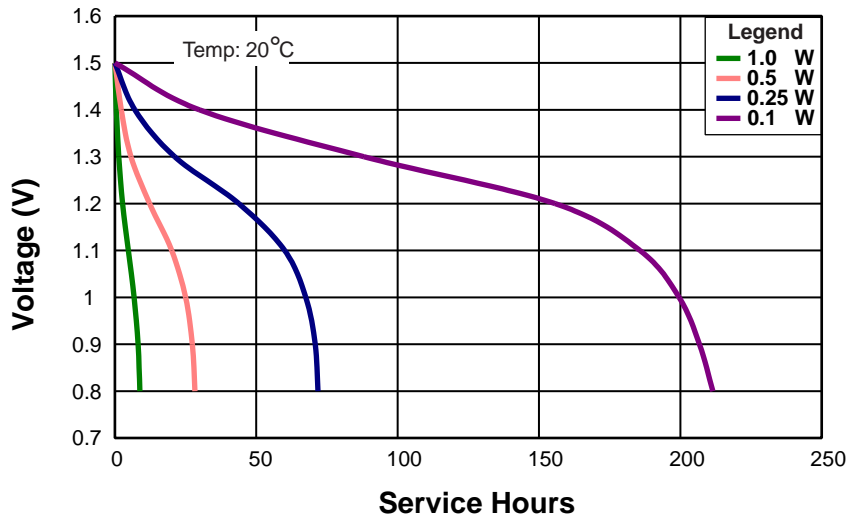

Typical Ultra D Discharge Characteristic

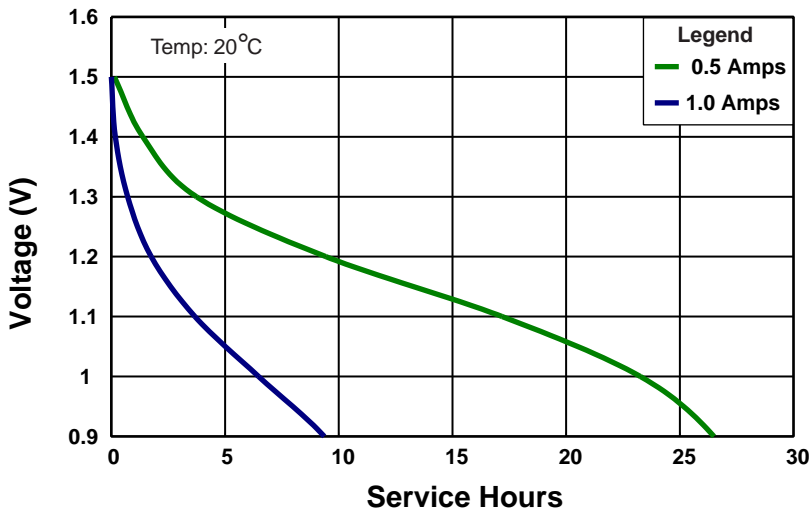

* Delivered capacity is dependent on the applied load, operating temperature and cut-off voltage. Please refer to the charts and discharge data shown for examples of the energy / service life that the battery will provide for various load conditions.



MX1300

Size: D (LR20)

Alkaline-Manganese Dioxide Battery

Zn/MnO₂

Delivered Energy vs Power Drain

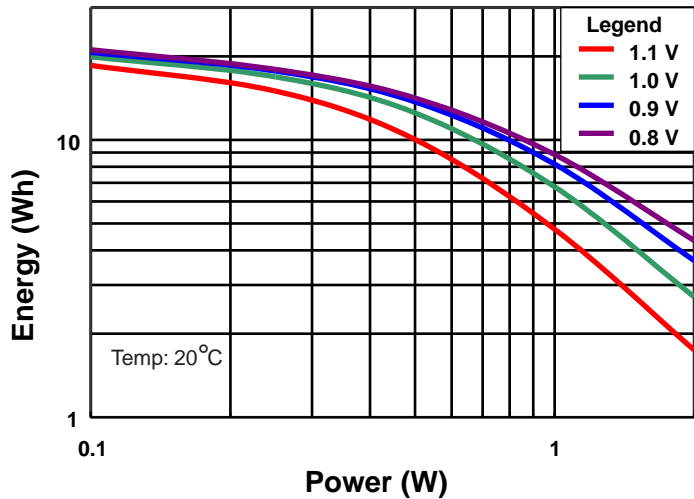

Delivered Capacity vs Power Drain

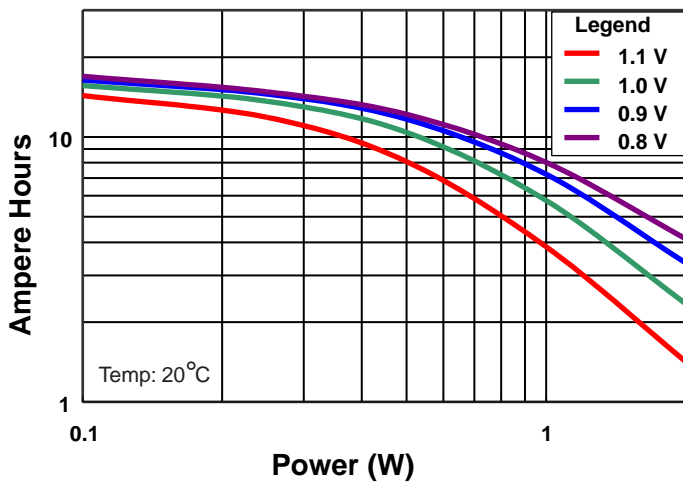

Service Hours vs Power Drain

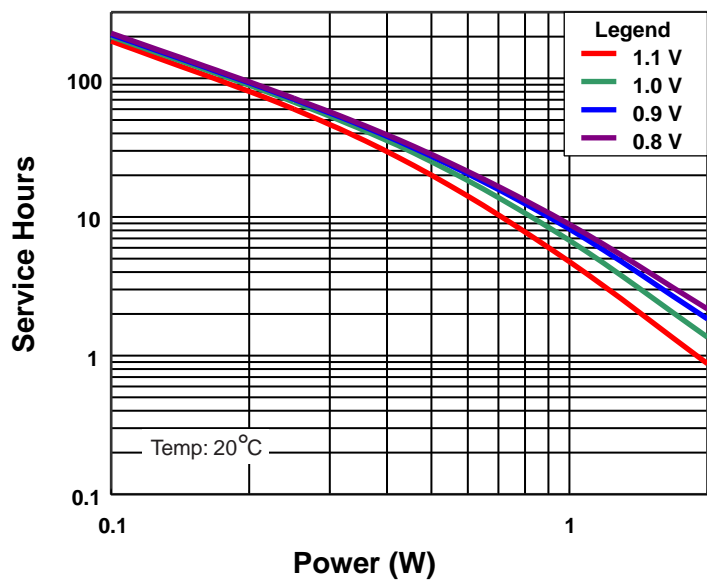

DURACELL[®]
BATTERIES

Berkshire Corporate Park
Bethel, CT 06801 U.S.A.
Telephone: Toll-free 1-800-431-2656
Facsimile: 203-796-4209
Internet: www.duracell.com

* Delivered capacity is dependent on the applied load, operating temperature and cut-off voltage. Please refer to the charts and discharge data shown for examples of the energy / service life that the battery will provide for various load conditions.