

cebekit

WINDLAB JUNIOR C-0200



TECHNICAL CHARACTERISTICS

Power (@ rotor speed 200rpm).....	1W
Output voltage (@ rotor speed 2000 rpm).....	10 V DC
Output current (@ rotor speed 2000 rpm).....	100 mA DC
Output voltage (@ rotor speed 1000 rpm).....	5V DC
Output current (@ rotor speed 1000 rpm).....	50 mA DC
Maximum output voltage of the capacitor.....	6V DC
Output can be switched directly or through the	
Capacitor, charge time (capacitor 0.33F, wind @ 2,23 m/s)...	1minute
The music may sound box.....	30 minutes
LED lamp can illuminate	5 minutes
Start-Up(wind speed indicates the rotation of the rotor.....	1,6m/s(5,6 km/h)
Cut-In(minutes wind speed that generates speed	2,2m/s(8km/h)
Body length of the turbine.....	200 mm.
Radius of the blade sweep.....	155 mm.
Certifications	CE - Rohs
Weight.....	0,6 kg.

CHARACTERISTICS

Kit for people who have some experience in carrying out crafts.

Converts wind energy (wind power) to DC power.

DC output rectified and stored in a super-capacitor (condenser of very high capacity).

Ability to direct output from the generator to evaluate different parameters.

An indicator light (LED) lights up when electricity is being generated.

The generator will automatically aligns vane in the direction of the wind.

The electricity produced can be used to feed external applications (see specific accessories, such as LEDs voltmeter C-0205 and charger C-0204 for mobile phones and rechargeable batteries (must be bought separately).

To learn and raise awareness of environmental conservation, so entertaining, fun and practice

INTRODUCTION

Wind Lab Jr. is a real wind turbine designed for children and young people to experience and learn about energy wind (wind power).

This setup allows us to understand the operation of wind turbines in a practical and manageable. Its shape design kit allows youth to practice their manual skills, something rare today by the hegemony of software. The only tool needed for assembly is a screwdriver star. If you experiment with new blades and vanes, it will require scissors to cut them out This equipment generates electricity even at low wind speeds, it is equipped with a sensitive and powerful engine.

This equipment generates electricity even at low wind speeds, it is equipped with a sensitive and powerful engine phase. Can be used directly in the wind or from any artificial source of forced air, as a fan powerful. This allows you to experience both the turbine and electrical applications whatever the weather situation and climate, even within an enclosed space like a classroom.

The alternating current generated is rectified and sent to the output in two ways:

directly or through a super-high capacity condenser.

To conduct various experiments and evaluations, the team includes the module C-206 mail, music box functions, fixed and LED flashing LED. Connect the RED and BLACK RED module terminals (+ EV) and BLACK (GND) of the wind turbine output connector and observe the results.

The LED is inside the main body of the turbine is illuminated when generates electricity. The turbine vane automatically aligned in the direction wind. The voltage to LEDs C-0205 (not included) is the ideal complement to experiment with the wind turbine.

external power module

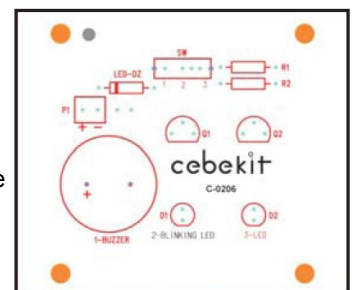

A wind turbine is an electrical generator driven by a turbine powered by wind (wind turbine). The wind energy, in fact the kinetic energy of wind, provides mechanical energy to the rotor blades helix. The rotor, through a mechanical transmission system, spins a generator (usually a three-phase alternator) that converts mechanical energy into electrical energy.

The direct predecessors of the current wind turbines are the windmills that were used in grinding grain for flour production (as the old windmills of Europe).

The first big windmill designed as automatic electricity generator on record, was built during the winter of 1887-88 by Charles F. Brush in Cleveland (Ohio). Generated 12kW of electricity, had a rotor diameter of 17 m and 144 blades constructed of cedar wood. It worked for 20. Its yield was low because the rotor spinning at low speed.

The Dane Poul La Cour found that fast rotating wind turbines with fewer blades and rotor are efficient electricity production that slow turning.

There are many types of wind turbine be categorized in many different ways: according to the position of the axis (Horizontal or vertical), depending on the type of generator, as the power level, etc.

Currently there are mini-wind turbines, which produce from several tens of watts to kilowatts used in isolated power systems (Where there is no power lines): vessels, homes private, electronic equipment, relay stations or streetlights. Large modern wind turbines rotors may have from 40 to nearly 100 meter diameter, which can produce up to several Megawatt Power (1 MW = 1.000.000 W).

Wind turbines, like solar photovoltaic systems can operate singly or grouped forming large wind farms. They tend to settle more or less distant from each other, according to the turbulence that may cause the movement of its blades and even in terms of environmental impact.

The use of wind energy is, at present, the technology of energy production more growth in the world having shown its industrial viability. Currently energy production by wind only covers a small percentage of our total energy consumption, but their level of growth leaves provide a promising future and will occupy an important part of our energy consumption the future. Learn today about a green energy future.

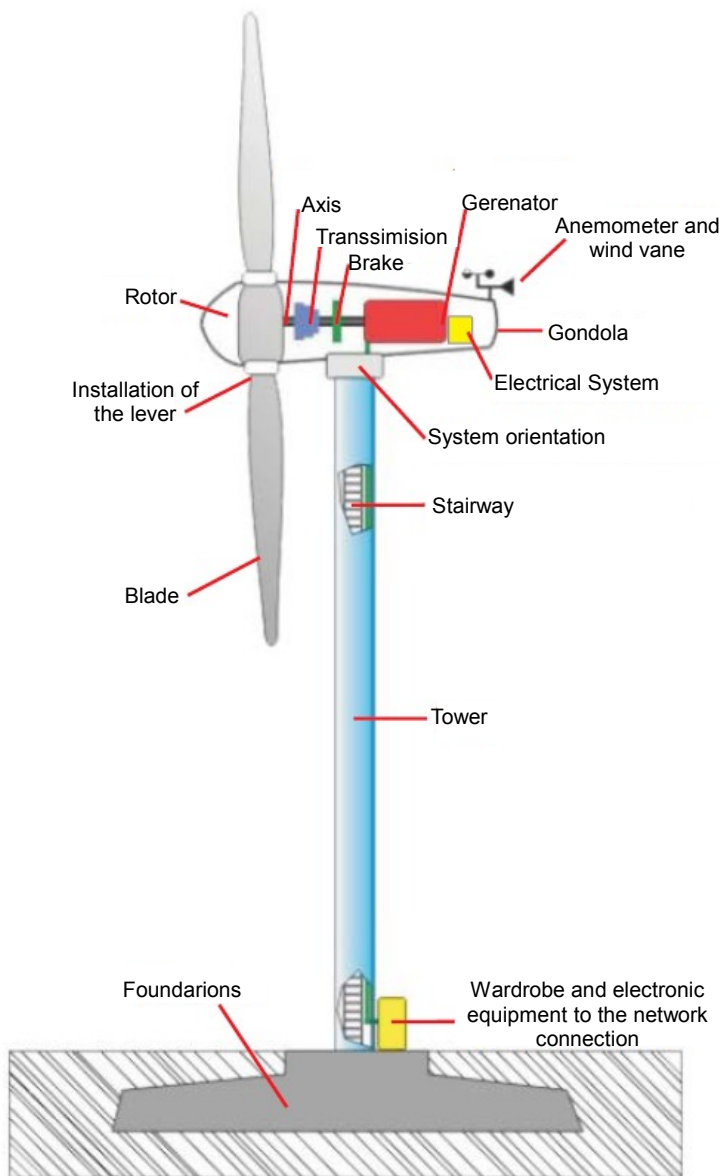

Schematic of a turbine type

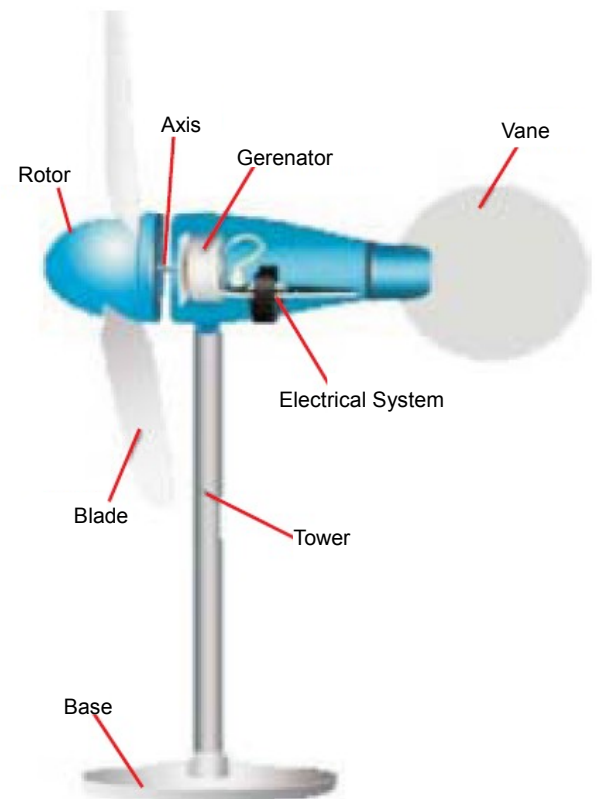

Scheme C-0200 wind turbine

OPERATION

The Junior Wind lab works in two modes: Normal and staging. Two small switches (Normal / Live and 0 / 1) for selecting the output current connector

Nomal Mode

If we select the switch S2 in normal mode, the electricity generated is stored in the Super-capacitor. According to the switch S1 is selected in "1" or "0" (ON or OFF). power will be transferred or stored to the output connector .

Direct Mode

If we select the switch S2 in Direct Mode, the electricity generated will be transferred to the output connector if the switch S1 is in position "0." The output of the generator is ready for us to assess the various parameters of wind energy. Among them, the relationship between wind speed and rotor speed, the influence of the shape and size of the blades in relation to electricity, etc.

You can also use the generator directly to power their own applications and even to store the energy generated externally, such as through the charger C-0204 (*), for telephones, mobile and rechargeable batteries.

If S1 is "1", the output connector is connected to the super-capacitor. Then we use the energiaalmacenada, but the energy that can now be generated or stored, or sent to the output.

You can connect several turbines in parallel C-0200 to have its own wind farm and get more power available for its practical applications

Function switches

		S2	
		Normal	Direct
S1	0 OFF	When the generator produces power electric super-capacitor load. The output is disconnected	The generator is connected directly to the output connector. Super-capacitor is not either the generator or connected to the output
	1 ON	When the generator produces power electric super-capacitor load. The output is connected to the generator and the super-capacitor	The generator does not charge the supercapacitors. The Super-capacitor is connected to exit

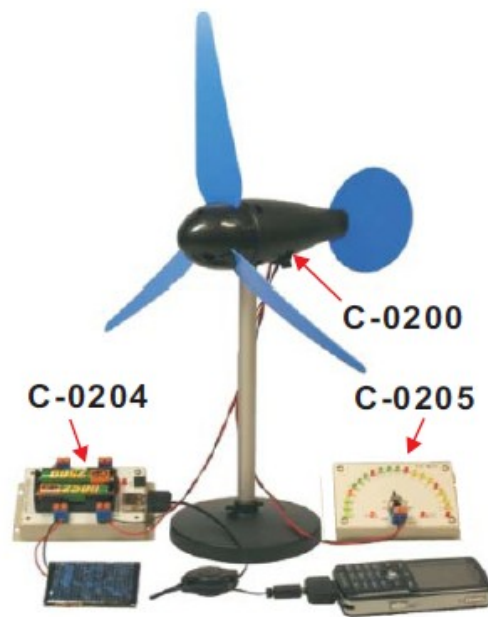

The voltage to Leds C-0205 (*) is the ideal complement to experiment and evaluate wind turbine voltage, checking in real time the relationship between speed the wind and the tension generated.

(*) **Note.** Accessories C-0204 and C-0205 be purchased separately.

Internal electronic circuit of Junior Lab Wind:

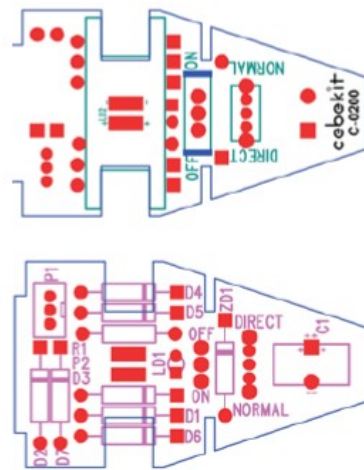
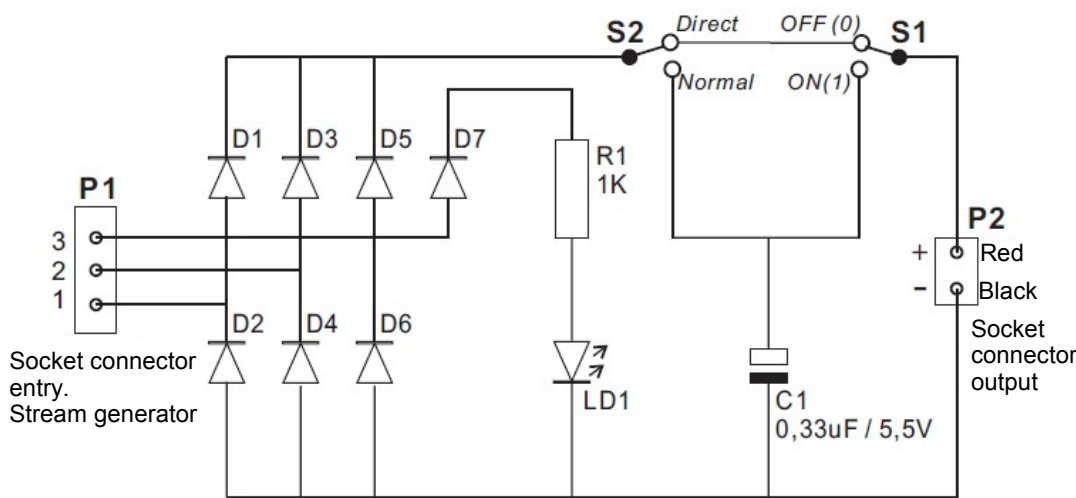

Blades and vane

Junior Lab The Wind is equipped with a set of six blades and a vane. These are cut from a sheet of plastic flexible (Polypropylene). The concept of Junior Lab Wind is that everyone can design their own shovels and plastic vanes or blades normal card. You can change the number of blades, size and profile of them, to see what happens to the electricity generated in the form and the number of blades. In the same way you can modify the size, shape and color of the vane. Try your own designs, bold and fun. In Annexes II and III (pages 10 and 11) are some templates.

Instructions

First you must identify those parts to be used in the construction of wind turbines. Then follow assembly directions step by step

N°	Piece	N°	Piece
1	Left side of the housing	10	Phase generator
2	Right side of the housing	11	Electronic circuit assembly
3	Rotor head	12	Flat spring, inserted at the base of the blades
4	Base of the blades	13	Screws M2, 6 x 10mm (closed shell)
5	Base ballast	14	Screws M2, 6 x 18mm (Cover fixing rotor)
6	Pin	15	Screw M3 x 2mm (stop motion)
7	Aluminum tube	16	Nut M2, 6
8	Polypropylene Blades	17	Self-tapping screws (ballast base)
9	Polypropylene Veleta		

Main body assembly

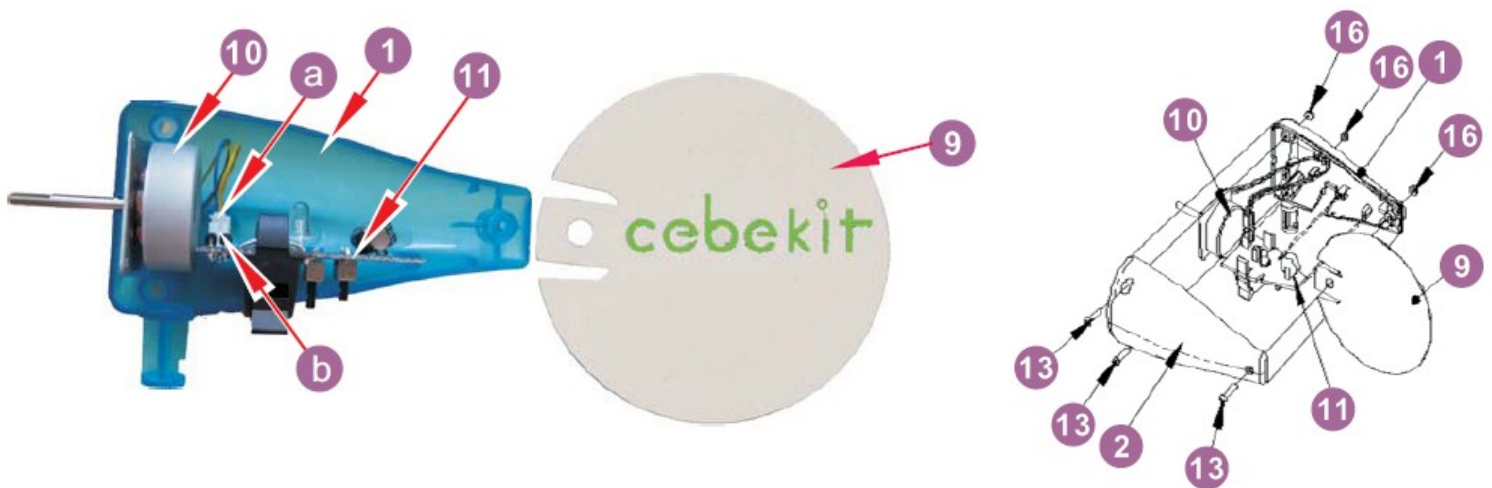

- 1.1 Plug connector (a) of the generator (10) to the socket (b) the electronic circuit (11).
- 1.2 Install the generator (10) into the slots of the housing left (1), push to make sure you have reached the end
- 1.3 Place the electronic circuit (11) and vane (9).
- 1.4 Closing the set covering the other half of the turbine casing (2).

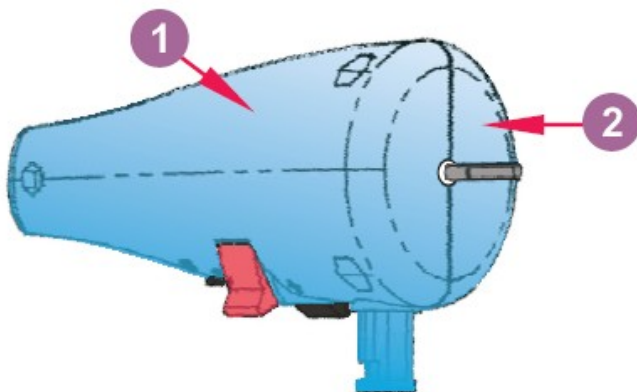

Verify that the generator shaft is well focused on the drill casing. Otherwise open and rectify the position of the generator.

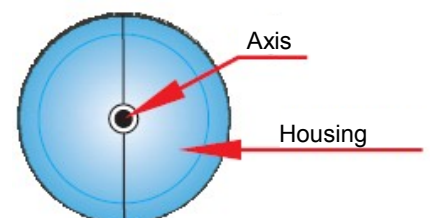

- 1.5 Set the set screw (13) and nuts (16), as shown in the drawing.

First you must enter the 3 nuts (16) on the left side of the casing (1). You can help with a long screw (14) to insert to the bottom.

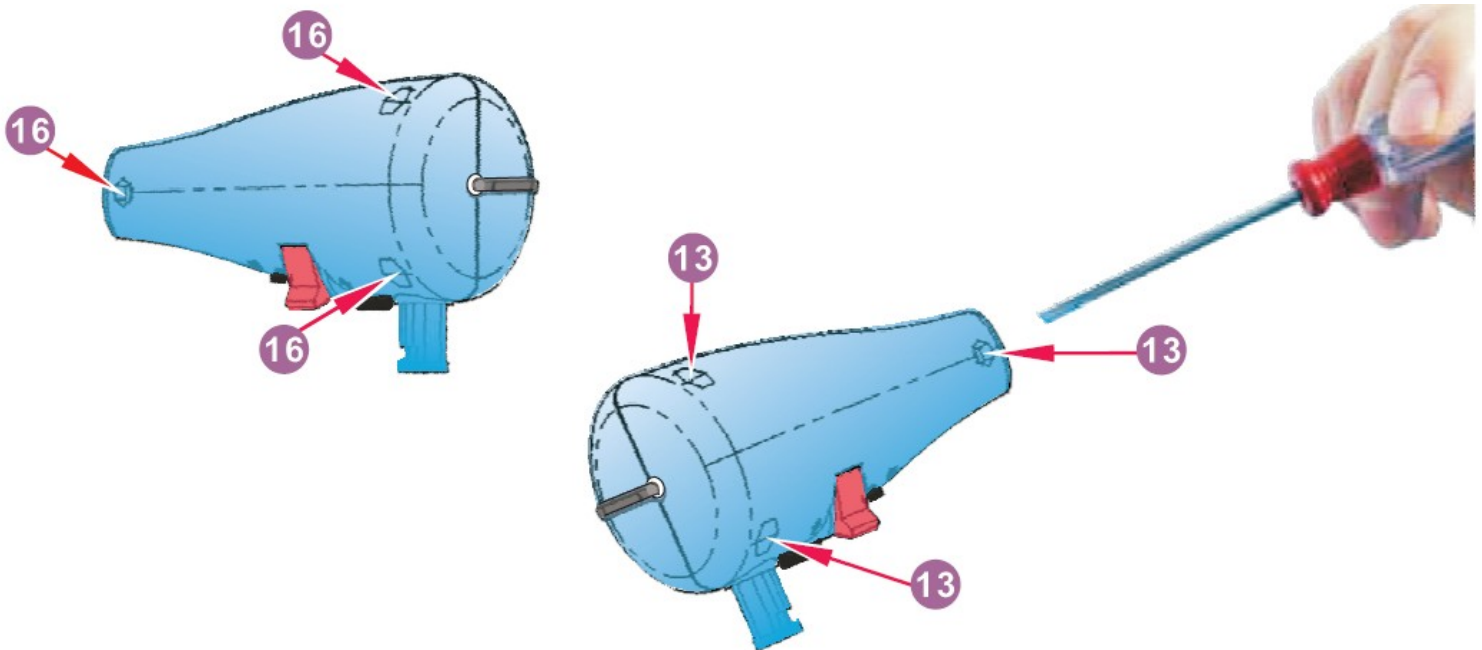

Installation instructions

2. Mounting the rotor (set of blades)

2.1 Insert three screws (16) in alternate habitats (one other, other does not) for albegar nuts. If temporarily screwed the nuts with a screw (14) force they are nailed to their living quarters. Then remove the screws (14).



2.2 Now install the blades at the base of the rotor. Take the base of the blades (4). Verify that the flat spring (12) is positioned as shown. Note that the blades are not symmetrical. If installed with the side wrong, they touch the aluminum mast when turning. Look closely at the correct position shown. If you mount three blades (8), place them in alternative habitats (one yes, another not) at the base of the blades (4).

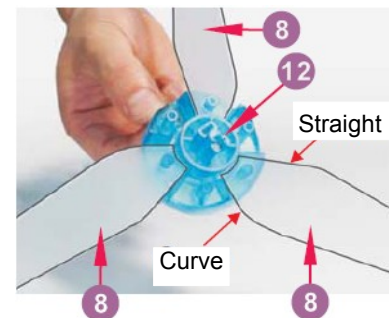

2.3 Now cover the whole base and blades with the rotor head (3). Check the position of head of so that the holes for the screws, match the holes in the base with a nut (16) is inserted. Otherwise rectify the position



2.4 Secure with the three screws (14). Before screwing make sure they are aligned with their corresponding nuts (16). Tighten with a suitable screwdriver.



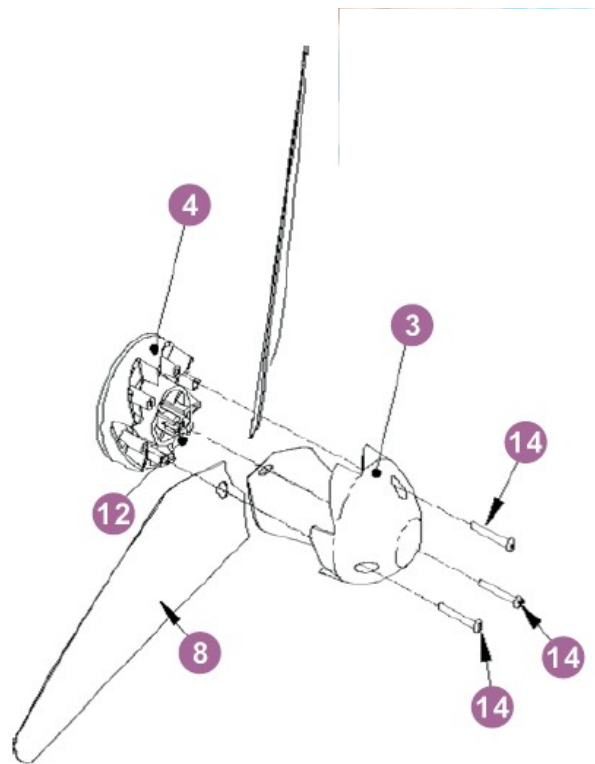
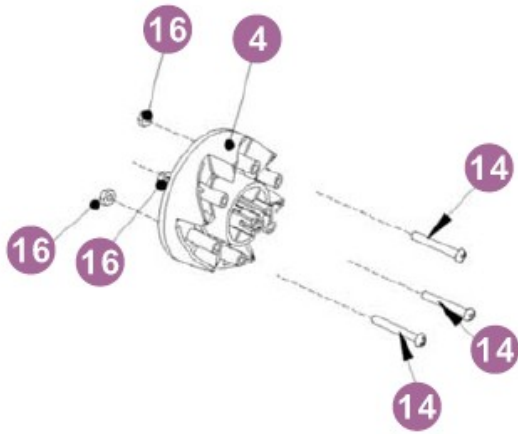

3. Installation of the rotor in the main body

- 3.1 Insert the rotor assembly with blades (mounted in point 2) in the generator shaft main body, which has mounted in 1. Tighten up the bottom.

Make sure the group tighten the rotor shaft. Check the rotor has been firmly fixed to the turbine shaft and can rotate freely.

If you prefer, you can install a set of rotor blades after having the main body mounted on the pole and the base.

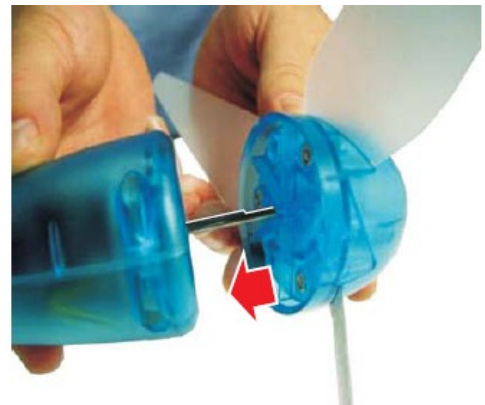

4. Mast assembly and final assembly

- 4.1 With self-tapping screws (17) attach the metal ballast part lower penalty (5).
- 4.2 Install the aluminum tube (7) in the base (5).
- 4.3 Secure with pin (6).

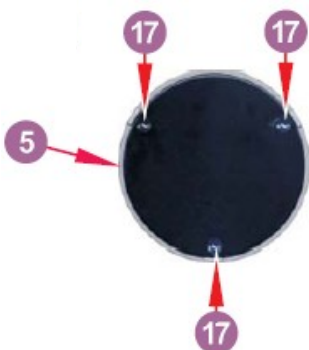

4.4 Insert the assembly of the turbine at the top of the aluminum tube

Check that the turbine inserted into the post, may vary slightly when the wind pushes the vane. Otherwise do rock with the hand. Remove and reinsert it two or three times. Clean any filings aluminum inner tube, are remnants of machining the ends. If necessary, repeat the process to ensure the free rotation of the turbine in post.

4.5 Insure now with a screw (15). This screw will limit the almost 350 ° spin preventing complete turn around, so that the cables are not crimped the tube (7) and booting.



ATTENTION

To prevent accidents, should keep hands and body away from the blades when they are spinning. A gust of wind can make vane causes the sudden twist generator. Stay away adequate to prevent damage.

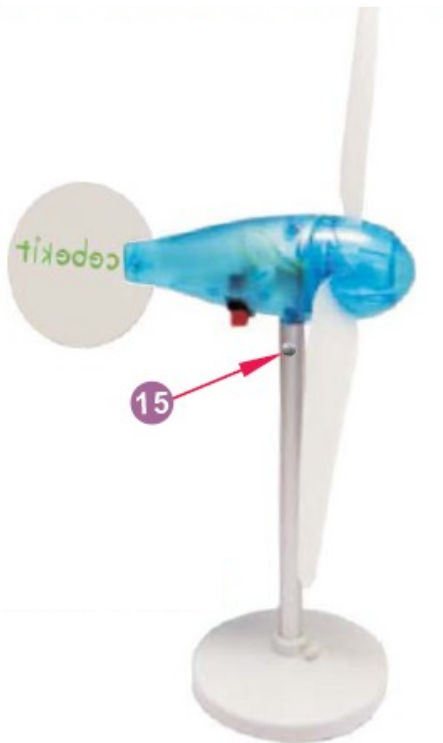

¡The Wind Lab Jr. is ready to capture the energy of the wind!

Frequently Asked Questions (F.A.Q.)

1 - ¿What is the maximum power that can develop the Wind Lab Junior?

Maximum output capacity three-phase AC generator is 2.25 W, a maximum speed of the rotor 3000 rpm. If the wind speed and the design of the plates allow Junior Lab Wind rotor speed reaches 3,000 rpm, the output current (DC). can be 15V / 0.15A (2.25 W)

2 - ¿What is the range of DC output voltages of Junior Lab Wind?

The voltage is proportional to the rotational speed of the rotor. The DC output voltage of Junior Lab's Wind around 5V, 10V and 15V, corresponding to rotor speeds of 1000, 2000 and 3000 rpm, respectively. These stresses are averages, the maximum stresses can be 7V, 14V and 21V respectively.

3 - ¿Why Wind Junior Lab uses a three-phase alternating current (AC) instead of a generator of current (CC)?

A DC generator has a switch (collector) that comes into contact with carbon brushes for remove the power. For the three-phase AC electric current is extracted directly from the three coils that are connected to external circuits. In a three-phase AC generator is no mechanical contact parts are worn. The life of an AC three-phase is much longer than the a DC generator, however, the voltage output from a three-phase AC needs to be corrected to convert direct current for storage.

4 - ¿Why the sound of music is strange when the music module is connected to the Wind Lab Jr. in "LIVE"?

In direct mode the output current is continuous, but with some ripple (ripple) current AC. No capacitor to filter the AC ripple as in NORMAL mode. When the current of the DC source that feeds the music module contains a ripple level CA significant, the output of music contain this component of the AC ripple that makes not sound like music should sound

5 - ¿Why Most wind generators are three-bladed?

The energy generated by a windmill is proportional to the area swept by the blades. Does not depend on number of them. A high speed of a strong wind, the paddle becomes a wall that obstructs the passage of wind. That is, when wind speed is quite high, a shovel is enough to allow the rotor spinning at a speed close to its maximum. Nevertheless, with a single rotor blade work unbalanced need a counterbalance. A two-blade design is very common, however, the generator can cost initiate the turn with weak winds. The three-blade design is the most common because the generator can rotate easily and is the smallest number of blades so as to achieve a good performance

6 - ¿How I can get the output voltage of the DC stable Junior WindLab?

You can connect an external capacitor on the output terminals. Note the correct polarity

7 - ¿I can change the super-capacitor Junior Lab Wind by another of higher capacity?

Indeed, it may replace the super-capacitor (also known as Gold-Capacitor) buying in a shop of electronic components higher-capacity one (eg .47 uF / 5,5 V or 1F / 5,5 V and change in the printed circuit. However, you must have a proper soldering and knowledge and enough experience to do so without damaging the circuit.

8 - ¿How I can make my own weather vane and blade?

You can use the drawings of Annexes I and II as templates to cut their own shovels. Photocopy or trace the design on a card or, better yet, on a sheet of plastic, and then prune them with scissors. If your town does not find plastic sheets, you can use a folder covered with plastic, which are usually of polypropylene. Try different colors or materials for blades and vane blades and can even make drawings on them. You can test different combinations and with 2, 3 and 6 blades.

9 - ¿What precautions should I take in making my own blades?

Blade must be designed so that its tip is close to the rotor head. This will increase the distance between the edge of the blade and the post. If not, the blades can touch the post when wind speed is high. The flexible plastic sheets are deformed when the velocity of the wind is strong.

10 - ¿How I can install the Wind Lab Jr. in the roof of my house?

You need a long pole which can be fixed strongly carrying the kit. You must set the wires to the pole with plastic ties or clamps.

11 - ¿I can use the Junior Lab Wind to charge the rechargeable batteries?

Yes, you can use the Junior Lab Wind to charge rechargeable batteries. The time required for charge them fully dependent on wind energy. It is necessary to ensure that batteries are not charged excessively. You can purchase the C-0204 adapter that allows you to charge your mobile phone and rechargeable batteries, both AA and AAA size.

Annex I: Some physical concepts about wind energy and wind turbines

WIND

All renewable energy (except geothermal), derived ultimately from the sun. About 2% of the power that the earth receives from the sun is converted into wind energy. The wind is generated as a result of differences temperature reached by different parts of the earth, due to their difference in altitude (mountain and valley winds, rising air currents generated in hours of sun and down at night), the latitude, or the difference soil temperature and sea water. In the latter case are breezes ranging from land to sea during the C-0212 Wind and Weather. Wind is a completely renewable energy source. While the sun shines, the winds blow.

This will not pollute our air and water, or waste produced each year is stacked. We can continue using a wind turbine efficiently and effectively for centuries, without worrying about how it will affect future generations.

The use of wind energy (called wind energy) is at present the production technology energy mundo. Actualmente fastest growing energy production by wind only covers a small percentage of our total energy consumption, but its growth rate leaves provide a promising future and will cover a important part of our energy consumption in the future. The advantages of energy from wind are numerous. hours of sunshine, and from sea to land at night. To learn more about the formation of wind and other phenomena weather, we recommend our education kit

¡ Wind energy is FREE !

¡ If not used, is wasted !

Laws of physics concerning wind energy.

First law: The power available in wind is proportional to the cube of wind speed.

This means that if wind speed doubles, for example, if you switch from 2.5 to 5 m / s, the force available in the helices multiplied by a factor of eight. Even small increases in wind speed result in large amounts of force. An increase in wind speed from 4.5 to 5 m / s lead to an increase of 33% of force in the propellers. It also means that if the wind speed decreases by half, decrease the power generated to the eighth. In the If winds remember to use a big fan of sitting in the experiments.

Second law: The force available in the blades is proportional to the square of the diameter of the rotor.

In other words, if you double the diameter of the rotor blades making twice as long, the force is multiplied by four

THE FORMULA

Electric Power Wind Energy Generator (Wind Turbine)

$$P = 0,5 * \rho * S * v^3$$

as the rotor swept area $S = \Pi * r^2$, we can write

$$P = 0,5 * \rho * \Pi * r^2 * v^3$$

P : Power in watt (W)

ρ : Density of dry air at sea level and 15 ° C: 1.225 kg/m³

s : The area swept by the blades of wind turbine

r : Rotor radius in m

v : Wind speed in m / s

The important thing is to understand that a small difference in wind speed can make a big difference in available energy and in electricity produced, and therefore a big difference in the cost of electricity. Also, when wind speeds are low it can get very little energy. Winds of 2.7 m / s contain less than one eighth of the energy that the wind of 5.4 m / s.

BETZ LAW

Albert Betz was a German physicist, pioneer in wind turbines. Betz's Law, formulated in 1919, said that a wind turbine can only convert into mechanical energy less than 16/27 (59%) of the kinetic energy of wind

Wind energy is a variable resource

It is only electricity when the wind blows. The force of the wind changes throughout the day. Varying according to time throughout the day according to the seasons, according to the heights, etc.

One can experience this by flying a kite. When the wind blows along the ground loose, it is difficult to make it fly. Without But when it gets sent to a certain height, you can stay there for long. This shows that wind speed is above the higher you are on the ground level. So wind power generators in general, is mounted on a tall tower.

Design of propeller blades

Another very important parameter for wind power generator is the propeller blade, and it is the party turns the rotor.

To design a wind turbine that can produce electricity at low wind speed:

The propeller blade should be long.

The propeller blade should be wide.

It should have enough shovels.

If you want to get more power when the wind blow gently propellers can be designed twice as large necessary, however, there may be times when the wind blows violently. If the whole of wind turbine is not designed to withstand these blades as large during a violent storm, the entire system can be destroyed. If it were a machine as heavy as an automobile engine, mounted high and turning several hundred revolutions per minute, in case of destruction would cause a disaster.

Therefore, the propeller blades must be designed so that, within the range of wind speeds in the area, the rotor turns most of the time at maximum speed and the whole of the wind generator is sufficiently strength to withstand the strong winds expected. A wind power generator subjected to large wind very fast laps can not efficiently if the surface of the blade is too large. The large blade area then becomes a wall. This wall can fly or you can make the rotor spin at a speed higher than it can bear. However, as the WindLab Junior C-0200 is small, the surface of the propeller blades helix is important to collect wind energy. Therefore, for a short blade, it takes more surface compensate for the short length and be able to collect enough energy from the wind.

The propeller blades should be well balanced to prevent vibration. When the wind blows at a speed very high, the ideal number of blades is only ONE. However, this would cause an imbalance, therefore requires a counterweight. It is also quite common with TWO blades design, however, the generator can be difficult to start spinning at some critical moment. A three-bladed design is usually used because the generator can start up easily and is the smallest number of blades to achieve good performance.

WIND SPEED

The wind turbine output voltage is proportional to wind speed. Requires a minimum wind speed (Speed Start or Start-up Speed) to the generator rotor to start spinning. It requires a higher wind speed (Cut-in Speed) for the generator starts to supply electricity for the exit.

A generator is specifically designed to produce electricity at its maximum efficiency, only a certain range wind speed, ie the rotor rotates close to the maximum speed that accepts the generator. However, a too windy damage the turbine.

At different times of year in different parts of the world, the wind speed is considerably different. A wind power generator can be very efficient at one time, rather than in the past. To maximize the amount of electricity from wind power generator, the parameters of the propellers should be modified.

In general, large generators, the larger the blade area greater ease of generator begin to rotate. But this big shovel prevent the generator rotate at high speed when the wind is stronger. Pallas long and narrow to allow the generator rotate faster when the wind blows stronger.

ROLE OF VANE

The vane allows the wind generator geared directly into the wind. When the wind blows from side pushes the vane until it is aligned in the same direction of wind. Then the wind power generator also be faced in the direction of the wind. This type of wind turbines are called "Abarlovento" O "Aproa"

Annex II: Template for their own shovels.

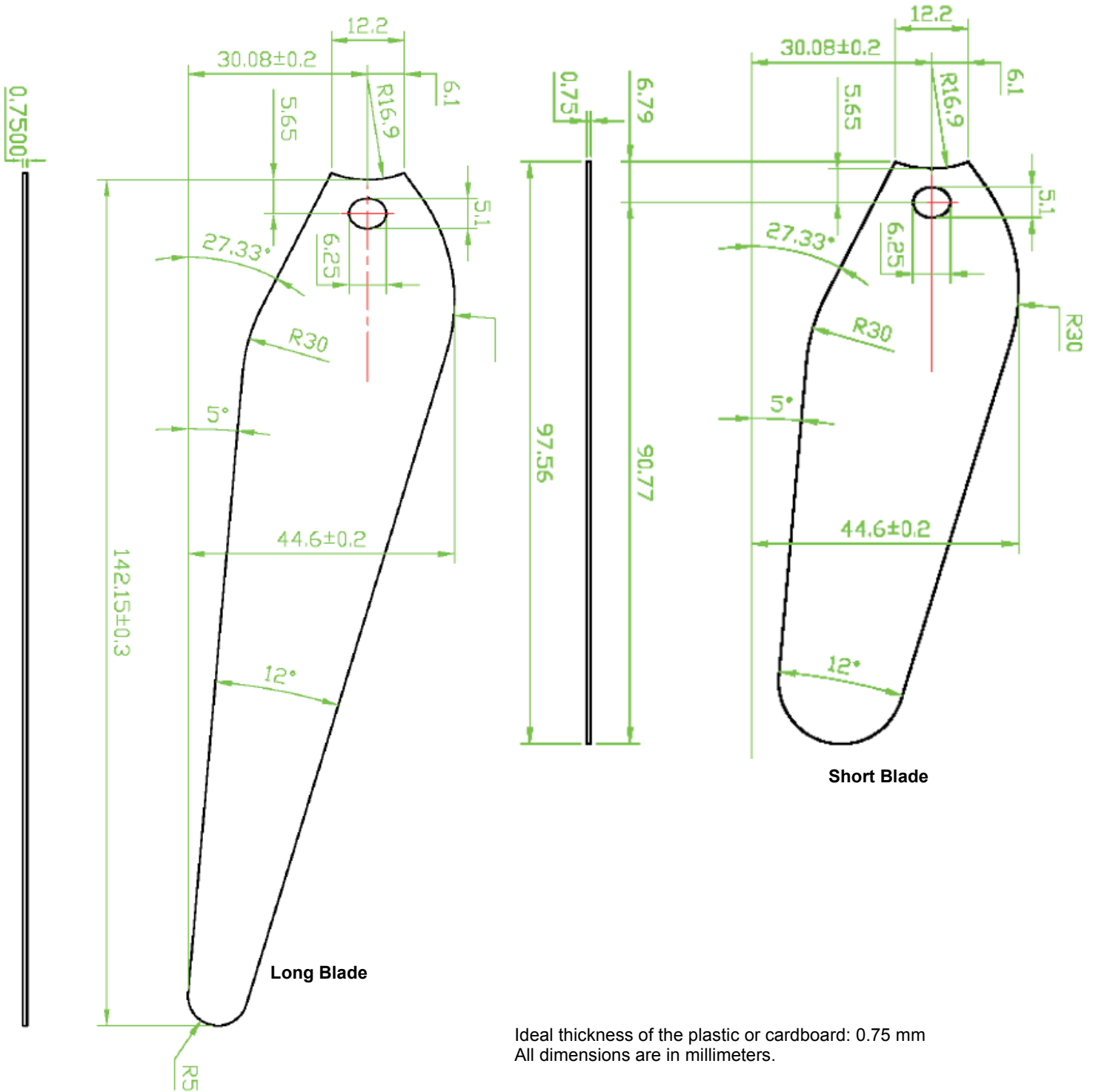

Ideal thickness of the plastic or cardboard: 0.75 mm
All dimensions are in millimeters.

Annex III: Template for your own weather vanes.

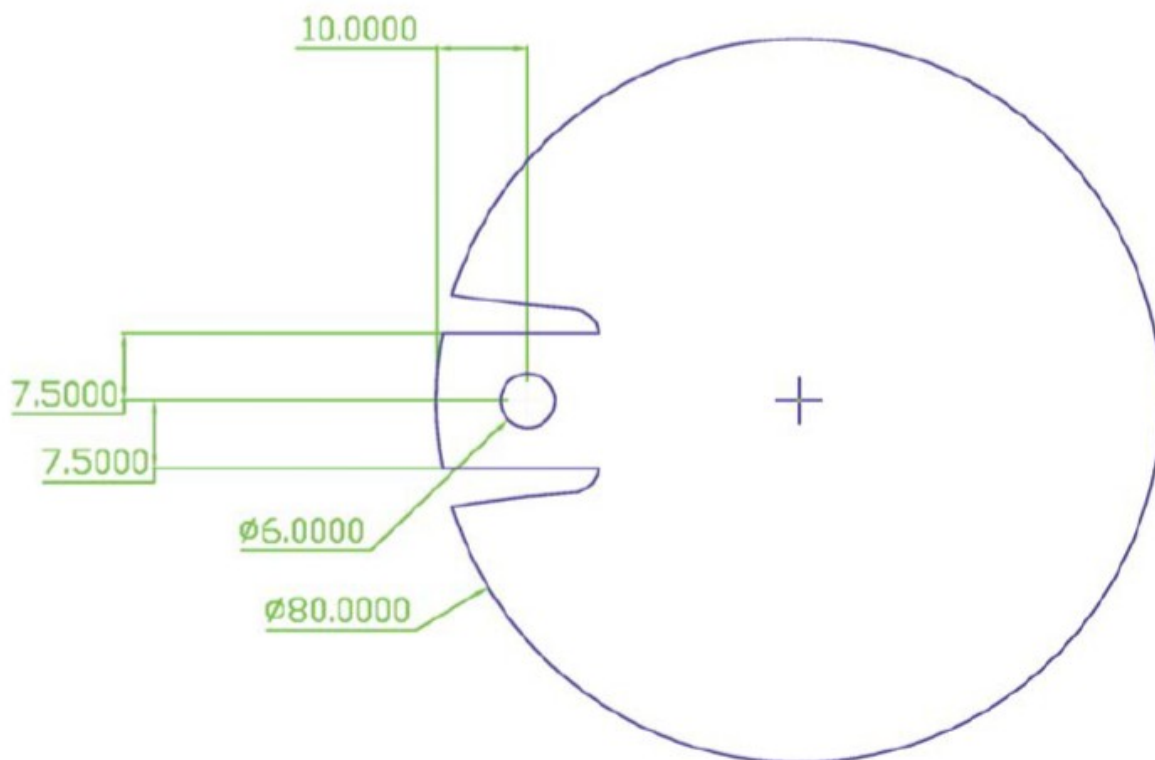

Ideal thickness of plastic or cardboard: 0.75 mm and 1 mm
All dimensions are in millimeters.

NOTE: This kit is recommended for children aged 14 years, always accompanied by an adult

