

LM5030 Evaluation Board

National Semiconductor
Application Note 1305
Dennis Morgan
January 2004



Introduction

The LM5030EVAL evaluation board provides the design engineer with a fully functional push-pull power converter using the LM5030 PWM controller. The performance of the board is as follows:

- Input range: 36V to 75V
- Output voltage: 3.3V
- Output current: 0 to 10A
- Measured efficiency: 82% (at 48V in, 10A Load Current)
- Board size: 2.4 x 2.4 x 0.5 inches
- Load regulation: $\pm 1.0\%$ (1 - 10A)
- Line regulation: $\pm 0.15\%$ (36 - 75V)
- Shutdown input
- Synchronizing input

The printed circuit board consists of 2 layers of 2 ounce copper on FR4 material, with a total thickness of 0.062 inches. The board is designed for continuous operation at rated load.

Theory Of Operation

Referring to *Figure 7*, the LM5030 controller (U1) alternately drives two N channel MOSFETs, which feed the two halves of the power transformer's primary (T1). The transformer's secondary is rectified, and filtered with an LC filter (L2, C3-5), to provide the output voltage. The feedback path starts with the LM3411 precision regulator driver (U3) which senses the output voltage, compares it to its internal reference, and drives an optocoupler (U2) based on the error voltage. The optocoupler provides isolation in the feedback path, and its open collector output drives the COMP pin on the LM5030, which controls the pulse width to the MOSFETs. The lower the voltage at the COMP pin, the smaller the MOSFET duty cycle.

Current in the main transformer's primary is monitored at the LM5030's CS pin via a current sense transformer (T2). The voltage at the CS pin is used for current mode PWM control and current limit protection.

The output inductor (L2) not only smoothes the output voltage waveform, but also generates an auxiliary voltage (by means of its secondary winding) to power the Vcc pin on the LM5030. This feature reduces power dissipation within the IC, thereby increasing reliability.

A Synchronizing input pad (SYNC) is provided on the board to synchronize the circuit's operating frequency to an external source. A Shutdown input pad (SD) permits shutting down the circuit's operation from an external switch to ground.

Board Layout and Probing

The pictorial in *Figure 1* shows the placement of the significant components which may be probed in evaluating the circuit's operation. The following should be kept in mind when using scope or meter probes:

1. The board has two circuit grounds - one associated with the input power, and one associated with the output power. The grounds are capacitively coupled (C6), but are DC isolated.
2. The main current carrying components (L1, T1, T2, Q1, Q2, D1 and L2) will be hot to the touch at maximum load current. USE CAUTION. If operating at maximum load current for extended periods, the use of a fan to provide forced air flow is recommended.
3. Use care when probing the primary side at maximum input voltage. 75 volts is enough to produce shocks and sparks.
4. At maximum load current (10A), the wire size, and length, used to connect the board's output to the load becomes important. Ensure there is not a significant voltage drop in the wires. Note that two connectors are provided at the output - one for the +3.3V output (J2 Out), and one for the Ground connection (J3 IGND). It is advisable to make good use of this feature to ensure a low loss connection.
5. The input voltage connector is J1.

Board Layout and Probing (Continued)

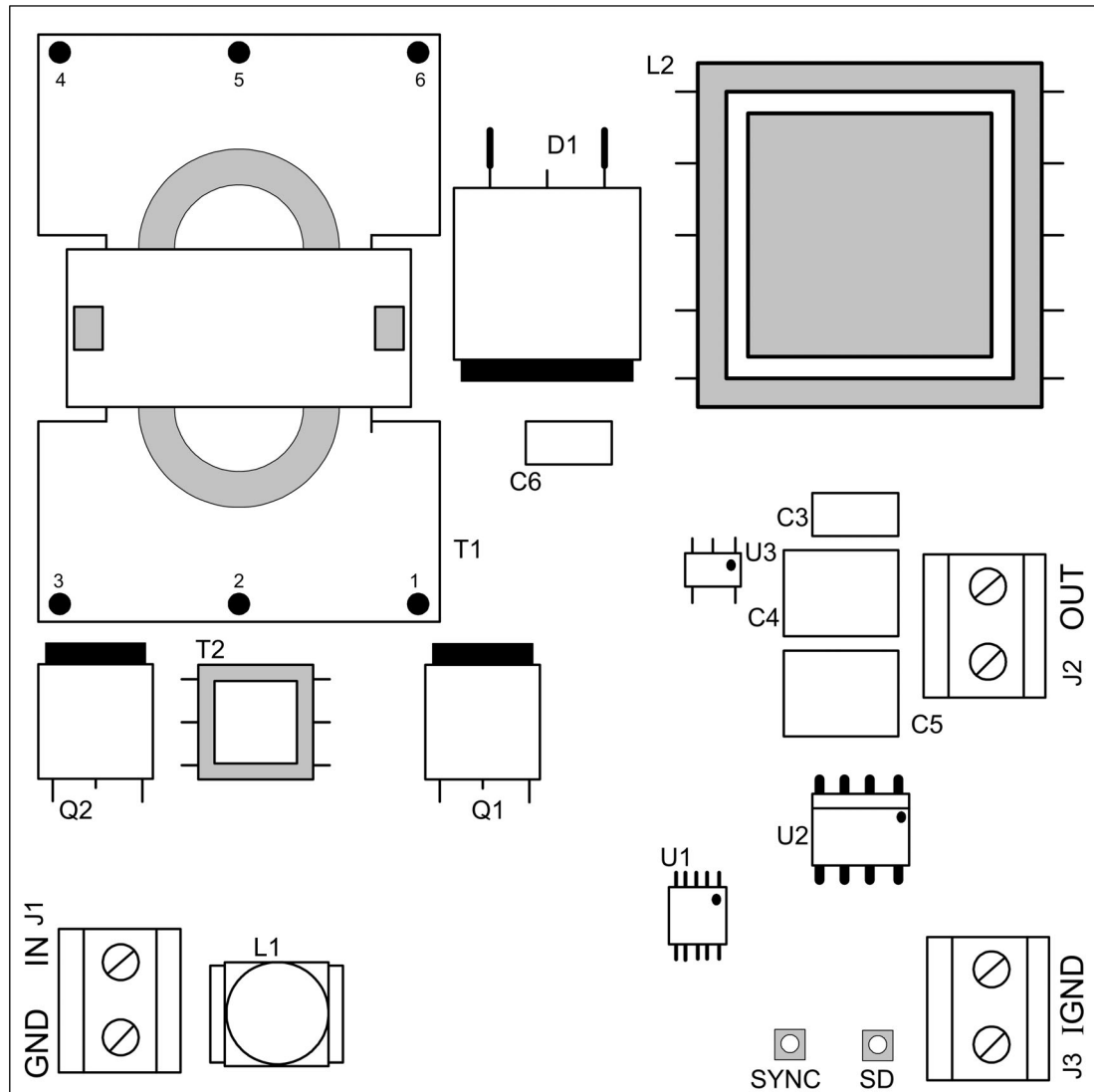

20089201

FIGURE 1. Evaluation Board Pictorial

Board Connections/Start-Up

The input connection to the board from a power supply is made to connector J1. The power supply must be capable of supplying not only the current during normal operation, but also the inrush current during start-up. For example, if the load current is set to be 1.0A, the inrush current will be approximately 250 mA peak. If the load is set to 10A, the inrush current will be approximately 1.7A peak. Once the circuit is on and operating normally, the current draw from the power supply is a function of both the load current, and the input voltage, as shown in *Figure 2*.

The load is connected to the J2 and J3 connectors. Two connectors are provided to accommodate adequately sized wires. With a load current of 10A, the load connections should use a minimum of 16 gauge wire, preferably larger.

Before start-up, a voltmeter should be connected to the input terminals, and one to the output terminals. The input current should be monitored with either an ammeter, or a current probe. Upon turning on the power supply, these three meters should be immediately checked to ensure their readings are nominal.

Performance

Once the circuit is powered up and operating normally, the output voltage will be regulated to +3.3V, with the accuracy determined by the accuracy of the LM3411 regulator driver. As the load current is varied from 1.0 to 10A, the output is regulated to within +/-30 mV (+/- 1.0%). For a given load

Performance (Continued)

current, the output will be regulated to within 5 mV as the input voltage is varied over its range (36 - 75V). The power conversion efficiency is shown in *Figure 3*.

Waveforms

If the circuit is to be probed, *Figure 4* shows some of the significant waveforms for various input/output combinations. REMEMBER that there are two circuit grounds, and the scope probe grounds must be connected appropriately.

In the table of *Figure 4*, t_1 and t_2 are in microseconds, while F_s is in kHz. F_s is the frequency of the internal oscillator, which is twice the switching frequency of each MOSFET. All the voltages are in volts with respect to circuit ground. L2 Output is the regulated output at J2, and typically has less than 10mV of ripple. The spikes at the rising edges of V4, V5, V7, and V9 are due to the leakage inductance in T1. The voltage rating of the MOSFETs (Q1, Q2) is determined by the amplitude of these spikes (V4). Their current rating is determined by the input current shown in *Figure 2*, plus a ripple component of approximately 10% in this design.

V_{CC}

While the LM5030 internally generates a voltage at V_{CC} (7.7V), the internal regulator is used mainly during the start-up sequence. Once the load current begins flowing through L2, which is both an inductor for the output filter and a transformer, a voltage is generated at L2's secondary which powers the V_{CC} pin. Once the externally applied voltage exceeds the internal value (7.7V), the internal regulator shuts off, thereby reducing internal power dissipation in the LM5030. L2 is constructed such that the voltage supplied to V_{CC} ranges from approximately 10.6V to approximately 11.3V, depending on the load current. See *Figure 5*.

Current Sense

Monitoring the input current provides a good indication of the circuit's operation. If an overload condition should exist at the output (a partial overload or a short circuit), the input

current would rise above the nominal value shown in *Figure 2*. Transformer T2, in conjunction with D3, R9, R12 and C10, provides a voltage to pin 8 on the LM5030 (CS) which is representative of the input current flowing through its primary. The average voltage seen at pin 8 is plotted in *Figure 6*. If the voltage at the first current sense comparator exceeds 0.5V, the LM5030 disables its outputs, and the circuit enters a cycle-by-cycle current limit mode. If the second level threshold (0.625V) is exceeded due to a severe overload and transformer saturation, the LM5030 will disable its outputs and initiate a softstart sequence. However, the very short propagation delay of the cycle-by-cycle current limiter (CS1), the design of the CS filter (R9, R12, and C10), and the conservative design of the output inductor (L2), may prevent the second level current threshold from being realized on this evaluation board.

Shutdown

The Shutdown pad (SD) on the board connects to the Soft-Start pin on the LM5030 (pin 10), and permits on/off control of the converter by an external switch. SD should be pulled below 0.45V, with an open collector or open drain device, to shut down the LM5030 outputs and the V_{CC} regulator. If the voltage at the SD pad is between 1.0 and 1.5V, a partial-on condition results, which could be disruptive to the system. Therefore, the voltage at the SD pad should transition quickly between its open circuit voltage (4.9V) and ground.

External Sync

Although the LM5030 includes an internal oscillator, its operating frequency can be synchronized to an external signal if desired. The external source frequency must be higher than the internal frequency set with the RT resistor (262kHz with $R_T = 20K$). The sync input pulse width must be between 15 and 150 ns, and have an amplitude of 1.5 - 3.0V at the Sync pad on the board. The pulses are coupled to the LM5030 through a 100pF capacitor (C16) as specified in the data sheet.

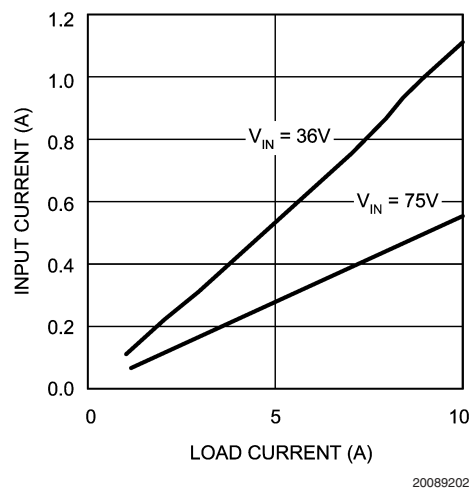

FIGURE 2. Input Current vs Load Current and V_{IN}

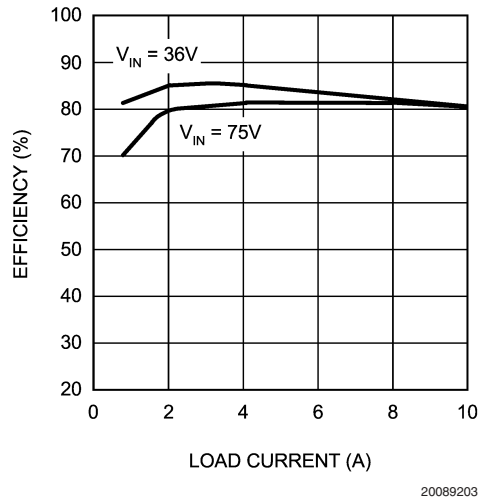
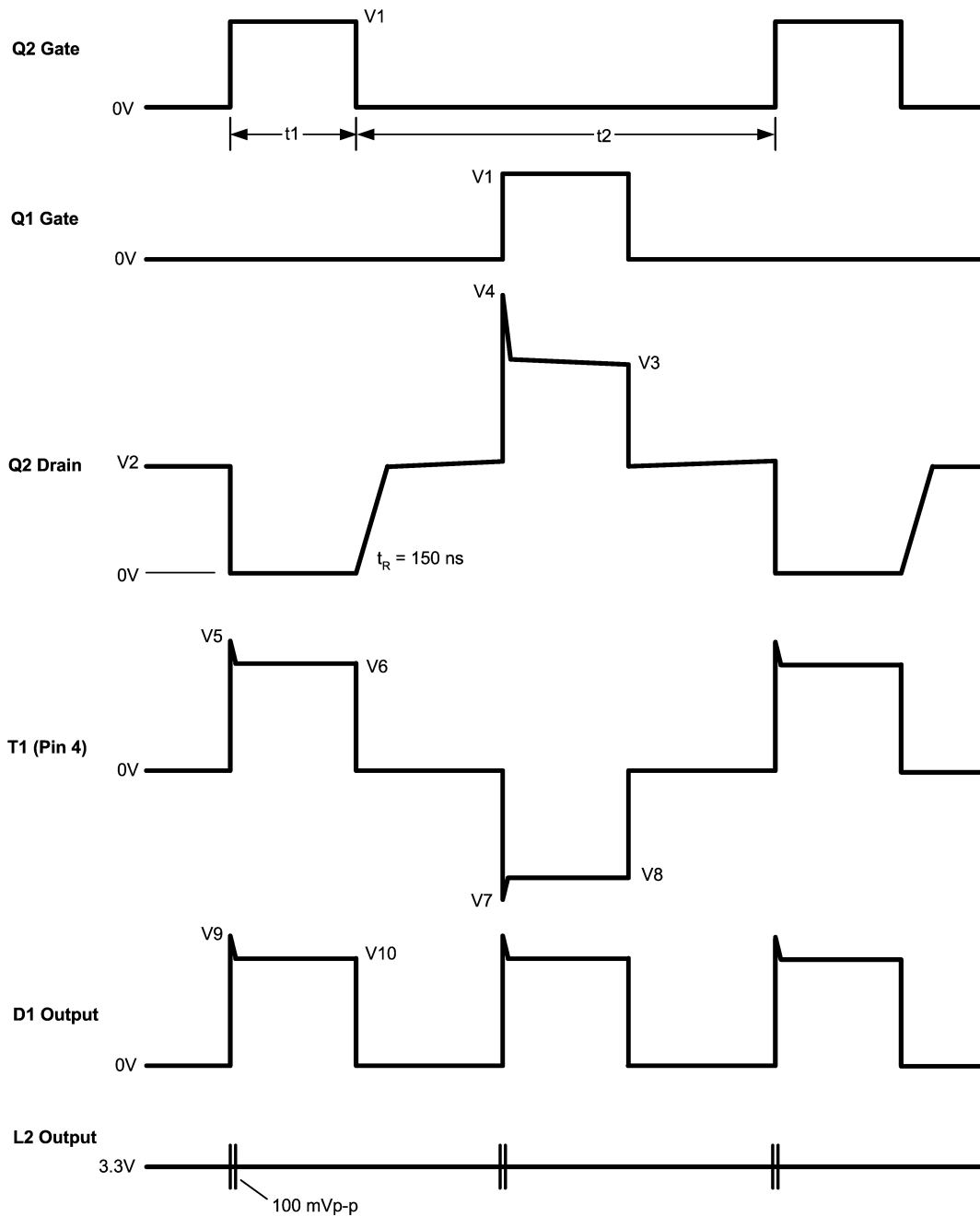

FIGURE 3. Efficiency vs Load Current and V_{IN}



20089204

V_{IN}	I_{OUT}	t_1	t_2	F_s	V1	V2	V3	V4	V5	V6	V7	V8	V9	V10
36V	1.0A	2.2 μ S	5.3 μ S	266.7	10.5V	36V	72V	90V	10V	6V	-10V	-6V	10V	6V
48V	10A	1.9 μ S	5.5 μ S	270.3	11.5V	48V	96V	130V	18V	8V	-18V	-8V	13V	8V
75V	1.0A	1.2 μ S	6.2 μ S	270.3	10.5V	75V	150V	200V	20V	13V	-20V	-13V	20V	13V

FIGURE 4. Representative Waveforms

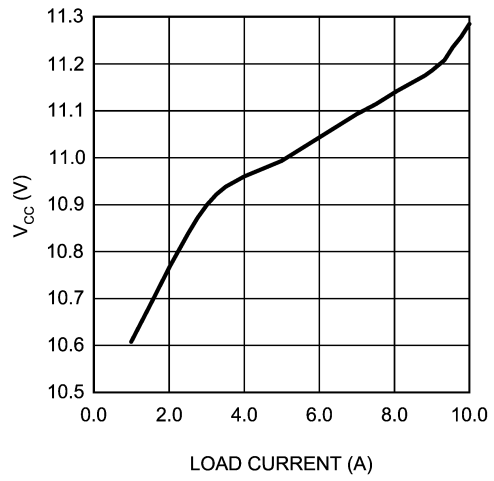

20089205

FIGURE 5. V_{CC} Voltage vs Load Current

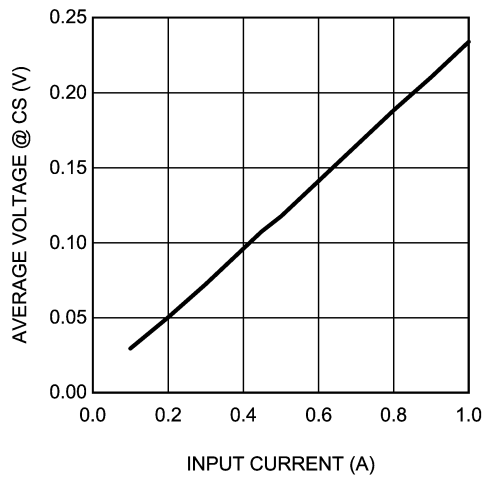

20089206

FIGURE 6. Average Voltage at the CS pin vs Input Current

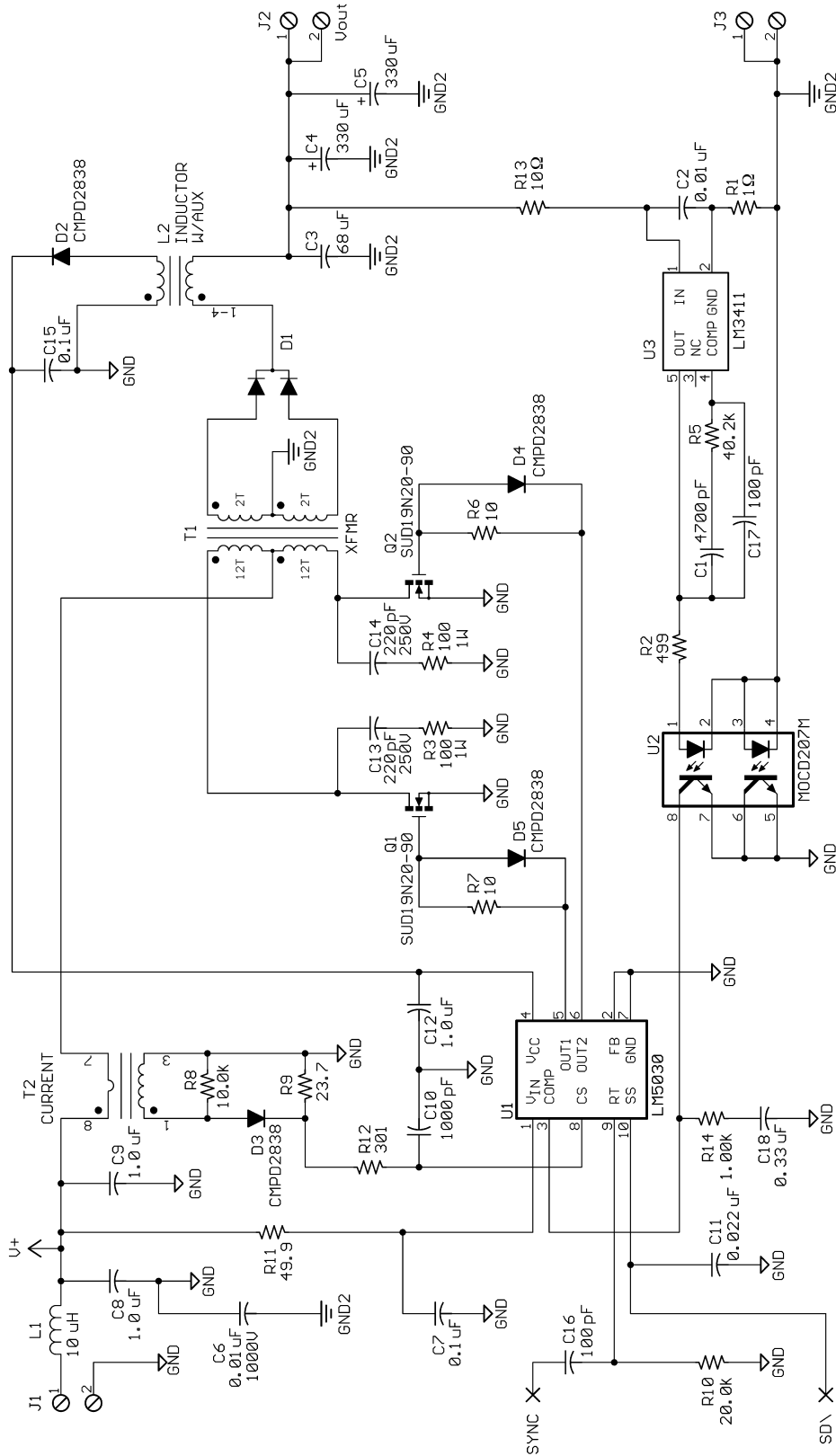

FIGURE 7. Board Schematic

20089207

Bill Of Materials (for the circuit of *Figure 7*)

ITEM	PART NUMBER	DESCRIPTION	VALUE
C1	C0805C472K5RAC	Capacitor, Ceramic, KEMET	4700pF, 50V
C2	C0805C103K5RAC	Capacitor, Ceramic, KEMET	0.01 μ F, 50V
C3	C4532X7S0G686M	Capacitor, Ceramic, TDK	68 μ F, 4V
C4, 5	T520D337M006AS4350	Capacitor, Tantalum, KEMET	330 μ F, 6.3V
C6	C4532X7R3A103K	Capacitor, Ceramic, TDK	0.01 μ F, 1000V
C7	C3216X7R2A104K	Capacitor, Ceramic, TDK	0.1 μ F, 100V
C8, 9	C4532X7R2A105M	Capacitor, Ceramic, TDK	1 μ F, 100V
C10	C0805C102K1RAC	Capacitor, Ceramic, KEMET	1000pF, 100V
C11	C1206C223K5RAC	Capacitor, Ceramic, KEMET	0.022 μ F, 50V
C12	C3216X7R1E105M	Capacitor, Ceramic, TDK	1 μ F, 25V
C13, 14	C3216COG2J221J	Capacitor, Ceramic, TDK	220pF, 630V
C15	C1206C104K5RAC	Capacitor, Ceramic, KEMET	0.1 μ F, 50V
C16, 17	C0805C101J1GAC	Capacitor, Ceramic, KEMET	100pF, 100V
C18	C3216X7R1H334K	Capacitor, Ceramic, TDK	0.33 μ F, 50V
D1	MBRB3030CTL	Diode, Schottky, ON Semi.	30V, 15A
D2 - 5	CMPD2838-NSA	Diode, Signal, Central Semi.	75V, 200mA
L1	MSS6132-103	Input Choke, Coilcraft	10 μ H, 1.3A
L2	A9785-B	Output Choke, Coilcraft	7 μ H, 15A
R1	CRCW12061R00F	Resistor, 1206 SMD	1.0
R2	CRCW12064990F	Resistor, 1206 SMD	499
R3, 4	CRCW2512101J	Resistor, 2512 SMD	100, 1 Ω
R5	CRCW12064022F	Resistor, 1206 SMD	40.2K
R6, 7, 13	CRCW120610R0F	Resistor, 1206 SMD	10
R8	CRCW12061002F	Resistor, 1206 SMD	10K
R9	CRCW120623R7F	Resistor, 1206 SMD	23.7
R10	CRCW12062002F	Resistor, 1206 SMD	20K
R11	CRCW120649R9F	Resistor, 1206 SMD	49.9
R12	CRCW12063010F	Resistor, 1206 SMD	301
R14	CRCW12061001F	Resistor, 1206 SMD	1.0K
T1	A9784-B	Power Transformer, Coilcraft	33 Ω , 10A
T2	P8208T	Current Transformer, Pulse Eng.	100:1, 10A
U1	LM5030MM	PWM Regulator, National	
U2	MOCD207M	Opto-Coupler, Fairchild	
U3	LM3411AM5-3.3	Reference Regulator, National	3.3V
Q1, 2	SUD19N20-90	FET, N Channel, Vishay	200V, 19A
J1-3	651-1727010	Dual Terminals, Mouser	3 per Assy.

Note 1: Data sheets for L1, L2, and T1 are available from Coilcraft at http://www.coilcraft.com/prod_pwr.cfm. Select "Magnetics for National Semiconductor 100V Push-Pull Current Mode PWM Controller, LM5030".

Note 2: Data sheet for T2 is available from Pulse Engineering at <http://www.pulseeng.com/default.cfm>.

PCB Layout Diagrams

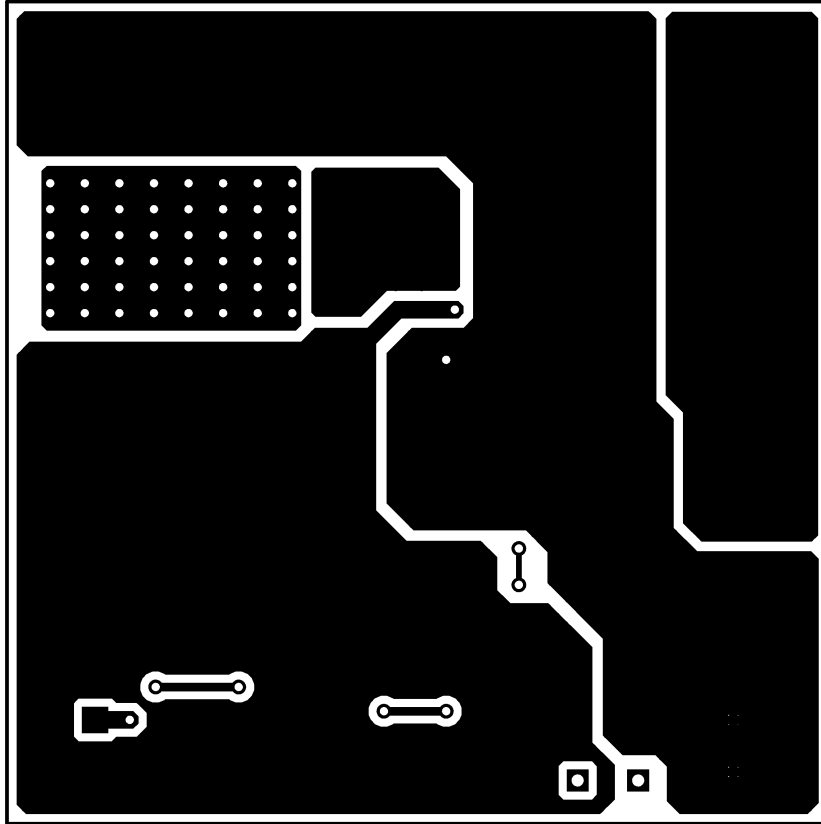

20089208

FIGURE 8. Bottom Layer (viewed from top)

PCB Layout Diagrams (Continued)

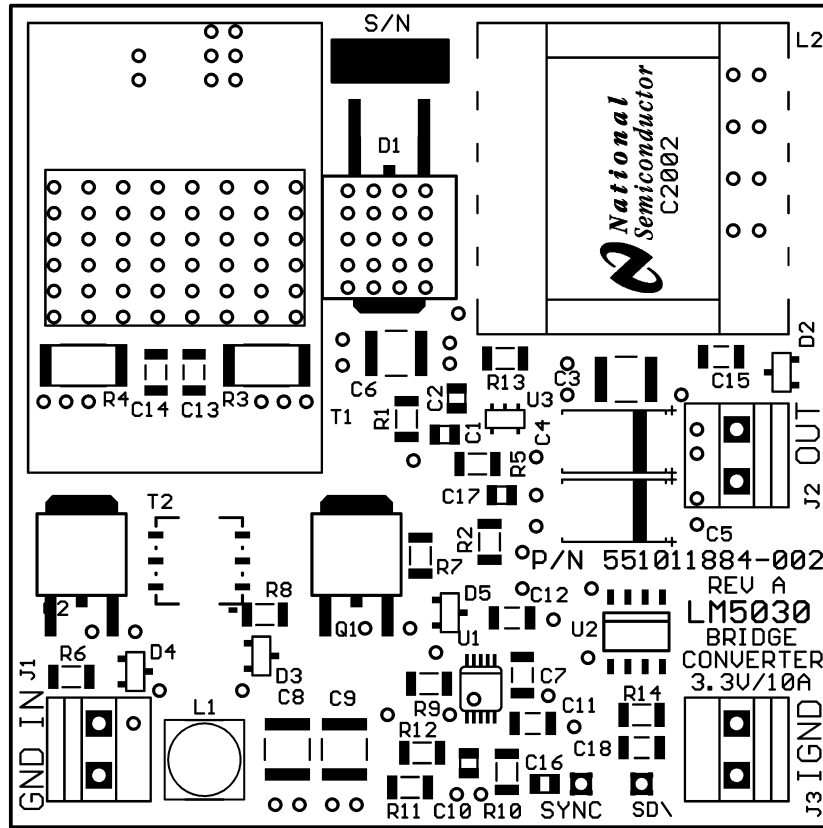

SILKSCREEN LAYER (.PLC) AS VIEWED FROM TOP

20089209

FIGURE 9. Top Silk Screen

PCB Layout Diagrams (Continued)

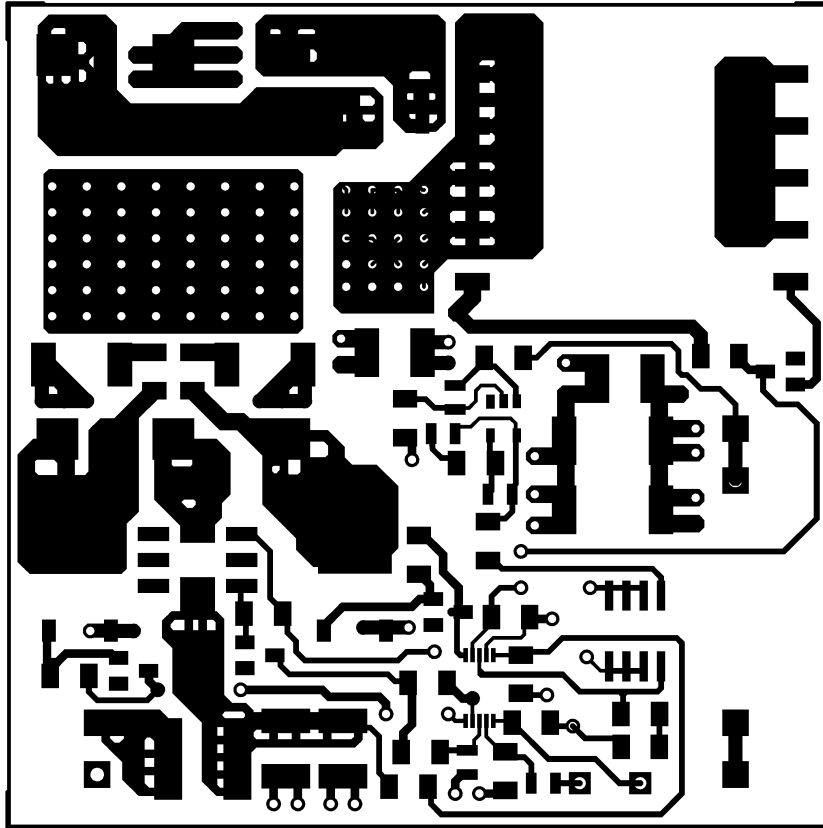

20089210

FIGURE 10. Top Layer

LIFE SUPPORT POLICY

NATIONAL'S PRODUCTS ARE NOT AUTHORIZED FOR USE AS CRITICAL COMPONENTS IN LIFE SUPPORT DEVICES OR SYSTEMS WITHOUT THE EXPRESS WRITTEN APPROVAL OF THE PRESIDENT AND GENERAL COUNSEL OF NATIONAL SEMICONDUCTOR CORPORATION. As used herein:

1. Life support devices or systems are devices or systems which, (a) are intended for surgical implant into the body, or (b) support or sustain life, and whose failure to perform when properly used in accordance with instructions for use provided in the labeling, can be reasonably expected to result in a significant injury to the user.
2. A critical component is any component of a life support device or system whose failure to perform can be reasonably expected to cause the failure of the life support device or system, or to affect its safety or effectiveness.

BANNED SUBSTANCE COMPLIANCE

National Semiconductor certifies that the products and packing materials meet the provisions of the Customer Products Stewardship Specification (CSP-9-111C2) and the Banned Substances and Materials of Interest Specification (CSP-9-111S2) and contain no "Banned Substances" as defined in CSP-9-111S2.



National Semiconductor
Americas Customer
Support Center
Email: new.feedback@nsc.com
Tel: 1-800-272-9959

National Semiconductor
Europe Customer Support Center
Fax: +49 (0) 180-530 85 86
Email: europa.support@nsc.com
Deutsch Tel: +49 (0) 69 9508 6208
English Tel: +44 (0) 870 24 0 2171
Français Tel: +33 (0) 1 41 91 8790

National Semiconductor
Asia Pacific Customer
Support Center
Email: ap.support@nsc.com

National Semiconductor
Japan Customer Support Center
Fax: 81-3-5639-7507
Email: jpn.feedback@nsc.com
Tel: 81-3-5639-7560

www.national.com