

- NOTES
2. CRIMP FOR 22 TO 26 GA. WIRE WITH MAX. INSULATION DIA. OF (1.65)/.065
 3. PLATINGS CONFORM TO MOLEX ENG. STD. SDES-88.
 4. DIMENSIONS GIVEN ACROSS CENTERLINES ARE SYMMETRICAL ABOUT THOSE CENTERLINES WITHIN HALF THE TOTAL TOLERANCE.
 5. PARTS CONFORM TO PRODUCT SPECIFICATION PS-40-02.

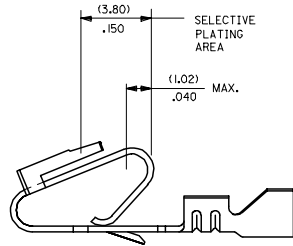

SELECTIVE PLATING AREA

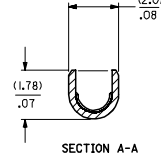
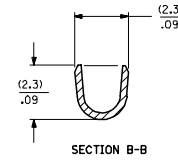
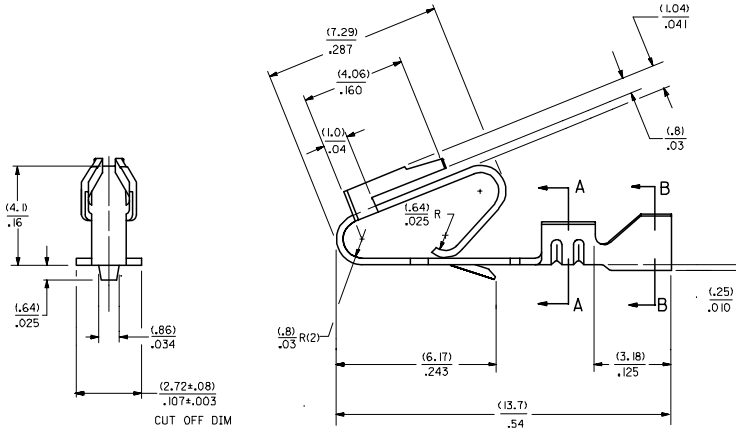
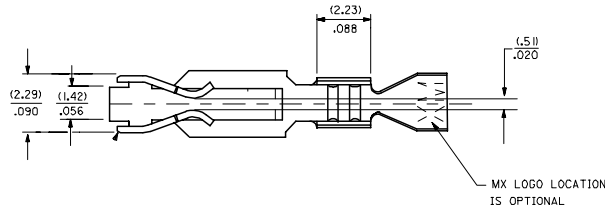
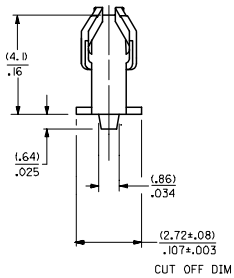

CUT OFF DIM

7258-1(1)
 MAT'L (.27)±.0106 THK J FORM
 BLANK=BRASS BLANK= CHAIN PER DETAIL B
 A=PHOS. BRONZE A=CHAIN PER DETAIL A
 L= LOOSE

PLATING PER SDES- 88

- (909) * OVERALL HOT TIN DIP: .00254 MICROMETERS MIN.
- (558) SELECT GOLD: .00076 MICROMETERS MIN.
- OVERALL GOLD FLASH: .00005 MICROMETERS MIN.
- OVERALL NICKEL UNDERPLATE: .00127 MICROMETERS MIN.
- (561) SELECT GOLD: .00076 MICROMETERS MIN.
- OVERALL NICKEL UNDERPLATE: .00127 MICROMETERS MIN.

*THE PRIMARY SHIPPING CARTON WILL BE LABELED "COMPLIANT TO RoHS DIRECTIVE 2002/95/EC AND ELV ANNEX II OF DIRECTIVE 2000/53/EC." CARTONS WITHOUT THIS LABEL MAY CONTAIN PRODUCT WITH TIN-LEAD PLATING.

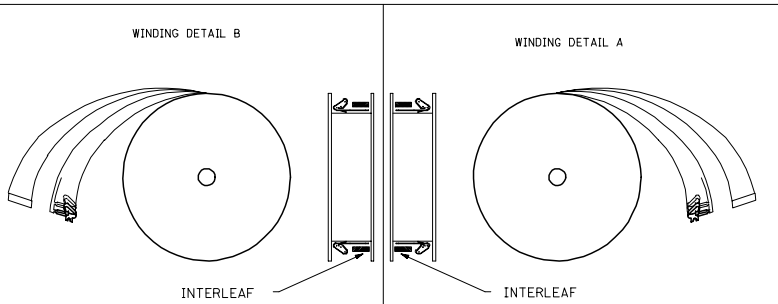

CHANGE TO ME10 IEC NO: UCP2005-0964 DRW: WADPATNOL 2004/11/19 CHK: KSAMEC 2006/04/25 APPR: MMARGULIS 2004/11/02	QUALITY SYMBOLS ▽=0 ▽=0	GENERAL TOLERANCES (UNLESS SPECIFIED) mm INCH 4 PLACES ± .15 ± .006 3 PLACES ± .10 ± .004 2 PLACES ± 0.25 ± .014 1 PLACE ± 0.36 ± .014 ANGULAR ±1/2°	DIMENSION STYLE IN/MM DRAWN BY DATE JJS 12/03/87 CHECKED BY DATE PATEL 12/03/87 APPROVED BY DATE LENZ 12/03/87	SCALE --- DESIGN UNITS INCH THIRD ANGLE PROJECTION	TITLE TRIFURCON TERMINAL CRIMP TYPE, .156 CENTERS 22 TO 26 AWG	
	MATERIAL NO. SD-7258	DOCUMENT NO. SD-7258	SHEET NO. 1 OF 2	MOLEX INCORPORATED		
	DRAFT WHERE APPLICABLE MUST REMAIN WITHIN DIMENSIONS		SIZE D			
	THIS DRAWING CONTAINS INFORMATION THAT IS PROPRIETARY TO MOLEX INCORPORATED AND SHOULD NOT BE USED WITHOUT WRITTEN PERMISSION					

20 19 18 17 16 15 14 13 12 11 10 9 8 7 6 5 4 3 2 1

7258-(*)*

7258-A(*)*

PART NO.	ENG. NO.	PART NO.	ENG. NO.	PART NO.	ENG. NO.	PART NO.	ENG. NO (SUFFIX ONLY)	PART NO.	ENG. NO (SUFFIX ONLY)	VOID CKT.	PART NO.	ENG. NO (SUFFIX ONLY)	VOID CKT.
08-50-0183	7258-(P909)	08-04-0001	7258-A(999)										
08-50-0185	7258-(P909)IL	08-65-0121	7258-A(P56)IL	ES-276-P561									
08-56-0181	7258-(503)	08-65-0122	7258-A(P56)IL										
08-56-0182	7258-(503)IL	08-56-0123	7258-A(P558)	MAKE FROM									
08-50-0283	7258-(P909)IA	08-56-0124	7258-A(P558)IL	7258-A(P56)IL									
			7258-A(56)IL										
			7258-A(56)IL										
		08-52-0124	7258-A(P909)										
		08-52-0125	7258-A(P909)IL										
		08-65-0126	7258-A(P555)										
		08-65-0127	7258-A(P555)IL	ES-276-P555									
		08-58-0133	7258-A(550)IL	MAKE FROM									
		08-58-0134	7258-A(550)IL	7258-A(P555)									

COLUMN NO. 1 CONT. IN COLUMN NO. SHEET NO. COLUMN NO. 2 CONT. IN COLUMN NO. SHEET NO. COLUMN NO. 3 CONT. IN COLUMN NO. SHEET NO. COLUMN NO. 4 CONT. IN COLUMN NO. SHEET NO. COLUMN NO. 4 CONT. IN COLUMN NO. SHEET NO. COLUMN NO. 4 CONT. IN COLUMN NO. SHEET NO.

CHANGE TO ME10 DEC NO. UCP2005-0964 DRAWN BY: JJS CHKCD: SAMEC 2006040959 APPR: MARGULLIS 2006111005 T1 REV DESCRIPTION	QUALITY SYMBOLS	GENERAL TOLERANCES (UNLESS SPECIFIED)	DIMENSION STYLE	SCALE	DESIGN UNITS	THIRD ANGLE PROJECTION															
	$\nabla=0$ $\nabla=0$	<table border="1"> <tr> <th></th> <th>mm</th> <th>INCH</th> </tr> <tr> <td>4 PLACES</td> <td>± ---</td> <td>± ---</td> </tr> <tr> <td>3 PLACES</td> <td>± ---</td> <td>± ---</td> </tr> <tr> <td>2 PLACES</td> <td>± ---</td> <td>± ---</td> </tr> <tr> <td>1 PLACE</td> <td>± ---</td> <td>± ---</td> </tr> </table>		mm	INCH	4 PLACES	± ---	± ---	3 PLACES	± ---	± ---	2 PLACES	± ---	± ---	1 PLACE	± ---	± ---	IN/MM	---	INCH	
		mm	INCH																		
	4 PLACES	± ---	± ---																		
3 PLACES	± ---	± ---																			
2 PLACES	± ---	± ---																			
1 PLACE	± ---	± ---																			
	<table border="1"> <tr> <td>DRAWN BY</td> <td>DATE</td> </tr> <tr> <td>CHECKED BY</td> <td>DATE</td> </tr> <tr> <td>APPROVED BY</td> <td>DATE</td> </tr> </table>	DRAWN BY	DATE	CHECKED BY	DATE	APPROVED BY	DATE	<table border="1"> <tr> <td>TITLE</td> <td>TRIFURCON TERMINAL CRIMP TYPE</td> </tr> <tr> <td>MATERIAL NO.</td> <td>LENZ</td> </tr> <tr> <td>DOCUMENT NO.</td> <td>SD-7258</td> </tr> <tr> <td>SHEET NO.</td> <td>2</td> </tr> </table>	TITLE	TRIFURCON TERMINAL CRIMP TYPE	MATERIAL NO.	LENZ	DOCUMENT NO.	SD-7258	SHEET NO.	2					
DRAWN BY	DATE																				
CHECKED BY	DATE																				
APPROVED BY	DATE																				
TITLE	TRIFURCON TERMINAL CRIMP TYPE																				
MATERIAL NO.	LENZ																				
DOCUMENT NO.	SD-7258																				
SHEET NO.	2																				
	DRAFT WHERE APPLICABLE MUST REMAIN WITHIN DIMENSIONS	SEE CHART SIZE D	THIS DRAWING CONTAINS INFORMATION THAT IS PROPRIETARY TO MOLEX INCORPORATED AND SHOULD NOT BE USED WITHOUT WRITTEN PERMISSION																		

19 18 17 16 15 14 13 12 11 10 9 8 7 6 5 4 3 2 1