

NOTES

- MATERIAL : HEADER -PA66, PBT/PC
PIN : BRASS(CDA 2700)
- FINISHES : PIN
THICKNESS - TIN PLATED 3.0 MICROMETER MIN.
OVER Cu 1.5 MICROMETER MIN.
- PRODUCT SPECIFICATION : PS-35979-001

LEGEND

35979-****

- COLOR : 0 - WHITE
1 - BLACK
2 - RED
3 - YELLOW
4 - BLUE
- PIN LENGTH : 1 - SHORT PIN (PA66) 4 - SHORT PIN (PBT/PC)
3 - LONG PIN (PA66) 6 - LONG PIN (PBT/PC)
- CIRCUIT NO. (02.03.04...)

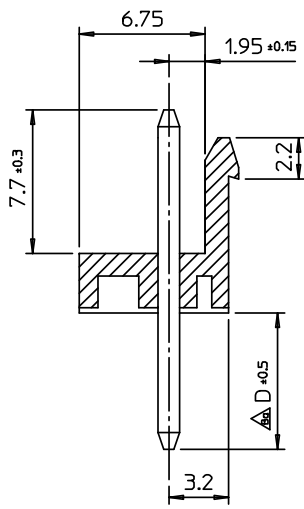

SECTION A-A

9.4	3.7	56.50	55.44	59.40	3597908**	35979-08**	8	15
		48.58	47.52	51.48	3597907**	35979-07**	7	13
		40.66	39.60	43.56	3597906**	35979-06**	6	11
9.7	3.7	32.74	31.68	35.64	3597905**	35979-05**	5	9
		24.82	23.76	27.72	3597904**	35979-04**	4	7
		16.90	15.84	19.80	3597903**	35979-03**	3	5
		8.98	7.92	11.88	3597902**	35979-02**	2	3
E	Δ 11.4	8.98	7.92	11.88	3597902**	35979-02**	2	
		D	C	B	A	MAT'L NO	ENG NO.	CKT N

REVISED EC NO: KOR2008-0143 DRWN: JHPARK01 2008/02/26 CHKD: WY YANG 2008/02/26 APPR: YUNSIKKIM 2008/02/27	QUALITY SYMBOLS ▽=0 ▽=0	GENERAL TOLERANCES (UNLESS SPECIFIED)		DIMENSION STYLE MM ONLY		SCALE 3.5:1	DESIGN UNITS METRIC		THIRD ANGLE PROJECTION		
			mm	INCH	DRAWN BY	DATE	7.92 PITCH W-T-B CONN. HEADER ASS'Y				
		4 PLACES	± ---	± ---	YURIWI	1999/05/07					
		3 PLACES	± ---	± ---	CHECKED BY	DATE	MOLEX INCORPORATED				
2 PLACES	± ---	± ---	J.K.OH	1999/05/07							
1 PLACE	± 0.2	± ---	APPROVED BY	DATE	SD-35979-001						
ANGULAR ± 2 °			C.W LEE	1999/05/07							
DRAFT WHERE APPLICABLE MUST REMAIN WITHIN DIMENSIONS		SEE TABLE		MATERIAL NO.		DOCUMENT NO.		SHEET NO.			
				SIZE A3		THIS DRAWING CONTAINS INFORMATION THAT IS PROPRIETARY TO MOLEX INCORPORATED AND SHOULD NOT BE USED WITHOUT WRITTEN PERMISSION		1 OF 01			