

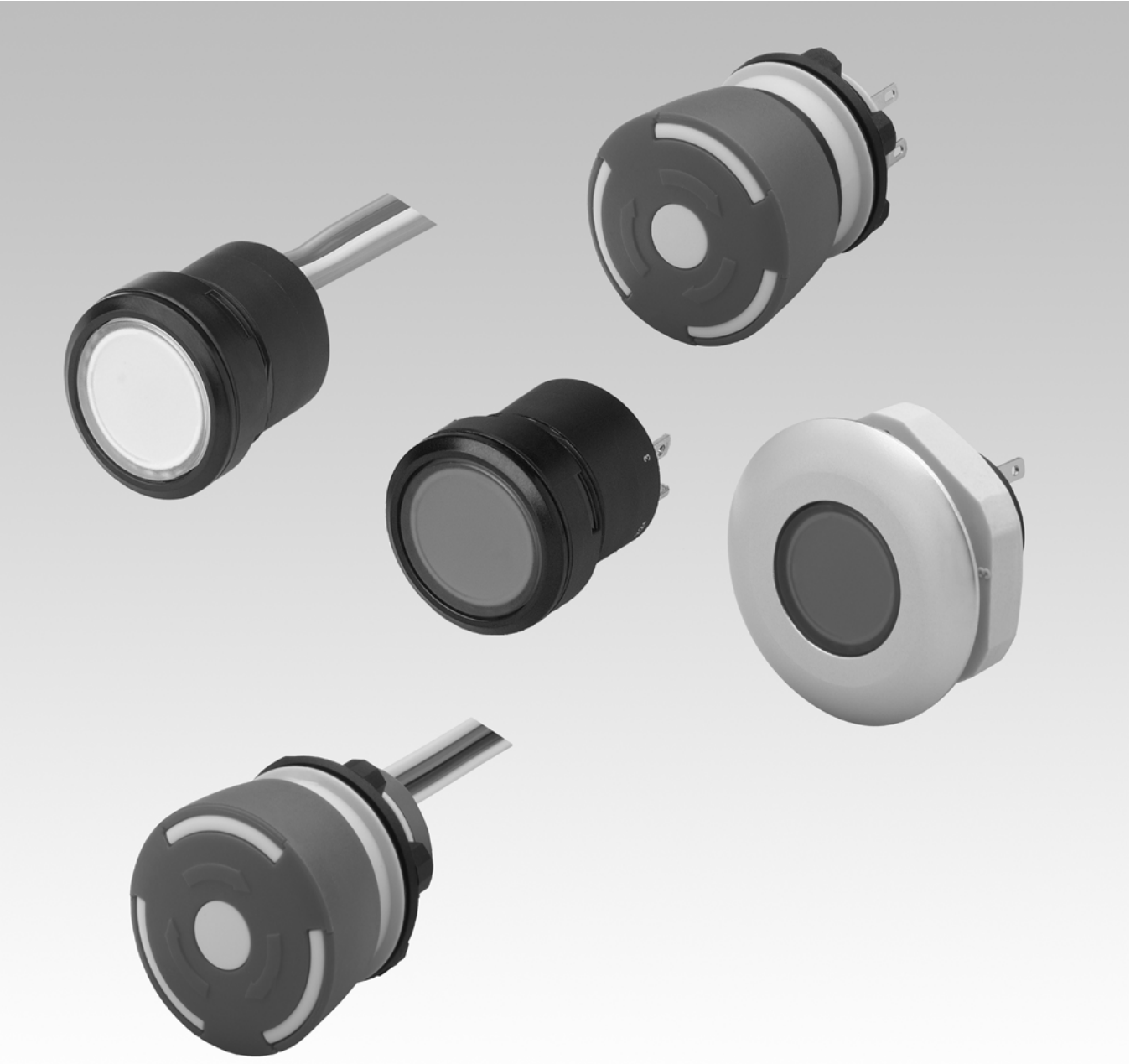

EAO Product Information

Series 84



Description	5
Product Assembly	6
Mounting instruction	8
Devices raised mounting	9
Devices flush mounting	11
Accessories.....	12
Technical Data.....	24
Drawings.....	27
Index.....	38

Product Information

General notes

The Series 84 consists of indicators, pushbuttons and emergency-stop switches. The indicators and pushbuttons are a modular system of lens, actuator, switching element and a variety of means of connection and mounting. Different front protection of IP 67, IP 65 or IP 40 ensure that the pushbuttons are suited for industrial use.

Anodized aluminium parts can have visible variations due production-technical reasons.

Mounting

The actuators of the Series 84 are inserted in a 22.5 mm diameter mounting hole and the switching units are clipped on to the rear of the actuators. The pushbutton system can be mounted as a complete unit (actuator and switching unit). Mounting from the front with the wiring already attached is also possible.

When mounted on printed circuit boards the actuators are inserted in the mounting hole 22.5 mm dia. and the switching elements are fixed on the board. The printed circuit board is connected to the preassembled actuator by means of the mounting flange. There is no need for subsequent adjustment or spacing studs.

Lenses

The flat lenses are available in various colours and made either from plastic or anodized aluminium.

Marking

The lenses of the Series 84 can be marked by engraving, the marking plates are hot stamped.

Specific symbols and markings are available on request.

Illumination

To ensure full illumination, the switching elements can be supplied with integrated Single- or Multi-LEDs in the colours red, orange, yellow, green, blue or white. The series resistor is integrated.

Luminosity and wave length scattering caused by the technology used in the LED manufacturing processes may lead to visual differences in our products.

Emergency-stop pushbutton, foolproof

The E-stop pushbutton can be mounted in front panels with a thickness between 1 and 4 mm. It has a low behind-panel depth of 13.5 mm (max.) and 18.5 mm with plug-in terminlas and can be safely and easily adapted to PCBs of different heights. The front protection degree is IP 65.

Importantly, the Series 84 emergency-stop requires no additional assembly because of its single-piece 'monoblock' design.

The switch's status is clearly indicated by a black or green colour ring on the shaft, and the foolproof actuator design conforms to DIN EN ISO 13850 and EN IEC 60947.

It can be supplied with LED illumination that is visible even from the side.

Specimen order

Indicator :

- Indicator actuator, IP 67 84-0100.0

Essential accessories :

- Lens plastic blue 84-7111.600
- Indicator element, IP 67 84-8001.6620
- Single-LED blue 24 V, plug-in terminal

or

Indicator with PCB terminal :

- Indicator actuator, IP 67 84-3100.1

Essential accessories :

- Lens plastic red 84-7111.200
- Indicator element with PCB terminal 92-800.042
- Single-LED red 2.2 V 10-2602.3172D
- Mounting flange 92-960.0

*We reserve the right to modify technical data
All dimensions in mm*

Indicator and pushbutton illuminative, 25 mm dia.

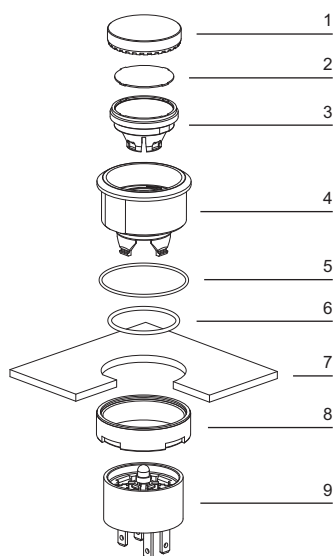

- 1 Lens
- 2 Marking plate
- 3 Lens holder
- 4 Actuator housing
- 5 Outer sealing
- 6 Inner sealing
- 7 Front panel
- 8 Fixing nut
- 9 Switching-/Illumination element with plug-in terminal (solderable)

Indicator and pushbutton illuminative, 40 mm dia.

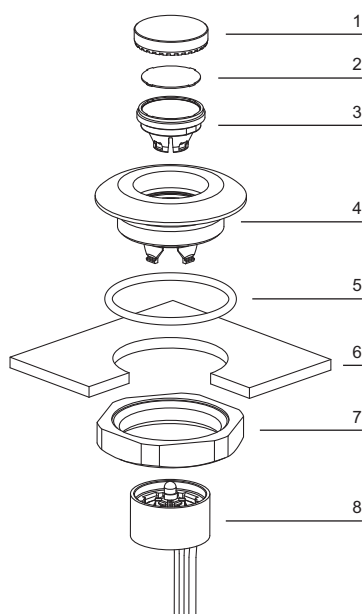

- 1 Lens
- 2 Marking plate
- 3 Lens holder
- 4 Actuator housing
- 5 Sealing
- 6 Front panel
- 7 Fixing nut
- 8 Switching-/Illumination element with flat ribbon cable

Indicator and pushbutton illuminative, 25 mm dia., PCB version

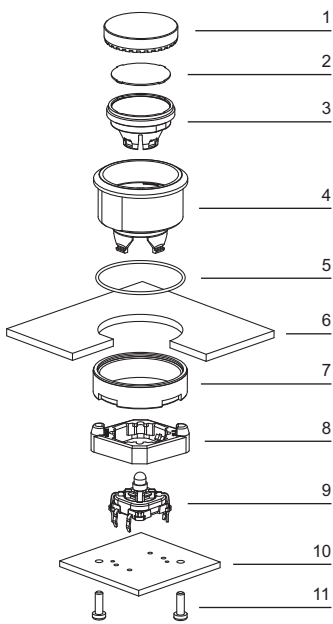

- 1 Lens
- 2 Marking plate
- 3 Lens holder
- 4 Actuator housing
- 5 Sealing
- 6 Front panel
- 7 Fixing nut
- 8 Mounting flange
- 9 Switching-/Illumination element with PCB terminal
- 10 PCB
- 11 Fixing screws

Emergency-stop pushbutton

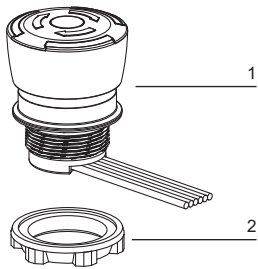

- 1 Emergency-stop pushbutton
- 2 Fixing nut

Arrangement mounting flange for Switching- and Illumination element, PCB version

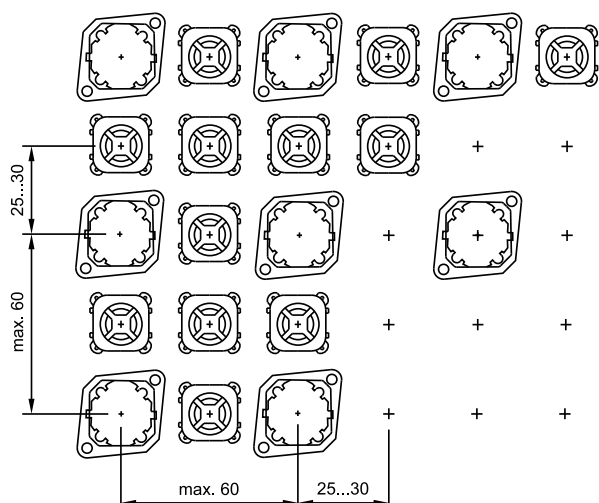

The arrangement of the mounting flanges and their number is determined by the size of the front panel or PCB. To ensure uniform, tactile switching, we recommend a layout of the flanges as per adjacent sketch.

For large PCBs with several switching elements we recommend the following procedure :

1. Fit the actuator to the front panel.
2. Clip the mounting flange to the rear of the intended actuator.
3. Screw the PCB with the components soldered to it to the assembled mounting flange.

This arrangement applies to PCBs 1.6 mm thick.

Dismantling mounting flange

The tool 84-998 must be used for removing the mounting flange from the actuator. Before removing the flange, the PCB fixing screws must be loosened.

Emergency-stop pushbutton, foolproof EN IEC 60947-5-5, complete

Application as per DIN EN ISO 13850 and EN 60204-1



	Front protection	Switching action	Mushroom had cap	Illumination	Terminals	Contacts	Ø 32 mm Typ-Nr.	Component layout	Mounting dimensions	Technical drawing	Circuit drawing	
Emergency-stop pushbutton, foolproof EN IEC 60947-5-5, complete Position indication ring black Twist to unlock clockwise	IP 65	MA	Plastic red	without	FR	1 NC	84-5020.0040	2	2	15	5	0.036
						1 NC + 1 NO	84-5030.0040	2	2	15	6	0.036
						2 NC	84-5040.0040	2	2	15	7	0.036
					PT 2.8 s	1 NC	84-5020.0020	1	2	15	5	0.028
						1 NC + 1 NO	84-5030.0020	1	2	15	6	0.028
						2 NC	84-5040.0020	1	2	15	7	0.028
Position indication ring black Twist to unlock clockwise LED operating voltage : 5 ... 30 VDC Current consumption : 9.7 ... 12.4 mA	IP 65	MA	Plastic red	LED red	FR	1 NC	84-5021.2B40	2	2	15	8	0.036
						1 NC + 1 NO	84-5031.2B40	2	2	15	9	0.036
						2 NC	84-5041.2B40	2	2	15	10	0.036
					PT 2.8 s	1 NC	84-5021.2B20	1	2	15	8	0.028
						1 NC + 1 NO	84-5031.2B20	1	2	15	9	0.028
						2 NC	84-5041.2B20	1	2	15	10	0.028
Position indication ring green Twist to unlock clockwise	IP 65	MA	Plastic red	without	FR	1 NC	84-5120.0040	2	2	15	5	0.036
						1 NC + 1 NO	84-5130.0040	2	2	15	6	0.036
						2 NC	84-5140.0040	2	2	15	7	0.036
					PT 2.8 s	1 NC	84-5120.0020	1	2	15	5	0.028
						1 NC + 1 NO	84-5130.0020	1	2	15	6	0.028
						2 NC	84-5140.0020	1	2	15	7	0.028
Position indication ring green Twist to unlock clockwise LED operating voltage : 5 ... 30 VDC Current consumption : 9.7 ... 12.4 mA	IP 65	MA	Plastic red	LED red	FR	1 NC	84-5121.2B40	2	2	15	8	0.036
						1 NC + 1 NO	84-5131.2B40	2	2	15	9	0.036
						2 NC	84-5141.2B40	2	2	15	10	0.036
					PT 2.8 s	1 NC	84-5121.2B20	1	2	15	7	0.028
						1 NC + 1 NO	84-5131.2B20	1	2	15	9	0.028
						2 NC	84-5141.2B20	1	2	15	10	0.028

Standard version :

Flat ribbon-cable length 300 mm; Plug-in terminal 2.8 x 0.5 mm

Other options on request :

Customisation of flat ribbon-cable and connectors

Switching action: MA = Maintained action

Terminals: FR = Flat ribbon cable, PT 2.8 s = Plug-in terminal 2.8 mm (solderable)

Contacts: NC = Normally closed, NO = Normally open

Component layout from page 27, Mounting dimensions from page 28, Technical drawing from page 29, Circuit drawing from page 36

Stop-Switch grey, complete



	Front protection	Switching action	Mushroom had cap	Illumination	Terminals	Contacts	Ø 32 mm Typ-Nr.	Component layout		Mounting dimensions	Technical drawing	Circuit drawing	EPA
Stop-Switch grey, complete Position indication ring black Twist to unlock clockwise	IP 65	MA	Plastic grey	without	FR	1 NC	84-6020.0040	2	2	15	5	0.036	
						1 NC + 1 NO	84-6030.0040	2	2	15	6	0.036	
						2 NC	84-6040.0040	2	2	15	7	0.036	
					PT 2.8 s	1 NC	84-6020.0020	1	2	15	5	0.028	
						1 NC + 1 NO	84-6030.0020	1	2	15	6	0.028	
						2 NC	84-6040.0020	1	2	15	7	0.028	
Position indication ring black Twist to unlock clockwise LED operating voltage : 5 ... 30 VDC Current consumption : 9.7 ... 12.4 mA	IP 65	MA	Plastic grey	LED red	FR	1 NC	84-6021.2B40	2	2	15	8	0.036	
						1 NC + 1 NO	84-6031.2B40	2	2	15	9	0.036	
						2 NC	84-6041.2B40	2	2	15	10	0.036	
					PT 2.8 s	1 NC	84-6021.2B20	1	2	15	8	0.028	
						1 NC + 1 NO	84-6031.2B20	1	2	15	9	0.028	
						2 NC	84-6041.2B20	1	2	15	10	0.028	

Standard version :

Flat ribbon-cable length 300 mm; Plug-in terminal 2.8 x 0.5 mm

Other options on request :

Customisation of flat ribbon-cable and connectors

Switching action: MA = Maintained action

Terminals: FR = Flat ribbon cable, PT 2.8 s = Plug-in terminal 2.8 mm (solderable)



Contacts: NC = Normally closed, NO = Normally open

Component layout from page 27, Mounting dimensions from page 28, Technical drawing from page 29, Circuit drawing from page 36

Indicator actuator, flush mounting



Essential Accessories:

-  Illumination element page 15
-  Lens metal, Halo illumination page 13
-  Lens plastic page 12

	Front protection	Front ring	Ø 25 mm Typ-Nr.	Mounting dimensions	Technical drawing	
Indicator actuator, flush mounting	IP 40	Plastic black	84-3100.0	1 14	0.004	
	IP 67	Aluminium natural	84-0200.7	1 14	0.008	
		Plastic black	84-0100.0	1 14	0.003	
Halo illumination	IP 67	Plastic translucent	84-0090.7	1 14	0.006	

Accessories for Halo illumination:

Essential lenses Typ-Nr. 84-7205.x00A



Recommended illumination elements Typ-Nr. 84-8001.xxx0 (only Single-LED blue, green and white)

Mounting dimensions from page 28, Technical drawing from page 29

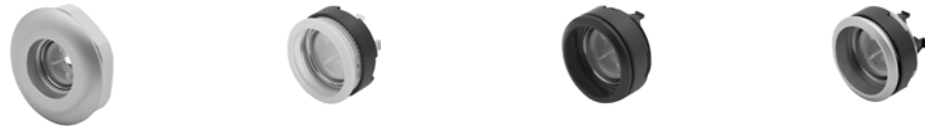
Illuminated pushbutton actuator, flush mounting



Essential Accessories:

-  Lens metal, Halo illumination page 13
-  Lens plastic page 12
-  Switching element illuminated page 16

	Switching action	Front protection	Front ring	Ø 40 mm Typ-Nr.	Ø 25 mm Typ-Nr.	Mounting dimensions	Technical drawing	Circuit drawing	
Illuminated pushbutton actuator, flush mounting illuminative	M	IP 67	Aluminium natural	84-1221.7		3 21	1	0.022	
Halo illumination illuminative	M	IP 67	Plastic translucent		84-1091.7	1 14	1	0.006	
	M	IP 40	Plastic black		84-2101.0	1 14	1	0.004	
			Aluminium natural		84-1201.7	1 14	1	0.008	
		Plastic black		84-1101.0	1 14	1	0.003		

Accessories for Halo illumination:

Essential lenses Typ-Nr. 84-7205.x00A

Recommended switching elements Typ-Nr. 84-8511.xxx0 (only Single-LED blue, green and white)

Switching action: M = Momentary action

Mounting dimensions from page 28, Technical drawing from page 29, Circuit drawing from page 36

Front

Lens plastic

	Lens	Ø 25 mm Typ-Nr.	
Lens plastic flush, illuminative	blue transparent	84-7111.600	0.001
	colourless transparent	84-7111.700	0.001
	green transparent	84-7111.500	0.001
	orange transparent	84-7111.300	0.001
	red transparent	84-7111.200	0.001
	yellow transparent	84-7111.400	0.001
flush, non-illuminative	black opaque	84-7121.000	0.001
	grey opaque	84-7121.800	0.001
raised, illuminative	blue transparent	84-7115.600	0.001
	colourless transparent	84-7115.700	0.001
	green transparent	84-7115.500	0.001
	orange transparent	84-7115.300	0.001
	red transparent	84-7115.200	0.001
	yellow transparent	84-7115.400	0.001
raised, non-illuminative	black opaque	84-7125.000	0.001
	grey opaque	84-7125.800	0.001



Marking plate for Lens plastic

can be hot stamped

	Marking plate	Typ-Nr.	
Marking plate for Lens plastic	Plastic colourless transparent	61-9707.7	0.001



Lens metal

	Lens	Ø 25 mm Typ-Nr.	
Lens metal convex	Aluminium black	84-7202.000	0.003
	Aluminium blue	84-7202.600	0.003
	Aluminium green	84-7202.500	0.003
	Aluminium natural	84-7202.800	0.003
	Aluminium red	84-7202.200	0.003
	Aluminium yellow	84-7202.400	0.003
flush	Aluminium black	84-7201.000	0.003
	Aluminium blue	84-7201.600	0.003
	Aluminium green	84-7201.500	0.003
	Aluminium natural	84-7201.800	0.003
	Aluminium red	84-7201.200	0.003
	Aluminium yellow	84-7201.400	0.003
raised	Aluminium black	84-7205.000	0.003
	Aluminium blue	84-7205.600	0.003
	Aluminium green	84-7205.500	0.003
	Aluminium natural	84-7205.800	0.003
	Aluminium red	84-7205.200	0.003
	Aluminium yellow	84-7205.400	0.003



Lens metal, Halo illumination

	Lens	Typ-Nr.	
Lens metal, Halo illumination raised	Aluminium black	84-7205.000A	0.003
	Aluminium blue	84-7205.600A	0.003
	Aluminium green	84-7205.500A	0.003
	Aluminium natural	84-7205.800A	0.003
	Aluminium red	84-7205.200A	0.003
	Aluminium yellow	84-7205.400A	0.003



Lens metal with window

	Lens	Ø 25 mm Typ-Nr.	
Lens metal with window flush	Aluminium black	84-7211.000	0.002
	Aluminium blue	84-7211.600	0.002
	Aluminium green	84-7211.500	0.002
	Aluminium natural	84-7211.800	0.002
	Aluminium red	84-7211.200	0.002
	Aluminium yellow	84-7211.400	0.002
raised	Aluminium black	84-7215.000	0.002
	Aluminium blue	84-7215.600	0.002
	Aluminium green	84-7215.500	0.002
	Aluminium natural	84-7215.800	0.002
	Aluminium red	84-7215.200	0.002
	Aluminium yellow	84-7215.400	0.002



Mushroom-head cap

	Mushroom had cap	Ø 32 mm Typ-Nr.	
Mushroom-head cap	Plastic black opaque	84-7124.000A	0.004
	Plastic blue opaque	84-7124.600A	0.004
	Plastic green opaque	84-7124.500A	0.004
	Plastic red opaque	84-7124.200A	0.004
	Plastic yellow opaque	84-7124.400A	0.004



Front protective cap

	Front protective cap	Typ-Nr.	
Front protective cap	Silicone natural transparent	84-9103.7	0.001



Legend frame

for devices 25 mm dia.

	Typ-Nr.	Technical drawing	
Legend frame 30 x 50 mm, adhesive, Aluminium black	61-9980.0	8	0.001



Technical drawing from page 29

Legend plate insert

for Legend frame 61-9980.0

	Typ-Nr.	
Legend plate insert 14.5 x 23.5 mm, adhesive, Aluminium black	704.968.1	0.001
14.5 x 23.5 mm, adhesive, Aluminium natural	704.968.0	0.001



Blind plug

	Blind plug	Typ-Nr.	Technical drawing	
Blind plug Size 28 mm dia., for mounting hole 22.5 mm dia.	Plastic black	704.960.4	2	0.004
Size 36 mm dia., for mounting hole 30.5 mm dia.	Plastic black	704.964.8	1	0.007



Technical drawing from page 29

Backside

Illumination element

	Illumination	Operating voltage/-current	Terminals	Typ-Nr.	Circuit drawing	
Illumination element LED and built-in resistor included	Multi-LED green	12 VDC, 40 mA	FR	84-8002.5340	2	0.010
			PT 2.8 s	84-8002.5320	2	0.005
		24 VDC, 20 mA	FR	84-8002.5640	2	0.010
			PT 2.8 s	84-8002.5620	2	0.005
	Multi-LED orange	12 VDC, 40 mA	FR	84-8002.3340	2	0.010
			PT 2.8 s	84-8002.3320	2	0.005
		24 VDC, 20 mA	FR	84-8002.3640	2	0.010
			PT 2.8 s	84-8002.3620	2	0.005
	Multi-LED red	12 VDC, 40 mA	FR	84-8002.2340	2	0.010
			PT 2.8 s	84-8002.2320	2	0.005
		24 VDC, 20 mA	FR	84-8002.2640	2	0.010
			PT 2.8 s	84-8002.2620	2	0.005
	Multi-LED yellow	12 VDC, 40 mA	FR	84-8002.4340	2	0.010
			PT 2.8 s	84-8002.4320	2	0.005
		24 VDC, 20 mA	FR	84-8002.4640	2	0.010
			PT 2.8 s	84-8002.4620	2	0.005
	Single-LED blue	24 VDC, 20 mA	FR	84-8001.6640	2	0.010
			PT 2.8 s	84-8001.6620	2	0.005
	Single-LED green	24 VDC, 20 mA	FR	84-8001.5640	2	0.010
			PT 2.8 s	84-8001.5620	2	0.005
	Single-LED orange	24 VDC, 20 mA	FR	84-8001.3640	2	0.010
			PT 2.8 s	84-8001.3620	2	0.005
	Single-LED red	24 VDC, 20 mA	FR	84-8001.2640	2	0.010
			PT 2.8 s	84-8001.2620	2	0.005
Single-LED white	12 VDC, 40 mA	FR	84-8001.9340	2	0.010	
		PT 2.8 s	84-8001.9320	2	0.005	
	24 VDC, 20 mA	FR	84-8001.9640	2	0.010	
		PT 2.8 s	84-8001.9620	2	0.005	
Single-LED yellow	24 VDC, 20 mA	FR	84-8001.4640	2	0.010	
		PT 2.8 s	84-8001.4620	2	0.005	



Standard version :

Cable length 300 mm; Plug-in terminal 2.8 x 0.8 mm

Other options on request :

Customisation of cable and connectors

For IP 67 back protection, cable version only, use blind plug Typ-Nr. 84-900

Terminals: FR = Flat ribbon cable, PT 2.8 s = Plug-in terminal 2.8 mm (solderable)

Circuit drawing from page 36

Switching element illuminated

	Contacts	Illumination	Operating voltage/-current	Terminals	Typ-Nr.	Circuit drawing	kg
Switching element illuminated LED and built-in resistor included	1 NO	Multi-LED blue	24 VDC, 20 mA	FR	84-8512.6640	4	0.015
				PT 2.8 s	84-8512.6620	4	0.006
		Multi-LED green	12 VDC, 40 mA	FR	84-8512.5340	4	0.015
				PT 2.8 s	84-8512.5320	4	0.006
			24 VDC, 20 mA	FR	84-8512.5640	4	0.015
				PT 2.8 s	84-8512.5620	4	0.006
		Multi-LED orange	12 VDC, 40 mA	FR	84-8512.3340	4	0.015
				PT 2.8 s	84-8512.3320	4	0.006
			24 VDC, 20 mA	FR	84-8512.3640	4	0.015
		PT 2.8 s		84-8512.3620	4	0.006	
		Multi-LED red	12 VDC, 40 mA	FR	84-8512.2340	4	0.015
				PT 2.8 s	84-8512.2320	4	0.006
			24 VDC, 20 mA	FR	84-8512.2640	4	0.015
		PT 2.8 s		84-8512.2620	4	0.006	
		Multi-LED yellow	12 VDC, 40 mA	FR	84-8512.4340	4	0.015
				PT 2.8 s	84-8512.4320	4	0.006
			24 VDC, 20 mA	FR	84-8512.4640	4	0.015
		PT 2.8 s		84-8512.4620	4	0.006	
		Single-LED blue	24 VDC, 20 mA	FR	84-8511.6640	4	0.015
				PT 2.8 s	84-8511.6620	4	0.006
		Single-LED green	24 VDC, 20 mA	FR	84-8511.5640	4	0.015
				PT 2.8 s	84-8511.5620	4	0.006
		Single-LED orange	24 VDC, 20 mA	FR	84-8511.3640	4	0.015
				PT 2.8 s	84-8511.3620	4	0.006
		Single-LED red	24 VDC, 20 mA	FR	84-8511.2640	4	0.015
				PT 2.8 s	84-8511.2620	4	0.006
		Single-LED white	12 VDC, 40 mA	FR	84-8511.9340	4	0.015
				PT 2.8 s	84-8511.9320	4	0.006
24 VDC, 20 mA	FR	84-8511.9640	4	0.015			
	PT 2.8 s	84-8511.9620	4	0.006			
Single-LED yellow	24 VDC, 20 mA	FR	84-8511.4640	4	0.015		
		PT 2.8 s	84-8511.4620	4	0.006		



Standard version :

Cable length 300 mm; Plug-in terminal 2.8 x 0.8 mm

Other options on request :

Customisation of cable and connectors

For IP 67 back protection, cable version only, use blind plug Typ-Nr. 84-900

Contacts: NO = Normally open

Terminals: FR = Flat ribbon cable, PT 2.8 s = Plug-in terminal 2.8 mm (solderable)

Circuit drawing from page 36

Switching element Bi-Color illumination

	Contacts	Illumination	Operating voltage/-current	Terminals	Typ-Nr.	Circuit drawing	
Switching element Bi-Color illumination LED and built-in resistor included	1 NO	Bi-Color LED green/red	24 VDC, 20 mA	FR	84-8515.8640	4	0.014



Protection degree IP 67 back side

Non-removable from actuator anymore

Best illumination level will be reached with Alu lens with window, Typ-Nr. 84-7215.x00 and 84-7211.x00

Layout 5-pol cable 300 mm without connector:

white 0 V

green +24 VDC green

brown +24 VDC LED red

yellow contact

grey contact

Contacts: NO = Normally open

Terminals: FR = Flat ribbon cable

Circuit drawing from page 36

Switching element non-illuminated

	Contacts	Terminals	Typ-Nr.	Circuit drawing	
Switching element non-illuminated	1 NO	FR	84-8510.0040	3	0.010
		PT 2.8 s	84-8510.0020	3	0.005



Standard version :

Cable length 300 mm; Plug-in terminal 2.8 x 0.8 mm (solderable)

Other options on request :

Customisation of cable and connectors

For IP 67 back protection, cable version only, use blind plug Typ-Nr. 84-900

Contacts: NO = Normally open

Terminals: FR = Flat ribbon cable, PT 2.8 s = Plug-in terminal 2.8 mm (solderable)

Circuit drawing from page 36

Switching element illuminative with PCB terminal

The customer has to decide what series resistor shall be used to the LED

	Contacts	Terminals	Typ-Nr.	Component layout	Technical drawing	Circuit drawing	
Switching element illuminative with PCB terminal	1 NO	P	92-851.342	4	13	11	0.001



Illumination and mounting flange to be ordered separately

Contacts: NO = Normally open

Terminals: P = PCB terminal

Component layout from page 27, Technical drawing from page 29, Circuit drawing from page 36

Illumination element with PCB terminal

The customer has to decide what series resistor shall be used to the LED

	Terminals	Typ-Nr.	Component layout	Technical drawing	
Illumination element with PCB terminal	P	92-800.042	3	9	0.001



Illumination and mounting flange to be ordered separately

Terminals: P = PCB terminal

Component layout from page 27, Technical drawing from page 29

Mounting flange

	Typ-Nr.	Technical drawing	
Mounting flange for Switching- and Illumination element with PCB terminal	92-960.0	10	0.001



Technical drawing from page 29

Flat receptacle

	Typ-Nr.	
Flat receptacle 2.8 x 0.8 mm	84-9420	0.001



Insulation sleeve

	Typ-Nr.	
Insulation sleeve for Flat receptacles 84-9420	31-929	0.001



Plug

	Typ-Nr.	
Plug	84-900	0.001



for back protection IP 67 of Switching elements and Illumination elements.
2 plugs are nessecary per element.

Illumination

Single-LED

The customer has to decide what series resistor shall be used to the LED

Single-LED	Socket	Light colour	Operating voltage/-current	Typ-Nr.	
Single-LED	T1 Bi-Pin	blue	3.6 VDC, 20 mA	10-2603.3176D	0.001
		green	2.2 VDC, 20 mA	10-2602.3175D	0.001
		orange	2.2 VDC, 20 mA	10-2602.3173D	0.001
		red	2.2 VDC, 20 mA	10-2602.3172D	0.001
		white	3.6 VDC, 20 mA	10-2603.3179D	0.001
		yellow	2.2 VDC, 20 mA	10-2602.3174D	0.001



Multi-LED

The customer has to decide what series resistor shall be used to the LED

Multi-LED	Socket	Light colour	Operating voltage/-current	Typ-Nr.	
Multi-LED	T1 Bi-Pin	orange	12 VDC, 40 mA	10-5609.3173D	0.001
			6 VDC, 40 mA	10-5606.3243D	0.001
		red	12 VDC, 40 mA	10-5609.3172D	0.001
			6 VDC, 40 mA	10-5606.3242D	0.001
		yellow	12 VDC, 40 mA	10-5609.3174D	0.001
			6 VDC, 40 mA	10-5606.3244D	0.001



Emergency-stop pushbutton

Emergency-stop label

front panel thickness 3 mm max.

Emergency-stop label	Marking	Typ-Nr.	
60 mm dia., yellow, Mounting hole size 22.5 mm dia.	ARRET D'URGENCE	704.963.7	0.011
	EMERGENCY STOP	704.963.6	0.011
	NOT AUS	704.963.5	0.011
90 mm dia., yellow, Mounting hole size 22.5 mm dia.	EMERGENCY STOP	704.963.1	0.011
	NOT AUS	704.963.0	0.011



Emergency-stop protective shroud

Front panel thickness 1 ... 3 mm

	Marking	Typ-Nr.	Technical drawing	
Emergency-stop protective shroud 45 mm dia., IP 40, mounting hole 22.5 mm dia., with anti-twist device	without	84-909	12	0.021
50 mm dia., mounting hole 22.5 mm dia., with anti-twist device	EMERGENCY STOP	84-902B		0.006
	NOT - AUS	84-902A		0.006
	without	84-902		0.006



Please note: By using the protective shroud Typ-Nr. 84-909 the E-stop or Stop-Switch has to be mounted twisted by 180°. Consult the dimensional drawing therefore.
Technical drawing from page 29

Fixing nut

	Fixing nut	Typ-Nr.	
Fixing nut 28 mm dia.	Plastic black	84-908	0.002
30 mm dia., standard delivery	Plastic black	84-905	0.002



Emergency-stop enclosures

Bottom grey similar RAL 7035; cover lead-sealable, yellow similar RAL 1004

	Dimension	Typ-Nr.	Technical drawing	
Emergency-stop enclosures with mounting hole 22.5 mm dia., with anti-twist device	L 65 mm, W 65 mm, H 57 mm	84-910	11	0.099



Openings for cable gland M16 or M20
Protection class IP 66
Technical drawing from page 29

Cable gland

	Typ-Nr.	
Cable gland M16, Plastic grey	61-9481.6	0.007
M20, Plastic grey	704.945.6	0.011



with traction relief; protection degree IP 68

Stop request pushbutton

Housing, pole mounting 35 mm dia.

	Housing	Colour	Typ-Nr.	Technical drawing	
Housing, pole mounting 35 mm dia.	Plastic blue	RAL 5017 traffic blue	84-9500.6A	16	0.035
	Plastic grey	RAL 7016	84-9500.8	16	0.035
	Plastic yellow	RAL 1023	84-9500.4	16	0.035



Screws are not contained in the scope of supply
 Technical drawing from page 29

Housing, pole mounting 38 mm dia.

	Housing	Colour	Typ-Nr.	Technical drawing	
Housing, pole mounting 38 mm dia.	Plastic grey	RAL 7016	84-9600.8	17	0.030
	Plastic yellow	RAL 1023	84-9600.4	17	0.030



Screws are not contained in the scope of supply
 Technical drawing from page 29

Adaptor, reducing to 30 mm dia.

	Housing	Colour	Typ-Nr.	Technical drawing	
Adaptor, reducing to 30 mm dia. for housing, pole mounting 35 mm dia.	Plastic grey	RAL 7016	84-9700.8	20	0.024
	Plastic yellow	RAL 1023	84-9700.4	20	0.024



Technical drawing from page 29

Adaptor, reducing to 25 mm dia.

	Housing	Colour	Typ-Nr.	Technical drawing	
Adaptor, reducing to 25 mm dia. for housing, pole mounting 35 mm dia.	Plastic grey	RAL 7016	84-9300.8	19	0.008
	Plastic yellow	RAL 1023	84-9300.4	19	0.008



Technical drawing from page 29

Housing, wall mounting

	Housing	Colour	Typ-Nr.	Technical drawing	
Housing, wall mounting	Plastic grey	RAL 7016	84-9800.8	18	0.024
	Plastic yellow	RAL 1023	84-9800.4	18	0.024



Screws are not contained in the scope of supply
Technical drawing from page 29

Assembling

Lens remover

	Typ-Nr.	
Lens remover	61-9730.0	0.011



Mounting tool

	Typ-Nr.	
Mounting tool for tightening or loosening of Emergency-stop and Stop-Switch fixing nut	84-996	0.014
for tightening or loosening of Fixing nut, Indicator and Pushbutton	84-997	0.027

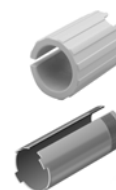

Dismantling tool

	Typ-Nr.	
Dismantling tool for actuator dismantling of switching- and illumination element and mounting flange	84-998	0.002



Stop-Switch fixing nut

	Fixing nut	Typ-Nr.	
Stop-Switch fixing nut 28 mm dia.	Plastic black	84-908	0.002
30 mm dia., standard delivery	Plastic black	84-905	0.002



Stop-Switch enclosures

Grey similar RAL 7035; cover lead-sealable

	Dimension	Typ-Nr.	Technical drawing	
Stop-Switch enclosures with mounting hole 1 x 22.5 mm dia., with anti-twist device	L 94 mm, W 94 mm, H 81 mm	704.945.1	3	0.211
with mounting hole 2 x 22.5 mm dia., with anti-twist device	L 130 mm, W 94 mm, H 81 mm	704.945.2	4	0.251
with mounting hole 3 x 22.5 mm dia., with anti-twist device	L 180 mm, W 94 mm, H 81 mm	704.945.3	5	0.313
with mounting hole 4 x 22.5 mm dia., with anti-twist device	L 180 mm, W 182 mm, H 110 mm	704.945.4	6	0.572
with mounting hole 6 x 22.5 mm dia., with anti-twist device	L 180 mm, W 182 mm, H 110 mm	704.945.5	7	0.568



Openings for cable gland M16 or M20

Protection class IP 66

Technical drawing from page 29

Cable gland

	Typ-Nr.	
Cable gland M16, Plastic grey	61-9481.6	0.007
M20, Plastic grey	704.945.6	0.011



with traction relief; protection degree IP 68

Emergency-stop

Switching system

The double-break switching system can be supplied for the following switching functions :

1 Normally closed, 2 Normally closed, 1 Normally closed + 1 Normally open.

The Normally closed contacts have forced opening according to EN IEC 60947-5-1

Material

Connection cable

Polyvinylchloride (PVC), operating temperature up to +65 °C

Mushroom-head cap

Polybutylenterephthalate (PBT), as per UL 94 V0 (red items)

Actuator housing

Polyamide (PA 66), as per UL 94 V0, Flat ribbon cable-cover
Polyamide (PA 6.6), as per UL 94 V0

Material of contact

Silver alloy gold plated

Mechanical characteristics

Front panel thickness

Standard 1 ... 4 mm
with E-stop protective shroud Typ-Nr. 84-902 1 ... 3 mm

Mounting hole

22.5 mm dia. as per EN IEC 60947-5-1 with anti-twist device

Terminals

Soldering terminals 2.8 x 0.5 mm (solderable), CuSn6 tin-plated
Flat ribbon cable 2-, 4-, or 6-poles 0.35 mm² (AWG 22)

Tightening torque

Fixing nut 80 Ncm

Actuating force

22 N ±4 N

Actuating travel

approx. 4 mm to release the internal operation part

Mechanical lifetime

≥50.000 cycles of operations

Electrical characteristics

Standards

The devices comply with : EN IEC 60947-5-1, EN IEC 60947-5-5 (Emergency-stop), DIN EN ISO 13850, EN IEC 60204

Illumination

LED red with pole reversal, constant current source

Operation Voltage 5 VDC ... 30 VDC
Current consumption 9.7 mA ... 12.4 mA

Rated Operational Voltage U_e

250 VAC, as per EN IEC 60947-1

Rated Insulation Voltage U_i

250 V, as per EN IEC 60947-1

Rated Impulse Withstand Voltage U_{imp}

2.5 kV, as per EN IEC 60947-1

Contact resistance

New state ≤ 50 mΩ, as per DIN IEC 60512-2-3

Isolation resistance

>10¹¹ Ω between the open contacts at 500 VDC, as per DIN IEC 60512-2-10

Electrical life

≥50 000 cycles of operations (inductive cosφ 0.4), as per EN IEC 60947-5-1

Voltage	120 VAC	240 VAC	125 VDC	250 VDC
Current	3 A	1.5 A	0.55 A	0.27 A

Reduced load ≥50'000 cycles of operations (resistive)

Voltage	1 VAC/DC	42 VAC/DC
Current	100 mA	200 mA

Conventional free air thermal current I_{th}

5 A, as per EN IEC 60947-5-1

the maximum current in continuous operation and at ambient temperature must not exceed the quoted maximum values.

Switch rating

Switch rating AC with silver contact (gold plated), service category AC-15, as per EN IEC 60947-5-1

Voltage	120 VAC	240 VAC
Current	3 A	1.5 A

Switch rating DC for silver contact (gold plated), service category DC-13, as per EN IEC 60947-5-1 (inductive)

Voltage	12 VDC	24 VDC	48 VDC	60 VDC	125 VDC	250 VDC
Current	5 A	4 A	2.1 A	1.7 A	0.55 A	0.27 A

Recommended minimum operational data

Silver contacts (gold plated)

Voltage	1 VAC/DC
Current	1 mA

Electric strength

500 VAC, 50 Hz, 1 min, as per DIN IEC 60512-2

Rated conditional short-circuit current

1000 A, type of short-circuit unit 6 A gG, as per EN IEC 60947-5-1

Protection class

Class II, as per EN IEC 60947-5

Overvoltage category

II, as per EN IEC 60947-1

Degree of pollution

3, as per EN IEC 60947-1

Environmental conditions

Storage temperature

-25 °C ... +80 °C

Operating temperature

-25 °C ... +65 °C

Front protection

IP 65, as per EN IEC 60529

Shock resistance

(semi-sinusoidal)
max. 150 m/s², pulse width 11 ms, 3-axis, as per
EN IEC 60068-2-27

Vibration resistance

(sinusoidal)
max. 50 m/s² at 10 Hz ... 500 Hz, 10 cycles, 3-axis, as per
EN IEC 60068-2-6

Climate resistance

Damp heat, cyclic
96 hours, +25 °C / 97 % , +55 °C / 93 % relative humidity, as per
EN IEC 60068-2-30

Damp heat, steady
56 days, +40 °C / 93 % relative humidity, as per EN IEC 60068-2-78

Dry heat
96 hours, +70 °C, as per EN IEC 60068-2-2

Low temperature
96 hours, -40 °C, as per EN IEC 60068-2-1

Saline mist
96 Stunden, +35 °C in chemical solution NaCl, as per
EN IEC 60068-2-11

Approvals

CE
SEV
UL
RoHS compliant

Switching element illuminated pushbutton

Switching system

Short-travel switching system with 2 independent contact points
and tactile operation.
Guarantees reliable switching even of very light loads.
Fitted with 1 normally open contact.

Material

Connection cable

Polyvinylchloride (PVC), short-time heat-resistant up to 105 °C

Material of contact

Silver alloy gold plated

Switching element

Thermoplastic polyester (PET, PBT), as per UL 94 V0 and
Polyacetale (POM), as per UL 94 HB

Mechanical characteristics

Terminals

Plug-in terminals 2.8 x 0.8 mm (solderable)
Flat ribbon cable 0.5 mm²
PCB terminal

Actuating force

4.0 N ±0.2 N (measured at the lens)

Actuating travel

~0.5 mm

Rebound time

≤1 ms

Resistance to heat of soldering

260 °C, 5 s (PCB assembly)
350 °C, 10 s (when using a soldering iron)
as per EN IEC 60068-2-20

Mechanical lifetime

≥1 million cycles of operations

Electrical characteristics

Illumination

Single-Chip or Multi-Chip LED, green, orange, red, yellow, white
and blue

Operation Voltage	12 VDC	24 VDC
Current consumption	40 mA	20 mA

Contact resistance

Starting value (initial) ≤100 mΩ, as per DIN IEC 60512-2

Isolation resistance

≥1 G Ω between all terminals at 100 VDC, as per DIN IEC 60512-2

Electrical life

as per EN IEC 60512-5

5 million	cycles of operation	24 VAC, 50 mA at 480 Ω
5 million	cycles of operation	24 VAC, 100 mA at 240 Ω
2 million	cycles of operation	42 VAC, 50 mA at 840 Ω
2 million	cycles of operation	42 VAC, 100 mA at 420 Ω
300 000	cycles of operation	42 VAC, 100 mA at cosφ 0,4
250 000	cycles of operation	42 VAC, 200 mA at cosφ 0,395

1 million	cycles of operation	12 VDC, 250 mA at 48 Ω
1 million	cycles of operation	24 VDC, 50 mA at 480 Ω
1 million	cycles of operation	24 VDC, 100 mA at 240 Ω
5 million	cycles of operation	42 VDC, 25 mA at 1680 Ω
1.5 million	cycles of operation	42 VDC, 50 mA at 840 Ω
100 000	cycles of operation	42 VDC, 100 mA at 420 Ω

500 000	cycles of operation	24 VDC, 200 mA at L/R=30 ms
300 000	cycles of operation	42 VDC, 100 mA at L/R=30 ms
100 000	cycles of operation	42 VDC, 200 mA at L/R=30 ms

Switch rating

Voltage	50 mVAC/DC ... 42 VAC/DC
Current	10 uA ... 100 mA
Power	max. 2 W

Electric strength

500 VAC, 50 Hz, 1 min, as per DIN IEC 60512-2

Environmental conditions

Storage temperature

-40 °C ... +85 °C

Operating temperature

-25 °C ... +70 °C

Protection degree

For IP 67 back protection, cable version only, use blind plug
Typ-Nr. 84-900

Shock resistance

(semi-sinusoidal)
max. 100 m/s², pulse width 11 ms, 3-axis, as per
EN IEC 60068-2-27

Vibration resistance

(sinusoidal)

max. 50 m/s² at 10 Hz ... 500 Hz, 10 cycles, 3-axis, as per EN IEC 60068-2-6

Actuator

Material

Lens

Polycarbonate (PC), as per UL 94 V2 or Aluminium anodised

Actuator housing

Polyetherimid (PEI), as per UL 94 V0 or Aluminium anodised

Mechanical characteristics

Mounting hole

22.5 mm dia. and 30.5 mm dia.

Tightening torque

Fixing nut max. 80 Ncm

Actuating force

4.0 N ±0.2 N (measured at the lens)

Actuating travel

Total switching travel 1.2 mm

Mechanical lifetime

≥1 million cycles of operations

Electrical characteristics

Electrostatic breakdown value

Plastic case ≥15 kV

Aluminium case ≥5 kV

as per IEC 61000-4-2, mounted in plastic front panel

Environmental conditions

Storage temperature

-40 °C ... +85 °C

Operating temperature

-25 °C ... +70 °C

Front protection

IP 67, IP 65 and IP40, as per EN IEC 60529

Climate resistance

Damp heat, cyclic

96 hours, +25 °C / 97 %, +55 °C / 93 % relative humidity, as per EN IEC 60068-2-30

Damp heat, state

56 days, +40 °C / 93 % relative humidity, as per EN IEC 60068-2-78

Rapid change of temperature

100 cycles, -40 °C ... +80 °C, as per EN IEC 60068-2-14

Component layout

1 Emergency-stop pushbutton, foolproof EN IEC 60947-5-5, complete page 9 | Stop-Switch grey, complete page 10

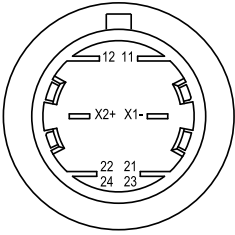

2 Emergency-stop pushbutton, foolproof EN IEC 60947-5-5, complete page 9 | Stop-Switch grey, complete page 10

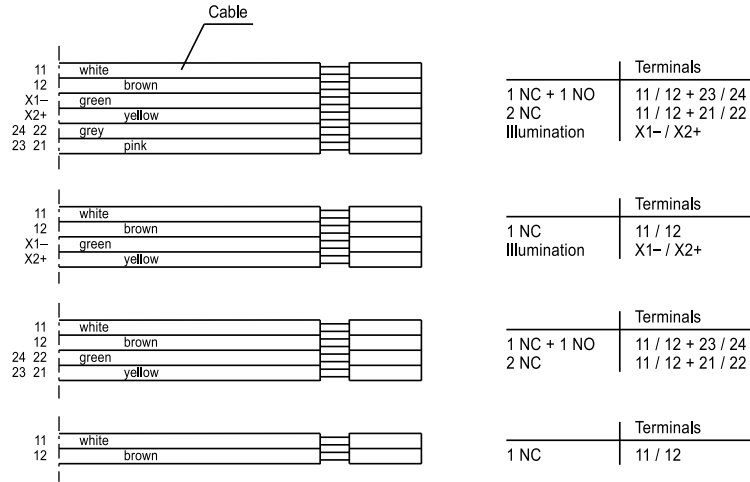
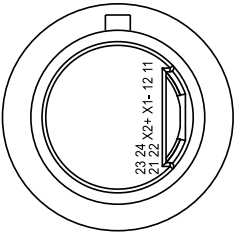

3 Illumination element with PCB terminal page 18

Drilling plan (Elementside)

- A Fixing holes for mounting flange
- B Holes for LED
- C Holes for centering pins

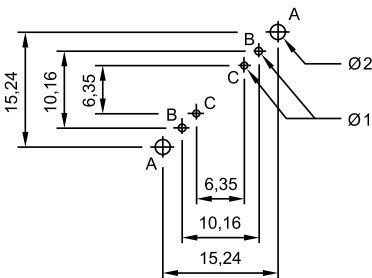

Libraries for the PCB layout-system p-cad 200X see : www.pcad.com/en/library Third-party Libraries

4 Switching element illuminative with PCB terminal page 17

Drilling plan (Elementside)

- A Fixing holes for mounting flange
- B Fixing holes for LED
- C Holes for contact pins
pad max. 2.5 mm dia.
through-connection recommended

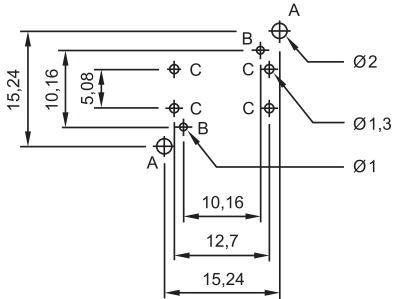

Libraries for the PCB layout-system p-cad 200X see : www.pcad.com/en/library Third-party Libraries

Mounting dimensions

1 Indicator actuator, flush mounting page 11 | Illuminated pushbutton actuator, flush mounting page 11

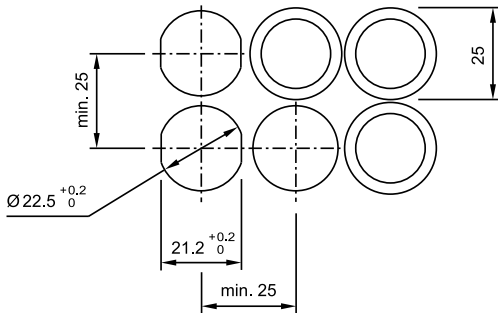

Hole spacing 31 mm min. by using blind plug 704.960.4

2 Emergency-stop pushbutton, foolproof EN IEC 60947-5-5, complete page 9 | Stop-Switch grey, complete page 10

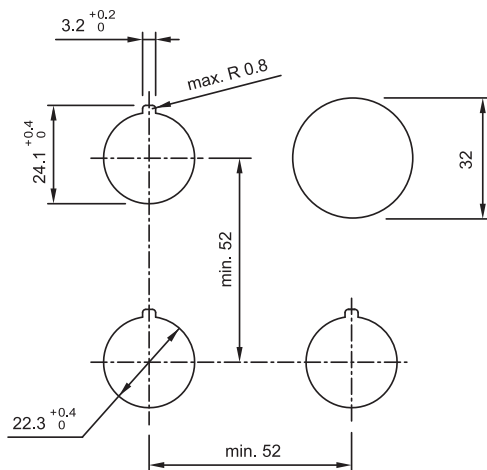

3 Illuminated pushbutton actuator, flush mounting page 11

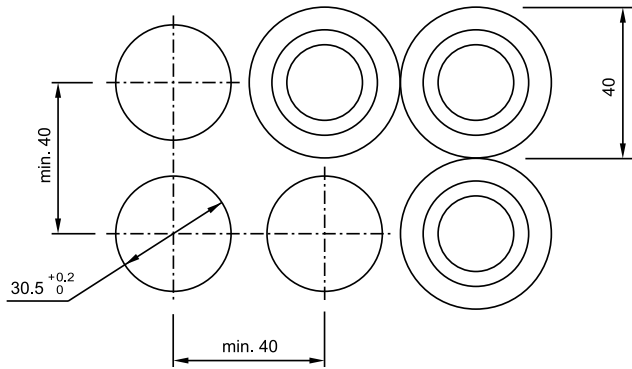

Technical drawing

1 Blind plug page 14

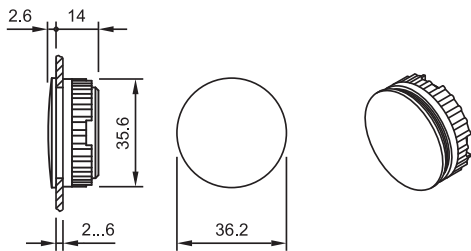

2 Blind plug page 14

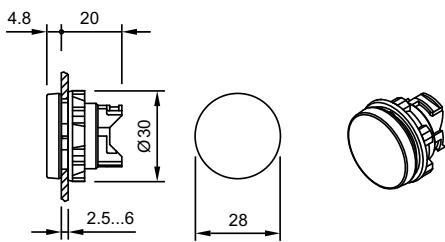

3 Stop-Switch enclosures page 23

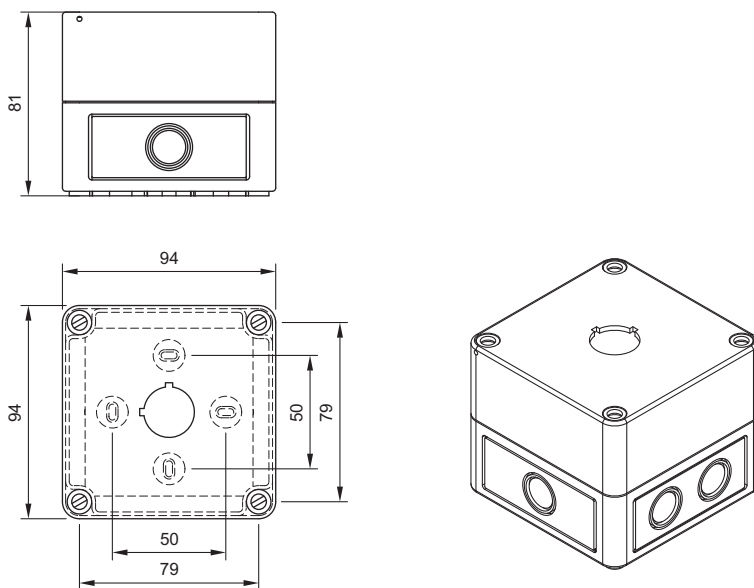

4 Stop-Switch enclosures page 23

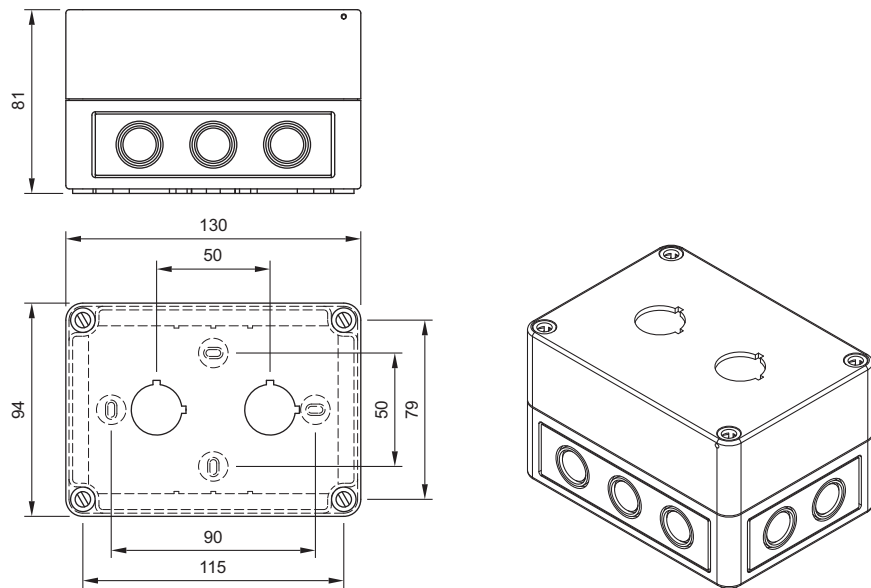

5 Stop-Switch enclosures page 23

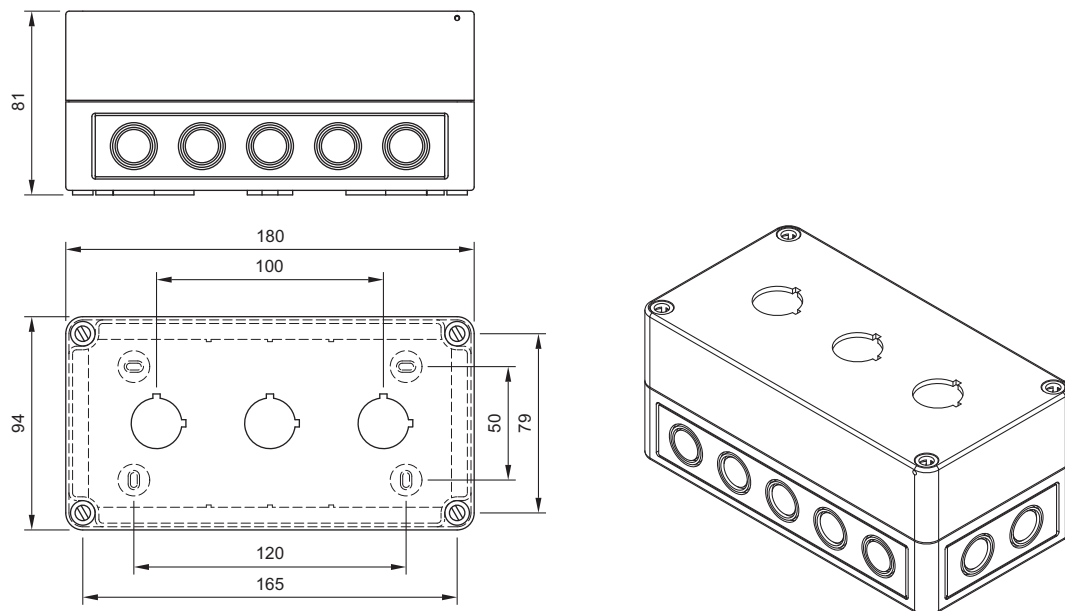

6 Stop-Switch enclosures page 23

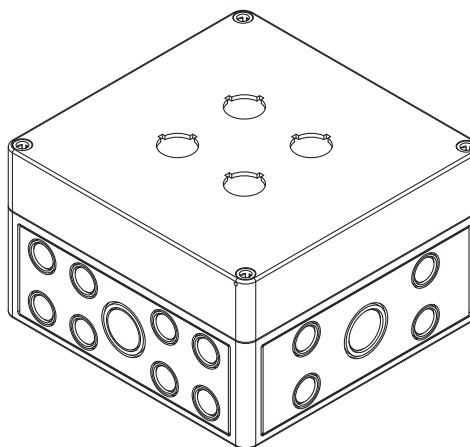
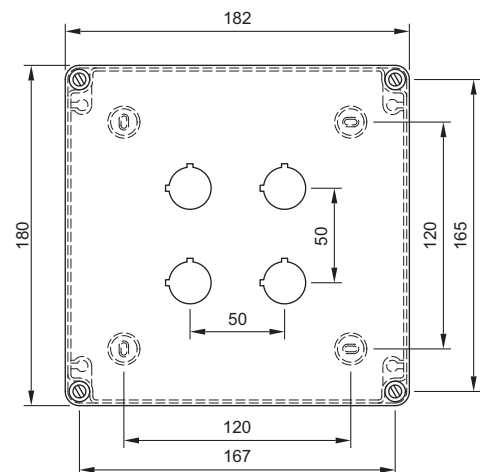
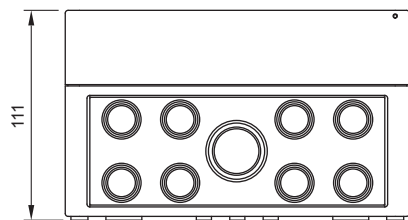

7 Stop-Switch enclosures page 23

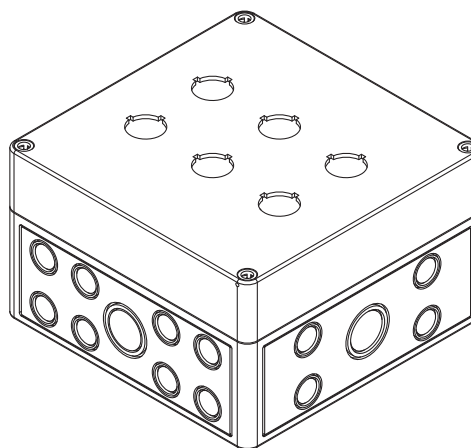
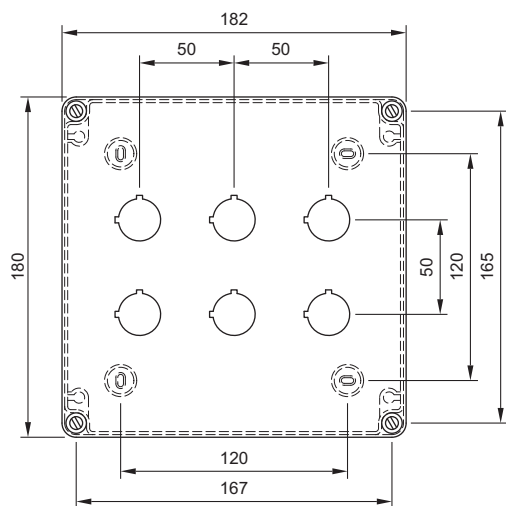
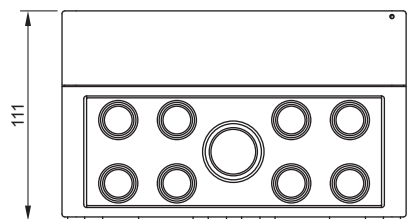

8 Legend frame page 14

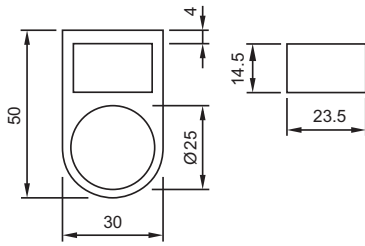

9 Illumination element with PCB terminal page 18

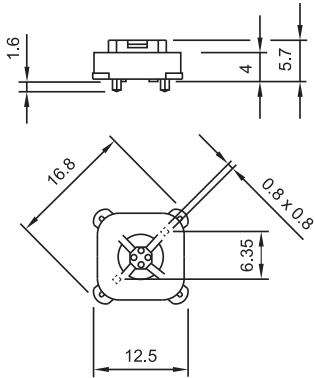

10 Mounting flange page 18

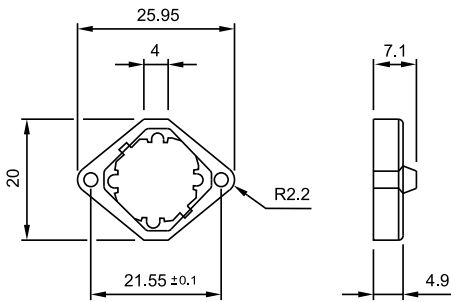

11 Emergency-stop enclosures page 20

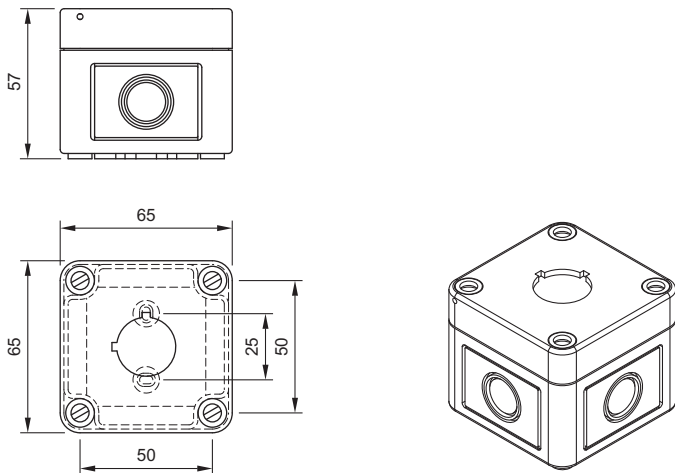

12 Emergency-stop protective shroud page 20

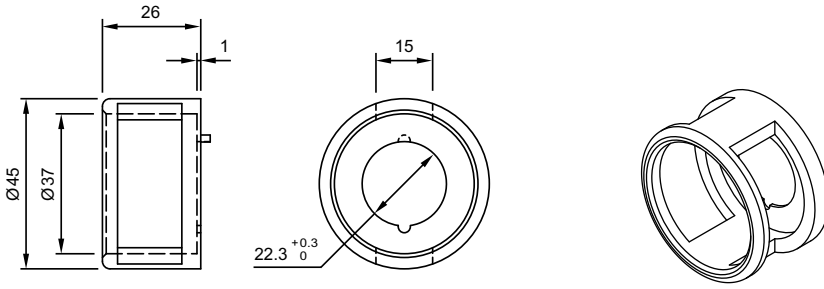

13 Switching element illuminative with PCB terminal page 17

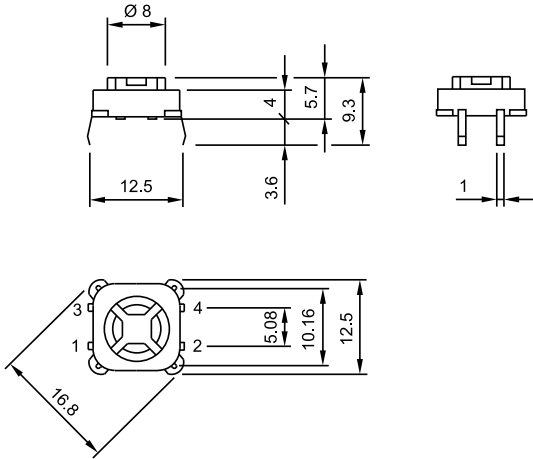

14 Indicator actuator, flush mounting page 11 | Illuminated pushbutton actuator, flush mounting page 11

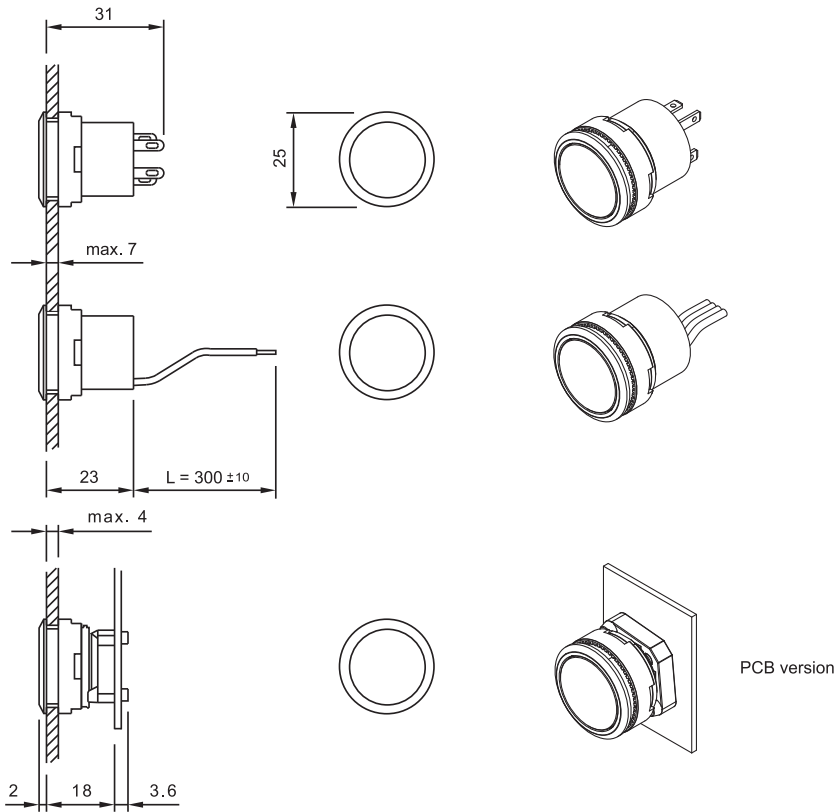

15 Emergency-stop pushbutton, foolproof EN IEC 60947-5-5, complete page 9 | Stop-Switch grey, complete page 10

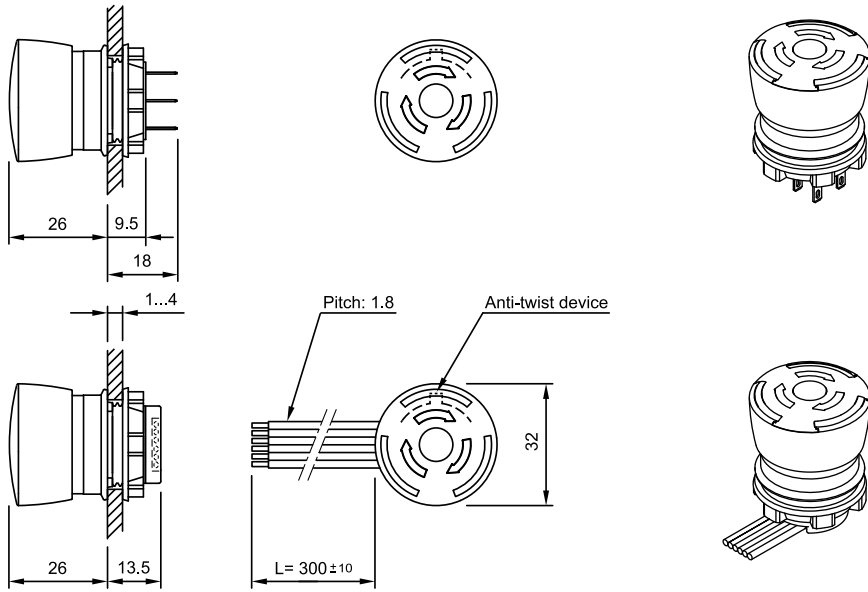

16 Housing, pole mounting 35 mm dia. page 21

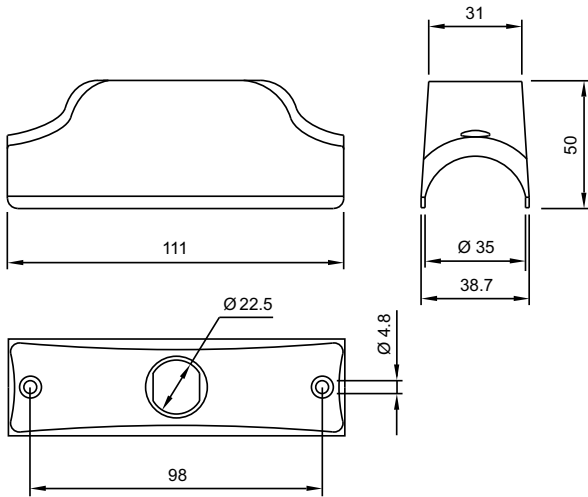

17 Housing, pole mounting 38 mm dia. page 21

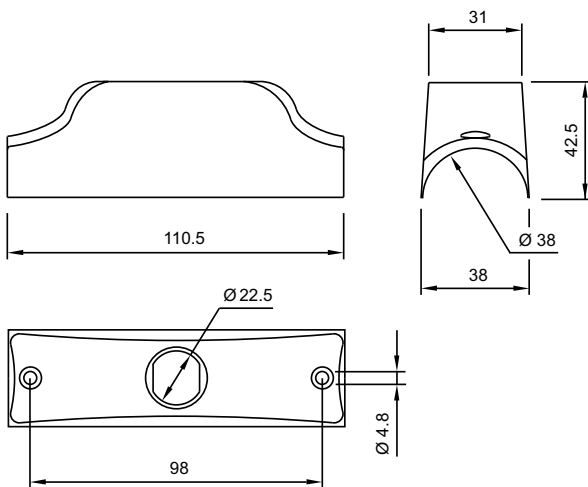

18 Housing, wall mounting page 22

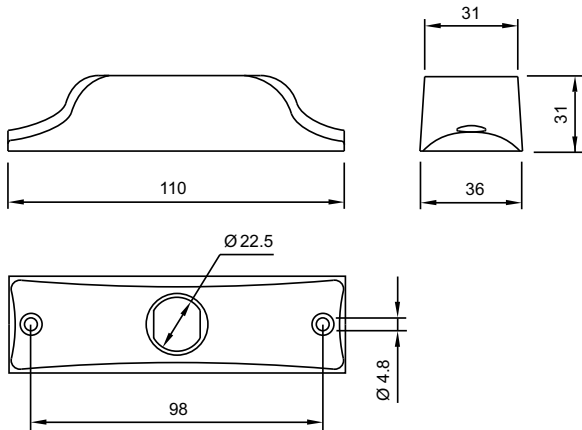

19 Adaptor, reducing to 25 mm dia. page 22

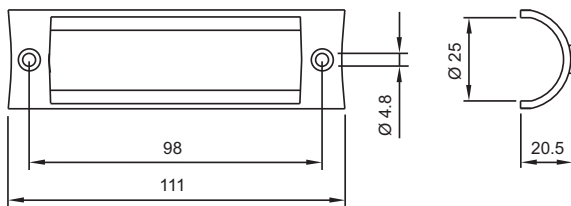

20 Adaptor, reducing to 30 mm dia. page 21

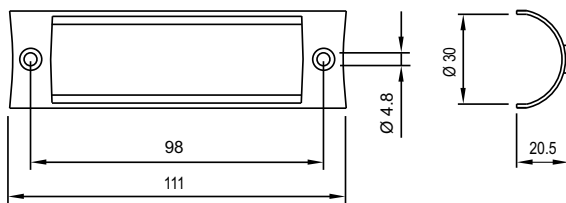

21 Illuminated pushbutton actuator, flush mounting page 11

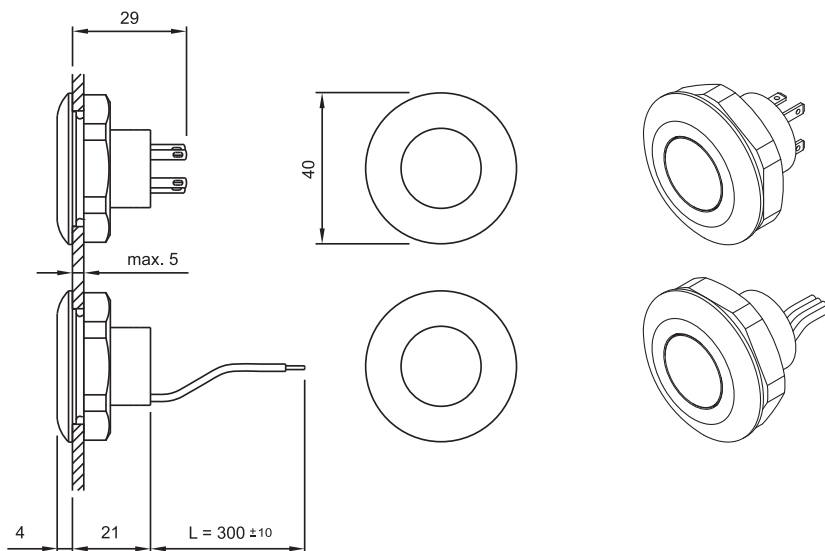

Circuit drawing

1 Illuminated pushbutton actuator, flush mounting page 11



2 Illumination element page 15



3 Switching element non-illuminated page 17



4 Switching element illuminated page 16 | **Switching element Bi-Color illumination** page 17

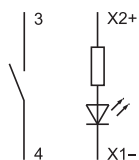

5 Emergency-stop pushbutton, foolproof EN IEC 60947-5-5, complete page 9 | **Stop-Switch grey, complete** page 10

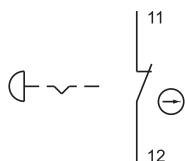

6 Emergency-stop pushbutton, foolproof EN IEC 60947-5-5, complete page 9 | **Stop-Switch grey, complete** page 10

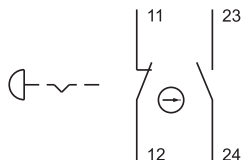

7 Emergency-stop pushbutton, foolproof EN IEC 60947-5-5, complete page 9 | **Stop-Switch grey, complete** page 10

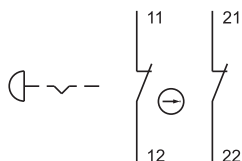

8 Emergency-stop pushbutton, foolproof EN IEC 60947-5-5, complete page 9 | **Stop-Switch grey, complete** page 10

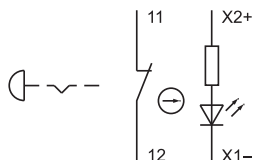

9 Emergency-stop pushbutton, foolproof EN IEC 60947-5-5, complete page 9 | Stop-Switch grey, complete page 10

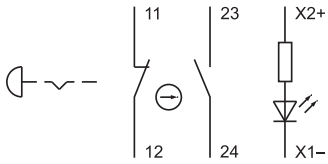

10 Emergency-stop pushbutton, foolproof EN IEC 60947-5-5, complete page 9 | Stop-Switch grey, complete page 10

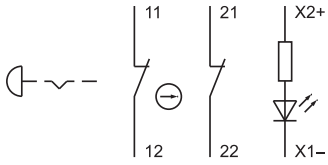

11 Switching element illuminative with PCB terminal page 17

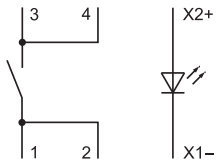

Index from Typ-Nr.

Typ-Nr.	Page	Typ-Nr.	Page	Typ-Nr.	Page
10-2602.3172D	19	84-5140.0020	9	84-7211.400	13
10-2602.3173D	19	84-5140.0040	9	84-7211.500	13
10-2602.3174D	19	84-5141.2B20	9	84-7211.600	13
10-2602.3175D	19	84-5141.2B40	9	84-7211.800	13
10-2603.3176D	19	84-6020.0020	10	84-7215.000	13
10-2603.3179D	19	84-6020.0040	10	84-7215.200	13
10-5606.3242D	19	84-6021.2B20	10	84-7215.400	13
10-5606.3243D	19	84-6021.2B40	10	84-7215.500	13
10-5606.3244D	19	84-6030.0020	10	84-7215.600	13
10-5609.3172D	19	84-6030.0040	10	84-7215.800	13
10-5609.3173D	19	84-6031.2B20	10	84-8001.2620	15
10-5609.3174D	19	84-6031.2B40	10	84-8001.2640	15
31-929	18	84-6040.0020	10	84-8001.3620	15
61-9481.6	20	84-6040.0040	10	84-8001.3640	15
61-9481.6	23	84-6041.2B20	10	84-8001.4620	15
61-9707.7	12	84-6041.2B40	10	84-8001.4640	15
61-9730.0	22	84-7111.200	12	84-8001.5620	15
61-9980.0	14	84-7111.300	12	84-8001.5640	15
704.945.1	23	84-7111.400	12	84-8001.6620	15
704.945.2	23	84-7111.500	12	84-8001.6640	15
704.945.3	23	84-7111.600	12	84-8001.9320	15
704.945.4	23	84-7111.700	12	84-8001.9340	15
704.945.5	23	84-7115.200	12	84-8001.9620	15
704.945.6	20	84-7115.300	12	84-8001.9640	15
704.945.6	23	84-7115.400	12	84-8002.2320	15
704.960.4	14	84-7115.500	12	84-8002.2340	15
704.963.0	19	84-7115.600	12	84-8002.2620	15
704.963.1	19	84-7115.700	12	84-8002.2640	15
704.963.5	19	84-7121.000	12	84-8002.3320	15
704.963.6	19	84-7121.800	12	84-8002.3340	15
704.963.7	19	84-7124.000A	13	84-8002.3620	15
704.964.8	14	84-7124.200A	13	84-8002.3640	15
704.968.0	14	84-7124.400A	13	84-8002.4320	15
704.968.1	14	84-7124.500A	13	84-8002.4340	15
84-0090.7	11	84-7124.600A	13	84-8002.4620	15
84-0100.0	11	84-7125.000	12	84-8002.4640	15
84-0200.7	11	84-7125.800	12	84-8002.5320	15
84-1091.7	11	84-7201.000	12	84-8002.5340	15
84-1101.0	11	84-7201.200	12	84-8002.5620	15
84-1201.7	11	84-7201.400	12	84-8002.5640	15
84-1221.7	11	84-7201.500	12	84-8510.0020	17
84-2101.0	11	84-7201.600	12	84-8510.0040	17
84-3100.0	11	84-7201.800	12	84-8511.2620	16
84-5020.0020	9	84-7202.000	12	84-8511.2640	16
84-5020.0040	9	84-7202.200	12	84-8511.3620	16
84-5021.2B20	9	84-7202.400	12	84-8511.3640	16
84-5021.2B40	9	84-7202.500	12	84-8511.4620	16
84-5030.0020	9	84-7202.600	12	84-8511.4640	16
84-5030.0040	9	84-7202.800	12	84-8511.5620	16
84-5031.2B20	9	84-7205.000	12	84-8511.5640	16
84-5031.2B40	9	84-7205.000A	13	84-8511.6620	16
84-5040.0020	9	84-7205.200	12	84-8511.6640	16
84-5040.0040	9	84-7205.200A	13	84-8511.9320	16
84-5041.2B20	9	84-7205.400	12	84-8511.9340	16
84-5041.2B40	9	84-7205.400A	13	84-8511.9620	16
84-5120.0020	9	84-7205.500	12	84-8511.9640	16
84-5120.0040	9	84-7205.500A	13	84-8512.2320	16
84-5121.2B20	9	84-7205.600	12	84-8512.2340	16
84-5121.2B40	9	84-7205.600A	13	84-8512.2620	16
84-5130.0020	9	84-7205.800	12	84-8512.2640	16
84-5130.0040	9	84-7205.800A	13	84-8512.3320	16
84-5131.2B20	9	84-7211.000	13	84-8512.3340	16
84-5131.2B40	9	84-7211.200	13	84-8512.3620	16

Index from Typ-Nr.

<u>Typ-Nr.</u>	<u>Page</u>	<u>Typ-Nr.</u>	<u>Page</u>	<u>Typ-Nr.</u>	<u>Page</u>
84-8512.3640	16				
84-8512.4320	16				
84-8512.4340	16				
84-8512.4620	16				
84-8512.4640	16				
84-8512.5320	16				
84-8512.5340	16				
84-8512.5620	16				
84-8512.5640	16				
84-8512.6620	16				
84-8512.6640	16				
84-8515.8640	17				
84-900	18				
84-902	20				
84-902A	20				
84-902B	20				
84-905	20				
84-905	23				
84-908	20				
84-908	23				
84-909	20				
84-910	20				
84-9103.7	13				
84-9300.4	22				
84-9300.8	22				
84-9420	18				
84-9500.4	21				
84-9500.6A	21				
84-9500.8	21				
84-9600.4	21				
84-9600.8	21				
84-9700.4	21				
84-9700.8	21				
84-9800.4	22				
84-9800.8	22				
84-996	22				
84-997	22				
84-998	22				
92-800.042	18				
92-851.342	17				
92-960.0	18				

	EAO AG Tannwaldstrasse 88 4601 Olten, Switzerland
E-mail	info@eao.com
Website	www.eao.com
	Austria
Phone	+49/201 85 87 0
E-mail	sales.ede@eao.com
	Belgium
Phone	+32/2 456 00 10
E-mail	sales.ebl@eao.com
	China
Phone	+852/27 86 91 41
E-mail	sales.ehk@eao.com
	France
Phone	+33/1 64 43 37 37
E-mail	sales.es@eao.com
	Germany
Phone	+49/201 85 87 0
E-mail	sales.ede@eao.com
	Italy
Phone	+39/035 481 0189
E-mail	sales.eit@eao.com
	Japan
Phone	+81/3 5401 0953
E-mail	sales.esj@eao.com
	Netherlands
Phone	+31/78 653 17 00
E-mail	sales.enl@eao.com
	Sweden
Phone	+46/8 683 86 60
E-mail	sales.esw@eao.com
	Switzerland
Phone	+41/62 388 95 00
E-mail	sales.ech@eao.com
	United Kingdom
Phone	+44/1444 236000
E-mail	sales.euk@eao.com
	USA
Phone	+1/203 877 4577
E-mail	sales.eus@eao.com
	Other Countries
Fax	+41/62 296 21 62
E-mail	info@eao.com
Website	www.eao.com