

THIS DRAWING IS UNPUBLISHED. RELEASED FOR PUBLICATION
 © COPYRIGHT BY TYCO ELECTRONICS CORPORATION. ALL RIGHTS RESERVED.

LOC		DIST		REVISIONS			
P	LTR	DESCRIPTION		DATE	DWN	APVD	
AJ	16	A		REVISED PER OS14-0150-05	10OCT2005	REH JGH	

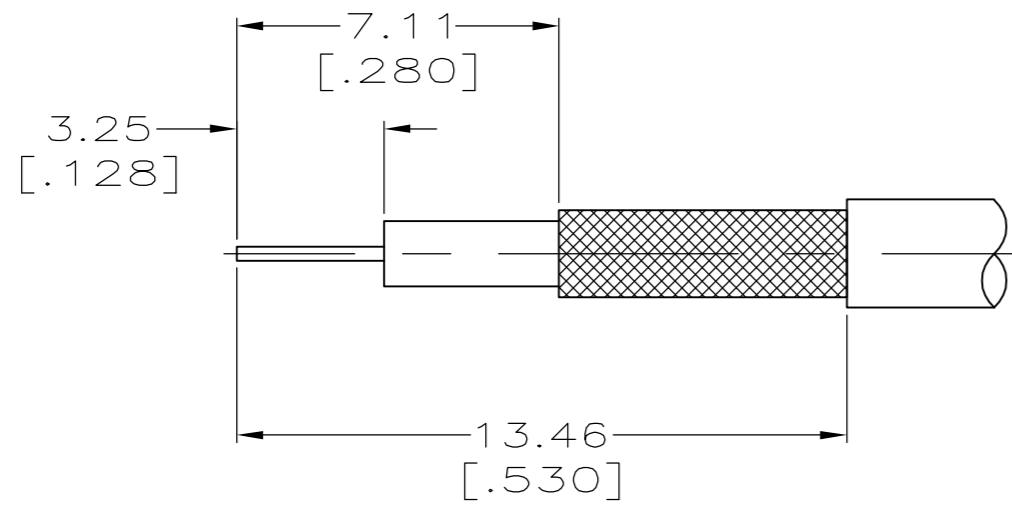

RECOMMENDED STRIP LENGTHS

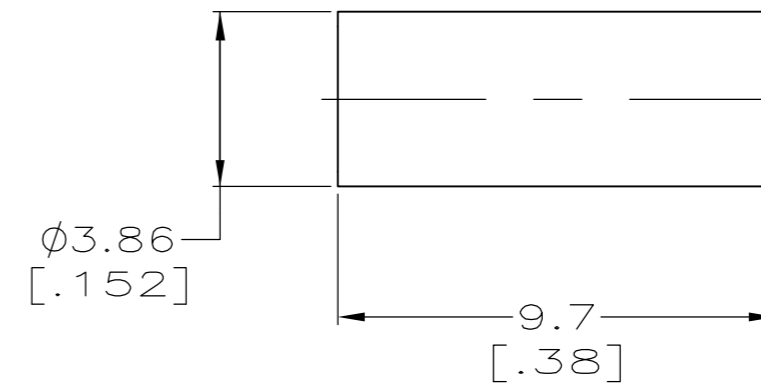
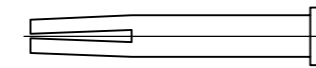
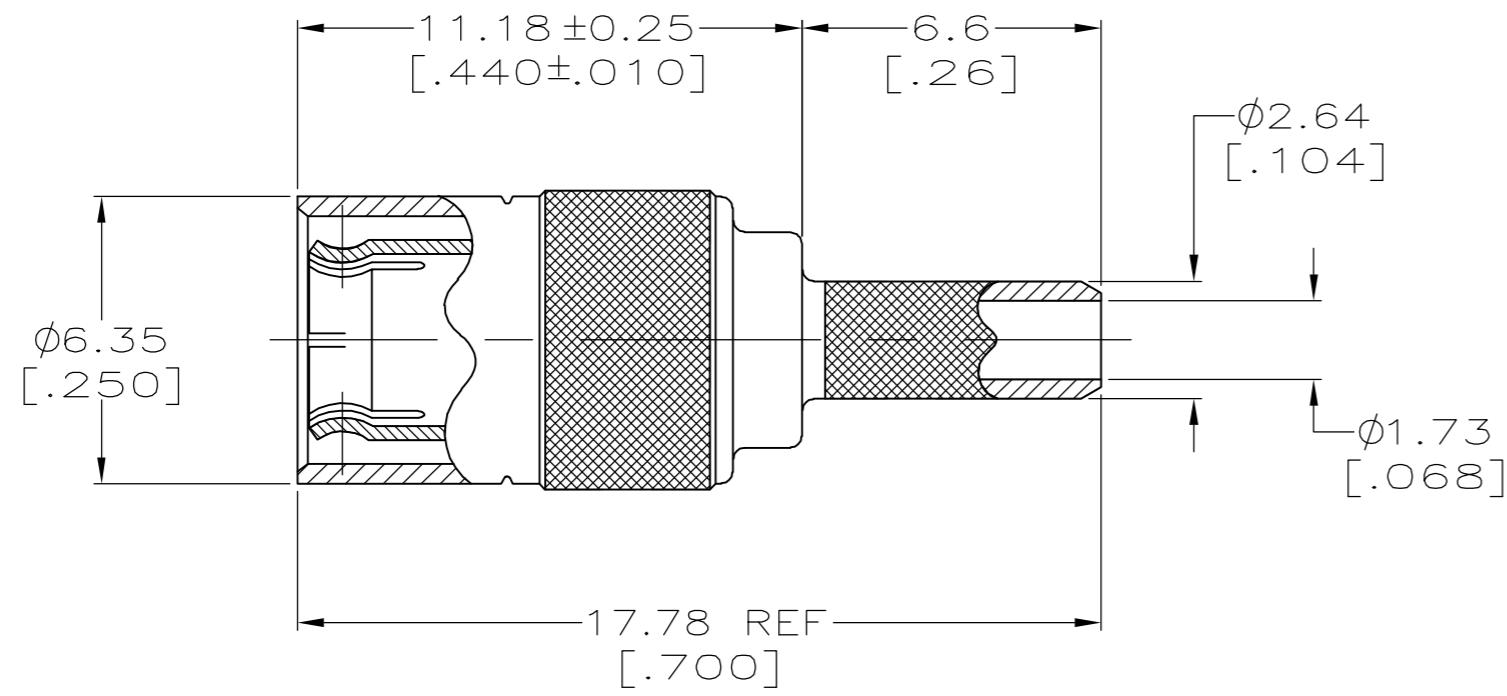

- △ MATERIALS:
 BODY: ZINC PER ASTM-B-86.
 OUTER CONTACT: BERYLLIUM COPPER PER ASTM-B-194.
 CENTER CONTACT: BERYLLIUM COPPER PER ASTM-B-196.
 DIELECTRIC: TEFLON PER ASTM-D-1710.
- △ FINISHES:
 BODY: NICKEL PER QQ-N-290.
 OUTER CONTACT: GOLD PER ASTM-B-488.
 CENTER CONTACT: GOLD PER ASTM-B-488.
- △ FINISHES:
 BODY: NICKEL PER QQ-N-290.
 OUTER CONTACT: NICKEL PER QQ-N-290.
 CENTER CONTACT: GOLD PER ASTM-B-488.
- △ TOOLING INFORMATION:
 CONTACT CRIMP: HAND TOOL M-22520/2-01 WITH DANIELS POSITIONER #K699, USE WITH SELECTOR #4.
 BRAID CRIMP: HAND TOOL M-22520/5-01 WITH DANIELS DIE SET #HX4-1637 (.128 HEX) OR AMP PRO-CRIMPER WITH DIE SET #58483-1, USE POSITION LETTER B.
- 5. SEE INSTRUCTION SHEET 408-2987-12.
- △ TOOLING INFORMATION:
 CONTACT CRIMP: HAND TOOL M-22520/2-01 WITH DANIELS POSITIONER #K699, USE WITH SELECTOR #4.
 BRAID CRIMP: HAND TOOL M-22520/2-01 WITH DANIELS DIE SET #HX4-1637 (.151 HEX) OR AMP PRO-CRIMPER WITH DIE SET #58483-1, USE POSITION LETTER C.
- △ FOR USE WITH RG 179/U CABLE.
- △ FOR USE WITH RD 179/U (DOUBLE-BRAIDED) CABLE.

△8	△6	△3	5415487-3
△7	△4	△3	5415487-2
△7	△4	△2	5415487-1
CABLE	TOOLING	FINISH	PART NUMBER

THIS DRAWING IS A CONTROLLED DOCUMENT.		DWN J. HAVENER 01APR2005	Tyco Electronics Corporation Harrisburg, PA 17105-3608	
DIMENSIONS: mm [INCHES]		CHK J. HAVENER 01APR2005		
TOLERANCES UNLESS OTHERWISE SPECIFIED:		APVD J. HAVENER 01APR2005	NAME CABLE PLUG 75 OHM, MINI-SMB	
0 PLC ± - 1 PLC ± 0.3 [.01] 2 PLC ± 0.13 [.005] 3 PLC ± - 4 PLC ± - ANGLES ± - FINISH		PRODUCT SPEC -	RESTRICTED TO -	
MATERIAL △1		APPLICATION SPEC -	SIZE A2	CAGE CODE 00779
FINISH △2 △3		WEIGHT -	DRAWING NO C=5415487	
CUSTOMER DRAWING		SCALE 6:1		SHEET 1 of 1
		REV A		