



General Specifications

- Motor Protection:** Thermal Protect
- Motor Structure:** Shaded Pole Induction Motor
- Insulation Resistance:** 100M Ω or over with a DC500V Megger
- Dielectric Withstand Voltage:** AC 1800V 3s
- Allowable Ambient Temperature Range:**
 - 10°C ~ +60°C (Operating)
 - 40°C ~ +70°C (Storage)
 - (non-condensing environment)

Expected Life

Failure Rate: 10%
25°C 50,000 Hours

Outline

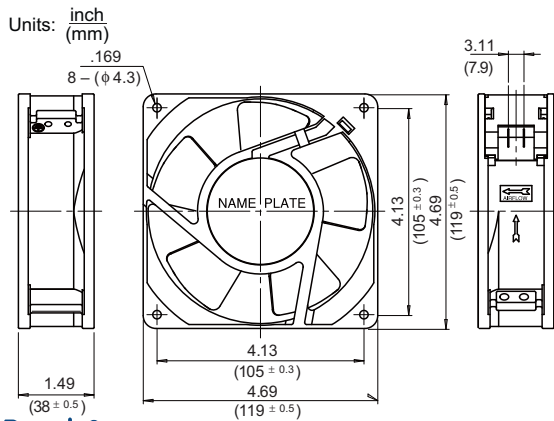

Panel Cut-outs

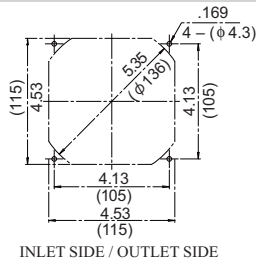

Characteristic Curves

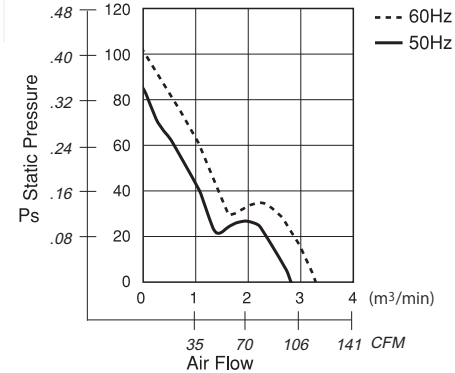

Material

- Casing : Aluminum
- Impeller : Steel
- Bearing : Ball Bearings
- Terminal: Faston #110 or Equiv

Specifications

MODEL	Rated Voltage	Frequency	Starting Voltage	Current	Input Power	Speed	Max. Air Flow	Max. Static Pressure	Noise	Mass
	(V)	(Hz)	(V)	(A) ^{*1}	(W)+10/-20%	(min) ⁻¹ *3	(CFM) ^{*2} (m³/min) ^{*2}	(in H ₂ O) ^{*2} (Pa) ^{*2}	(dB) ^{*2}	(g)
4715TS-10T-B5A-B00	100	50	65	0.45	20.0	2600	98.84 2.80	.352 88.0	46.0	610
		60		0.34	17.0	3100	116.49 3.30	.400 100.0	50.0	
4715TS-12T-B5A-A00	115	50	75	0.39	21.0	2600	98.84 2.80	.352 88.0	46.0	
		60		0.30	17.0	3100	116.49 3.30	.400 100.0	50.0	
4715TS-20T-B5A-B00	200	50	130	0.22	21.0	2600	98.84 2.80	.352 88.0	46.0	
		60		0.17	17.0	3100	116.49 3.30	.400 100.0	50.0	
4715TS-22T-B5A-B00	220	50	145	0.20	20.0	2600	98.84 2.80	.352 88.0	46.0	
		60		0.15	17.0	3100	116.49 3.30	.400 100.0	50.0	
4715TS-23T-B5A-A00	230	50	175	0.19	21.0	2600	98.84 2.80	.352 88.0	46.0	
		60		0.14	17.0	3100	116.49 3.30	.400 100.0	50.0	
4715TS-24T-B5A-A00	240	50	175	0.18	20.0	2600	98.84 2.80	.352 88.0	46.0	
		60		0.14	17.0	3100	116.49 3.30	.400 100.0	50.0	

Rotation: Counterclockwise as seen from the label side.
Airflow Outlet: Label side

*1: Maximum Values in Free Air
*2: Average Values in Free Air

*3: Minimum Values in Free Air