

**RIGHT ANGLE PLUG CRIMP TYPE**  
**FOR CABLE 11/50D**

**R161A.186.000**

Series : ECO N

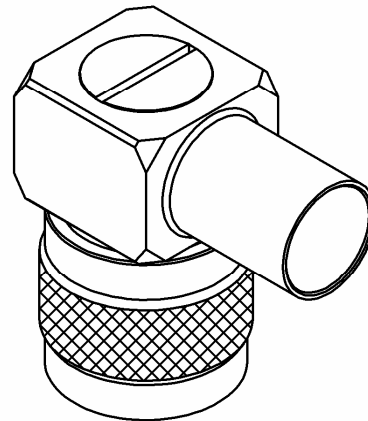
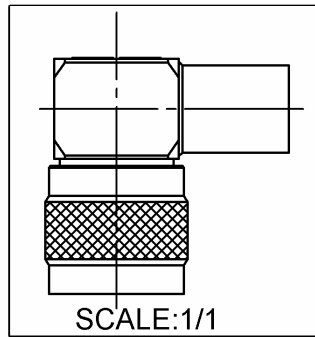
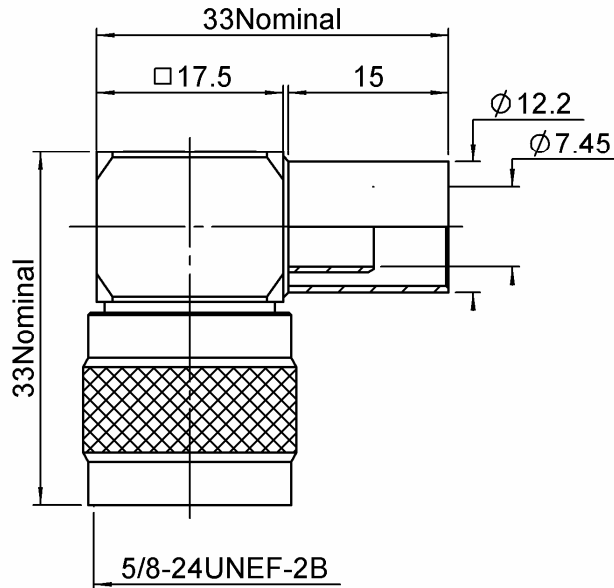

All dimensions are in mm.

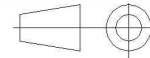

COMPONENTS	MATERIALS	PLATING (µm)
BODY	BRASS	BBR
CENTER CONTACT	BRASS	GOLD
OUTER CONTACT	BRASS	BBR
INSULATOR	PTFE	
GASKET	SILICONE RUBBER	
OTHERS PARTS	BRASS	BBR
-	-	-
-	-	-

Issue : 0910 A

In the effort to improve our products, we reserve the right to make changes judged to be necessary.



**RIGHT ANGLE PLUG CRIMP TYPE**

**R161A.186.000**

**FOR CABLE 11/50D**

Series : **ECO N**

**PACKAGING**

Standard	Unit	Other
<b>50</b>	<b>'W' option</b>	<b>Contact us</b>

**SPECIFICATION**

**ELECTRICAL CHARACTERISTICS**

Impedance	<b>50</b>	$\Omega$
Frequency	<b>0-6</b>	GHz
VSWR	<b>1.35 + 0.0000</b>	x F(GHz) Maxi
Insertion loss	<b>0.1</b>	$\sqrt{F}$ (GHz) dB Maxi
RF leakage	- ( <b>NA</b> )	- F(GHz)) dB Maxi
Voltage rating	<b>1400</b>	Veff Maxi
Dielectric withstanding voltage	<b>2500</b>	Veff mini
Insulation resistance	<b>5000</b>	M $\Omega$ mini

**CABLE ASSEMBLY**

Stripping	a	b	c	d	e	f
mm	3.50	10.0	21.0	0.00	17.5	0.00

Assembly instruction : **Crimp 05**

Recommended cable(s)  
RG 214  
KX 13

Characteristics indicated on this data sheet are those that can be achieved with the highest performance cable. Intrinsic limitations of the cable may diminish the performance of the assembly

Cable retention

- pull off **400** N mini  
- torque **NA** N.cm

**MECHANICAL CHARACTERISTICS**

Center contact retention		
Axial force – Mating end	<b>27</b>	N mini
Axial force – Opposite end	<b>27</b>	N mini
Torque	<b>NA</b>	N.cm mini

**TOOLING**

Part Number	Description	Hexagon
R282.231.000	CRIMPING TOOL	10.54

Recommended torque		
Mating	<b>130</b>	N.cm
Panel nut	<b>NA</b>	N.cm
Clamp nut	<b>NA</b>	N.cm
A/F clamp nut	<b>0.0000</b>	mm

**OTHER CHARACTERISTICS**

**ENVIRONMENTAL**

Operating temperature	<b>-40/+85</b>	$^{\circ}$ C
Hermetic seal	<b>NA</b>	Atm.cm3/s
Panel leakage	<b>NA</b>	

Issue : **0910 A**

In the effort to improve our products, we reserve the right to make changes judged to be necessary.

