

ENG. NO.
SD-70021-0*06
0*23

EDP NO.
—#—

:MM DIMENSIONS IN METRIC DO NOT SCALE DRAWING

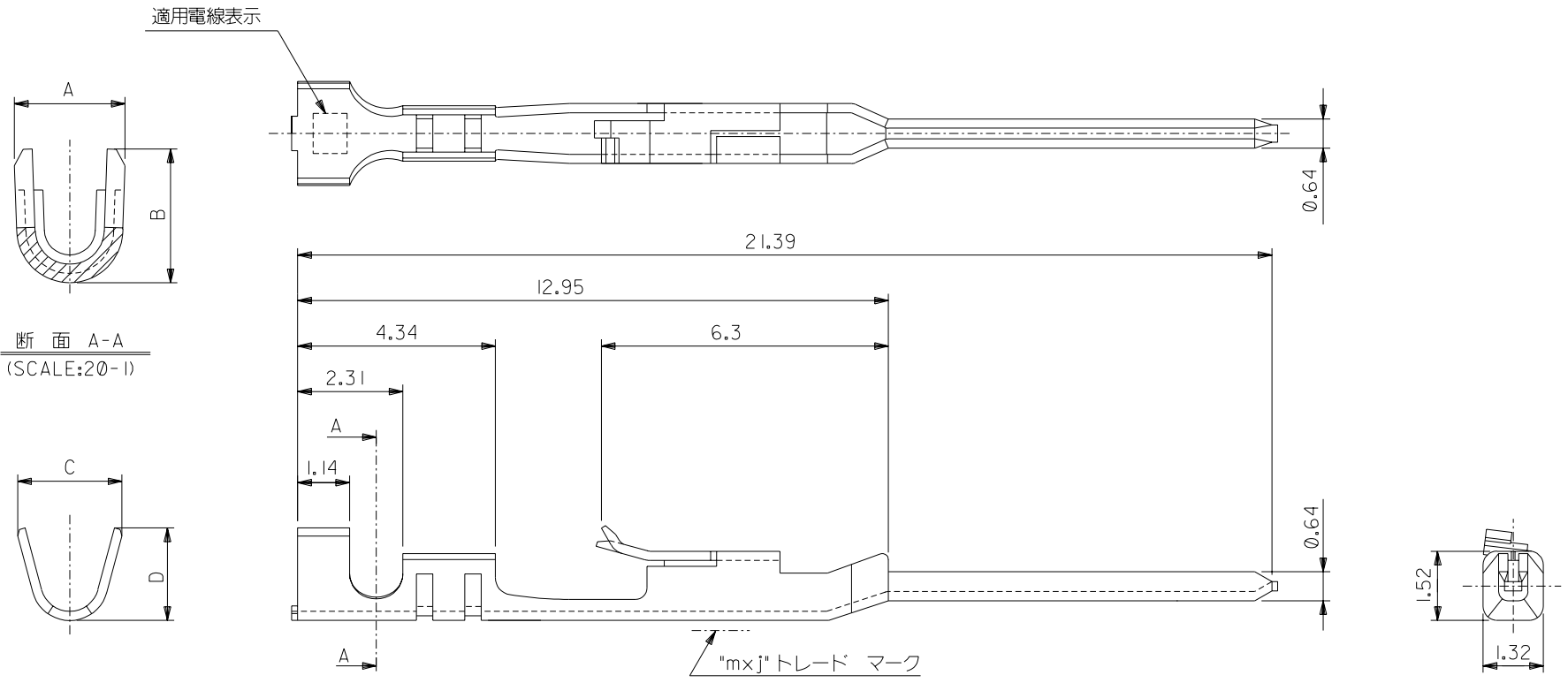

注記:

- 適合ハウジング: 70066-****, 70107-****
- メッキ仕様:
 - 接点部 : 金メッキ, 0.38 μmMIN.
 - 圧着部 : 錫メッキ, 1.91 μmMIN.
 - 下地メッキ: ニッケルメッキ, 1.27 μmMIN.

1.91	2.1	1.47	1.22	A	φ 1.6 MAX.	AWG#24-#30	連鎖状	70021-0006
1.91	2.1	1.65	1.84	C		AWG#22-#24	バラ状	70021-0223
D	C	B	A	適用電線表示	被覆外径	適用電線範囲	端子形状	MATERIAL No.

材料 MATERIAL	磷青銅 t 0.203	molex MOLEX-JAPAN CO.,LTD. 日本モレックス株式会社
仕上げ FINISH	注記参照	
適用電線範囲 WIRE RANGE	表参照	EDP. NO. —#—
被覆外径 INS. RANGE	表参照	ENG. NO. SD-70021-0*06 0*23

角度 ANGLE	±3°	B 変更 (J2004-4519)	1/11/94	M.S.	04/05/31
30 以上 OVER	+0.3	A 変更 (JD60398)	1/11/95	M.S.	95/12/07
10 以上 OVER	+0.25	0 新規作成 (T00110)	1/11/99	M.S.	99/4/6
10 未満 UNDER	+0.2	記号 変更内容 REVISION RECORD	DR. CHK.	日付 DATE	
一般公差 GENERAL TOLERANCES	REVISE ONLY ON CAD SYSTEM				

DRAWN BY	CHK'D BY
A. Mitake	M. Kuro
APP'D BY	尺度
S. Yamada	SCALE 10-1

TITLE 名称	SL MALE CRIMP TERMINAL -LEAD FREE-
REV	B

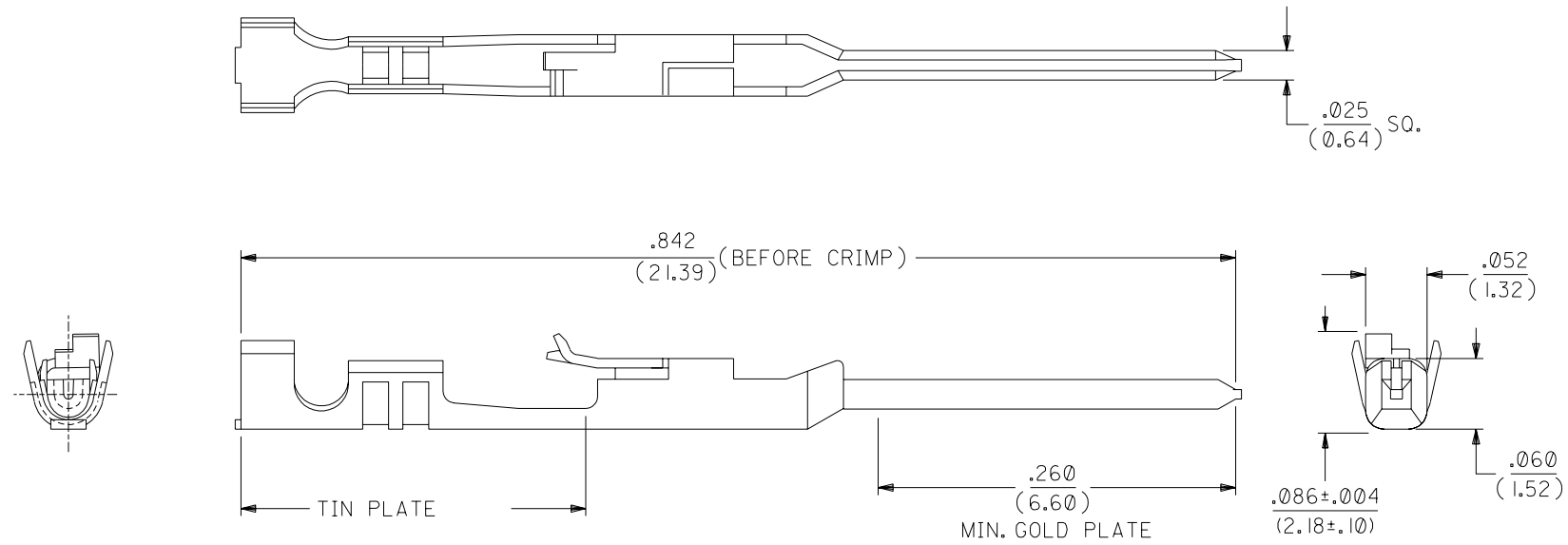

NOTES:

1. TERMINAL FOR USE WITH HOUSING PART NO. 70066-**** & 70107-****.
2. MATERIAL: .008/(0.20) THK. PHOSPHOR BRONZE.
3. TERMINAL TO BE USED WITH 24-30 AWG STRANDED WIRE WITH .060 DIA. MAX. INSULATION.
4. REFER TO MOLEX OPERATIONAL AND SERVICE MANUAL FOR DETAILS.
5. REFER TO PRODUCT SPECIFICATION NO. PS-70021.
6. PARTS SUPPLIED IN REEL FORM.

PLATING:

15 GOLD - .000015 MIN. GOLD PLATE IN SELECT AREA,
 .000075 MIN. TIN PLATE IN SELECT AREA,
 OVER .000050 MIN. NICKEL PLATE OVERALL.

*THE PRIMARY SHIPPING CARTON WILL BE LABELED "COMPLIANT TO
 RoHS DIRECTIVE 2002/95/EC AND ELV ANNEX II OF DIRECTIVE 2000/53/EC".
 CARTONS WITHOUT THIS LABEL MAY CONTAIN PRODUCT WITH LEAD.

G	LEAD FREE LUCP2004-1769 RWHITE 04/03/12
FI	REVISED ECR #U80270 MCGRATH 97/07/31
F	REVISED PLTG. SPEC. PER ECR # U31149 08/19/93 REED
E	REVISED PER ECR# U82200 11-07-88 MJM/MGB
D	REDRAWN ON CAD PER E.C.R. #9509 11/10/86 WJF/MJM

MFG.	SH.	REV.	LTR.	REVISIONS
------	-----	------	------	-----------

DIMENSIONS SHOWN (METRIC) INCH		▽ = 0 ▼ = 0		REVISE ONLY ON CAD SYSTEM	
UNLESS OTHERWISE SPECIFIED TOLERANCES: ANGULAR ± 1/2°					
		INCH		METRIC	
3 PLACE	± .010	---			
2 PLACE	± .015	± 0.25			
1 PLACE	---	± 0.35			
DRAFT WHERE APPLICABLE MUST REMAIN WITHIN DIMENSIONS					
DRWG. BY	WJF	CHK'D. BY	MJM		
APP'D. BY	WAZ	SCALE	10:1		
FILE NAME		SHEET NO.		DATE	
S70021X5 DGN		1		10/30/86	
PART NO.		DRWG. NO.			
16-02-0077		SD-70021-0006			
THIS DRAWING CONTAINS INFORMATION THAT IS PROPRIETARY TO MOLEX INC. AND SHOULD NOT BE USED WITHOUT WRITTEN PERMISSION.					
				DIV.	SIZE
				DA	B