

13 12 11 10 9 8 7 6 5 4 3 2 1

NOTES:

- 1) MATERIAL:
 BLANK: NYLON 6/6, 94V-2, COLOR: NATURAL.
 210 : NYLON 6/6, 94V-0, COLOR: NATURAL.
 210-BL : NYLON 6/6, 94V-0, COLOR: BLACK.
- 2) PART MATES WITH MOLEX PLUG #5559-*, VERTICAL HEADER #5566-*, AND RIGHT-ANGLE HEADER #5569-*.
- 3) PART IS DESIGNED IN METRIC.
- 4) PART IS FOR USE WITH MOLEX FEMALE TERMINAL #5556-*.
- 5) PRODUCT SPECIFICATION: PS-5556-001

CKT SIZE	DIM A
2	.378 (9.60)
4	.709 (18.00)
5	.874 (22.20)
6	1.039 (26.40)
7	1.205 (30.60)
8	1.370 (34.80)
9	1.535 (39.00)
10	1.701 (43.20)
11	1.866 (47.40)
12	2.031 (51.60)

PART NUMBER	ENG. NUMBER	CKT. SIZE	MATERIAL (SEE NOTE 1.)
39-01-4020	5557-02R2	2	94V-2
39-01-4021	5557-02R2-210	2	94V-0
39-01-4040	5557-04R2	4	94V-2
39-01-4041	5557-04R2-210	4	94V-0
39-01-4050	5557-05R2	5	94V-2
39-01-4051	5557-05R2-210	5	94V-0
50-30-4447	5557-05R2-210-BL	5	94V-0
39-01-4060	5557-06R2	6	94V-2
39-01-4061	5557-06R2-210	6	94V-0
39-01-4070	5557-07R2	7	94V-2
39-01-4071	5557-07R2-210	7	94V-0
39-01-4080	5557-08R2	8	94V-2
39-01-4081	5557-08R2-210	8	94V-0
39-01-4090	5557-09R2	9	94V-2
39-01-4091	5557-09R2-210	9	94V-0
39-01-4100	5557-10R2	10	94V-2
39-01-4101	5557-10R2-210	10	94V-0
39-01-4110	5557-11R2	11	94V-2
39-01-4111	5557-11R2-210	11	94V-0
39-01-4120	5557-12R2	12	94V-2
39-01-4121	5557-12R2-210	12	94V-0

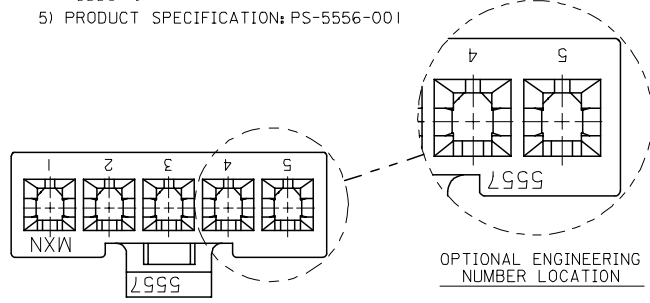

LEGEND:

CKT. SIZE _____ 5557-*** R2-***-***
 (02, 04-12)

RECEPTACLE
 (SINGLE ROW)

MATERIAL OPTION:
 (SEE NOTE 1)

COLOR:
 BLANK = NATURAL
 BL = BLACK

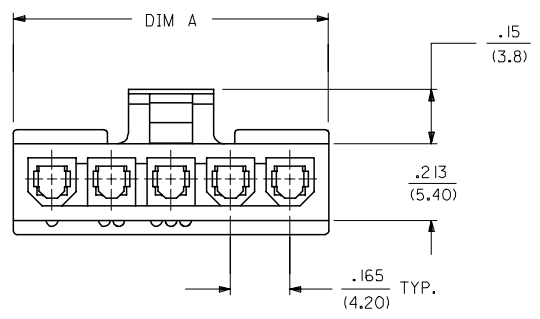
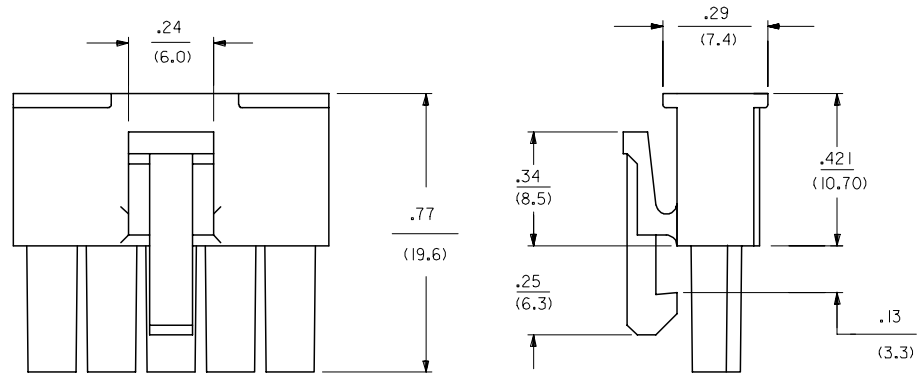
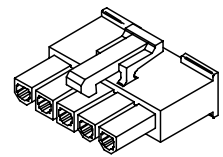

ADD'D 5557-05R2-210-BL EC NO: UICP2006-0276 DRAWN/DONE 2005/08/09 CHK'D: GPOLGAR 2005/08/09 APPR: JCOMERCJ 2005/08/11 REV DESCRIPTION	QUALITY SYMBOLS	GENERAL TOLERANCES (UNLESS SPECIFIED)	DIMENSION STYLE	SCALE	DESIGN UNITS	THIRD ANGLE PROJECTION															
	$\nabla=0$ $\nabla=0$	<table border="1"> <thead> <tr> <th></th> <th>mm</th> <th>INCH</th> </tr> </thead> <tbody> <tr><td>4 PLACES</td><td>± .010</td><td>± .0004</td></tr> <tr><td>3 PLACES</td><td>± .015</td><td>± .0006</td></tr> <tr><td>2 PLACES</td><td>± .025</td><td>± .0010</td></tr> <tr><td>1 PLACE</td><td>± .038</td><td>± .0015</td></tr> </tbody> </table>		mm	INCH	4 PLACES	± .010	± .0004	3 PLACES	± .015	± .0006	2 PLACES	± .025	± .0010	1 PLACE	± .038	± .0015	IN/MM	4:1	INCH	
		mm	INCH																		
	4 PLACES	± .010	± .0004																		
3 PLACES	± .015	± .0006																			
2 PLACES	± .025	± .0010																			
1 PLACE	± .038	± .0015																			
			<table border="1"> <tr><td>DRAWN BY</td><td>DATE</td></tr> <tr><td>KSS</td><td>2/15/89</td></tr> <tr><td>CHECKED BY</td><td>DATE</td></tr> <tr><td>RJF</td><td>2/15/89</td></tr> <tr><td>APPROVED BY</td><td>DATE</td></tr> <tr><td>RAS</td><td>2/15/89</td></tr> </table>	DRAWN BY	DATE	KSS	2/15/89	CHECKED BY	DATE	RJF	2/15/89	APPROVED BY	DATE	RAS	2/15/89	MINI-FIT JR. RECEPTACLE (SINGLE ROW)					
DRAWN BY	DATE																				
KSS	2/15/89																				
CHECKED BY	DATE																				
RJF	2/15/89																				
APPROVED BY	DATE																				
RAS	2/15/89																				
		DRAFT WHERE APPLICABLE MUST REMAIN WITHIN DIMENSIONS	MATERIAL NO. SEE CHART	DOCUMENT NO. SD-5557-NR2*	MOLEX INCORPORATED																

MATERIAL NO. SEE CHART		DOCUMENT NO. SD-5557-NR2*		MOLEX INCORPORATED	
SHEET NO. 1 OF 1			THIS DRAWING CONTAINS INFORMATION THAT IS PROPRIETARY TO MOLEX INCORPORATED AND SHOULD NOT BE USED WITHOUT WRITTEN PERMISSION		

12 11 10 9 8 7 6 5 4 3 2 1