

AMVECO... Making a World of Difference in Toroidal Transformers.

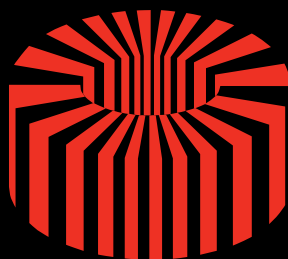

AMVECO
TOROIDAL POWER PRODUCTS



AMVECO
TOROIDAL POWER PRODUCTS

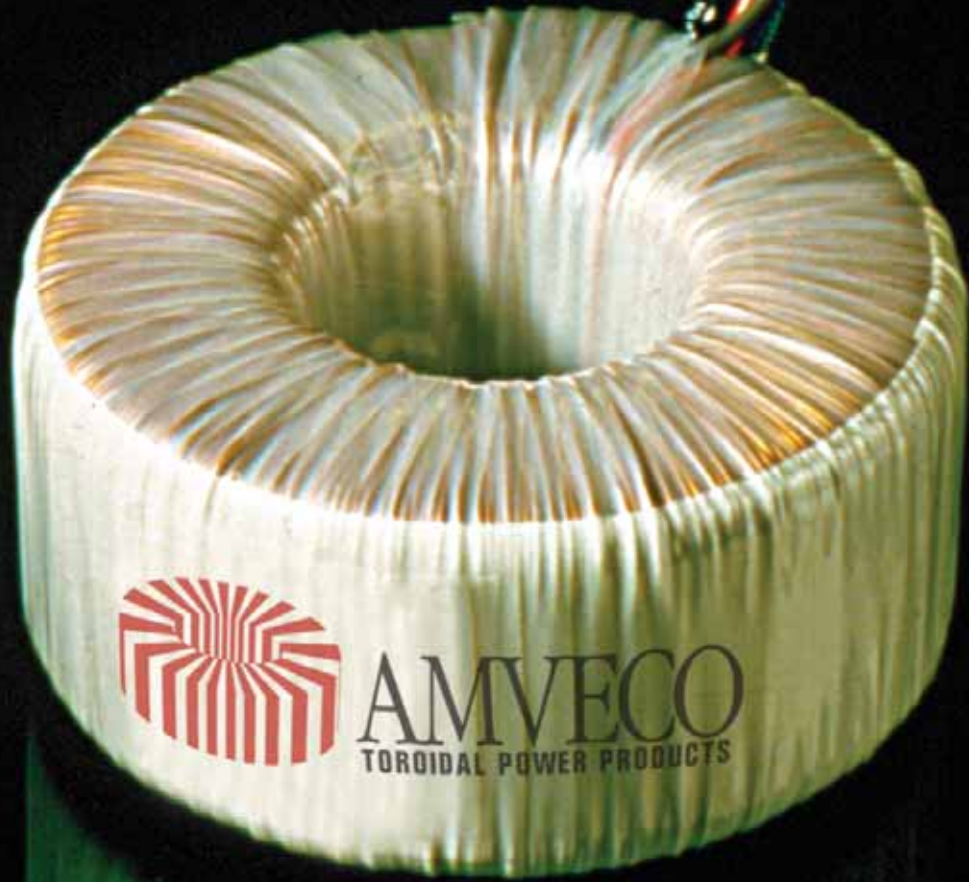

On this page you can learn about the benefits of using AMVECO toroidal transformers. Of special importance are the following points:

- *AMVECO is an ISO 9001 registered company*
- *AMVECO's transformers use only flame-retardant material (UL 94-V2)*
- *AMVECO offers lifetime warranty for its products*
- *AMVECO's transformers are recognized to several UL standards and certified by CSA as well as TUV for medical applications.*

High Performance Products For Your High Performance Applications.



SMALL SIZE

Most toroids are smaller than their E-I transformer counterparts. Electrical and mechanical designers appreciate a toroid's compact dimensions. They are particularly well suited where low height is a consideration.



LOW STRAY MAGNETIC FIELD

Toroids have no airgaps: primaries and secondaries are wound uniformly around the entire core. As a result, toroids emit very low radiated magnetic fields. This makes the toroid ideal for applications involving high sensitivity circuitry.



LOW MECHANICAL HUM

The core of a toroid is formed from a single strip of grain-oriented electrical grade silicon steel tightly wound in the form of a clock spring with the ends spot-welded in place. The copper wire is wound over polyester film, forming a silent, stable unit without the use of environmentally unfriendly glues or varnishes.



FLEXIBLE DIMENSIONS

Compounding the benefits of low weight and small size is the flexibility to vary dimensions. Because AMVECO is not tied down to core caps or lamination sizes, the height and diameter of our toroids may be economically varied to accommodate equipment design requirements.



LOW WEIGHT

Because they are more efficient, toroids can be up to 50% lighter, (depending on power rating), than conventional laminated transformers. Low weight simplifies end product design by reducing mounting hardware and supporting enclosure requirements.



LOW NO-LOAD LOSSES

Compared to conventional E-I transformers, toroids exhibit extremely low no-load losses. In applications where a circuit is in a "stand-by" mode for long periods, the potential cost reduction for power can be significant, sometimes 80-90%.



HIGH EFFICIENCY

Due to its unique construction, toroids are typically between 15 and 30% more efficient than the conventional type. As a rule; the larger the transformer, the more efficient it becomes.



LOW OPERATING TEMPERATURE

Since most of the losses in a toroid are in the copperwire, the toroid cools off quicker than the conventional E-I type with more iron. At half the load, the toroid's temperature rise is only about 30% of what it is at full load.



EASY TO MOUNT

A single-center screw easily and quickly mounts the toroid, avoiding costly mechanical design and practical problems associated with conventional E-I-laminated transformers... and three screws are eliminated at assembly!



Winding Area

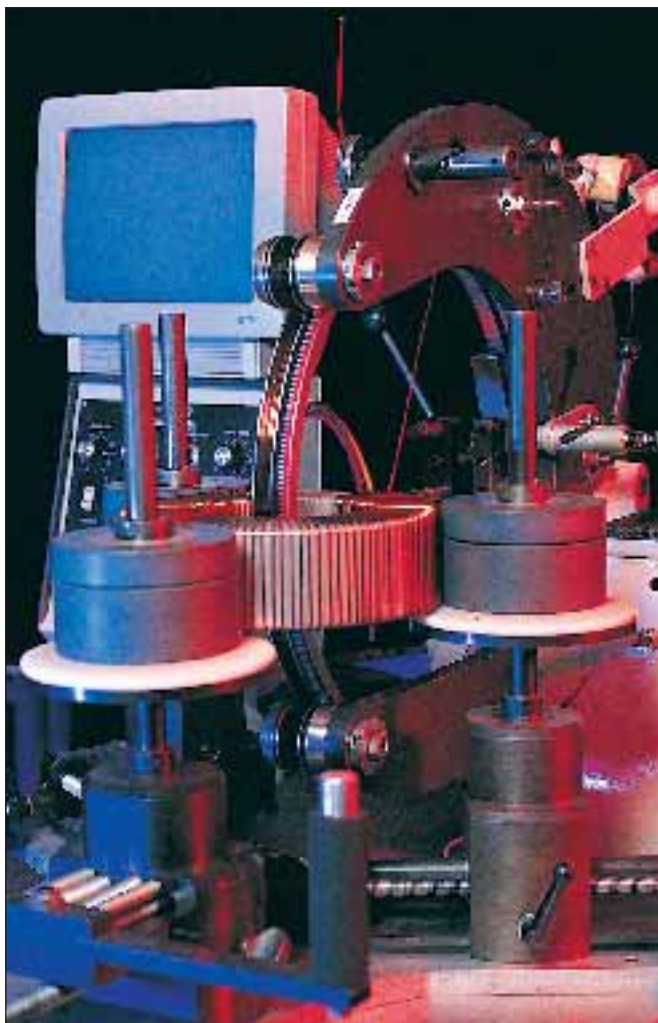

Copper windings are uniformly wound over entire core, providing better coupling and minimum flux leakage

Features, Advantages and Benefits of Toroidal Power Transformers _____	1
Serving A Broad Range Of Industries _____	3
Value Added Assembly Service _____	3
Engineering Support _____	3
Documented Reliability (ISO 9001 And Safety Standards) _____	4
AMVECO Construction Detail _____	5
Comparison Data _____	6
Reference Guide For Size And Losses _____	7
Toroidal Mounting Methods _____	8
Standard Design Transformers For 117V/60Hz Applications _____	9
Standard Design Transformers For 2x117V/50-60Hz Applications _____	10
Standard Design Medical Grade High Isolation Transformers _____	11
Custom Designed Auto-Transformers And Three-Phase Transformers _____	12
Quality To The Core _____	13
Low Profile PC Mount Transformers _____	14
Low Profile Miniature Transformers _____	15
AMVECO Standard Series Inductors _____	16
Considerations When Using Toroidal Power Transformers _____	17
Customer Specification Sheet _____	18

THE SUPERIOR/COST-EFFECTIVE TOROID

AMVECO's state-of-the-art manufacturing processes have made the use of toroids cost-effective across a broad spectrum of applications.

Toroids are routinely replacing laminated frame types in the most demanding industry applications, including: medical, telecommunications, instrumentation, test equipment, lighting and signs, process control, office and computer peripherals, audio and broadcast, as well as many others.

HIGHER LEVEL ASSEMBLY

AMVECO's higher level assembly services deliver products one step closer to production. This approach can save you time and money while AMVECO's in-house tooling and testing capabilities ensure prompt delivery of high quality products ready for your final assembly.

COMPLIMENTARY PRODUCTS

AMVECO also designs and produces standard and custom inductors, current transformers and auto transformers. All custom components are designed and manufactured to meet customer specifications and are also subjected to the same demanding manufacturing standards used in the production of our toroidal transformers. These complimentary products have been developed, and will continue to be developed, in response to your needs.



Higher Level Assembly



Compliance Testing and Marking

WE ARE HERE TO SERVE YOU

Our engineers want to be part of your power supply design group. We'll show you how you can optimize your product's appearance and performance and reduce total cost.

Since most of our products are custom designed, our work begins with a customer inquiry. Together with a customer's engineers, we determine the AC line, AC or DC load requirements and other user-specific conditions. With state-of-the-art proprietary CAD programs, our engineers quickly generate preliminary designs. Often in a matter of hours, if needed.



Powering Lasers



Toroids for Medical Isolation

Our tested and proven in-house software programs enable us to simulate optimum performance characteristics from your data. All of our design proposals are accompanied by a price quotation. You can then order a prototype for your evaluation, or select from our extensive inventory of standard toroids. You incur no expense until you place an order.

AMVECO can respond quickly and effectively to meet your needs because we have experienced people to assist you at every step, from the factory to the field. Expert application and product engineers can work with you from initial development through final delivery. Our knowledgeable customer service personnel utilize fully computerized processing systems for prompt, reliable service. Our representative organizations are strategically located to meet your needs nationwide.

SAFETY STANDARDS

AMVECO proudly holds Certificates from both North American and International Safety Standard Testing Laboratories in addition to having its factory certified to ISO 9001.

Family Approvals (recognitions) which eliminate the need to send new designs for destructive testing.

- UL 506 General Purpose Transformers (File # E 122978)
- UL 6500, Audio, Radio and Television Products (File # E 217481)
- UL 1950 Information Technology Equipment, Electrical Business Equipment (File # E 138299)
- UL 544/UL 2601 Medical and Dental Equipment (File # E 138299)
- UL 1446, Class B, Class F and Class H Insulation Systems (File # E 123069)
- CSA 22.2 No. 66-1988 Specialty Transformers (File # LR 86989)
- CSA 22.2 No. 601.1 M90 Medical Standard for Canada (File # E 138299)
- IEC 601.1 (Medical Standard for International Installations)
- EN 60601 Medical Standard for European Installations
- EN 60742/EN 61558 European Safety Standard for General Purpose Transformers

AMVECO maintains an active policy to invest in family approvals of different domestic and international safety standards in direct response to market needs and to better serve its customer base.

EXPERT CERTIFICATION GUIDANCE

AMVECO can also provide test data and construction documentation required by regulatory agencies. The major agencies throughout the world have already tested our standard lines and certification for most toroid applications is on hand, including UL, CSA, TUV and CE marking is an available option.

ISO 9001 CERTIFIED QUALITY SYSTEM

With ISO 9001 Certification as a cornerstone, since 1992, AMVECO's quality policy represents a never-ending process that involves the commitment of every employee. This commitment is proven every day, at every step in the manufacturing process through delivery of our products to you.

Convenient One-Bolt Mounting



Harnessing with Connectors



Toroids are Used for Lighting and Signs



UNMATCHED QUALITY/UNPARALLELED SERVICE

Power system design engineers have come to recognize AMVECO as the leading manufacturer of custom toroidal power transformers and inductors.

Over the years since 1982, we have built a reputation for excellence by focusing on design engineering state-of-the-art production capabilities and customer support services. Our quality management system has been ISO 9001 certified since 1992.

When you select AMVECO for your power transformer needs you acquire a team of experienced professionals that offer assistance from design to delivery and beyond.

One simple fact verifies our quality claims: our customers stay with us year after year and continue to trust us with their new product needs.

In addition to Class A insulation system, Amveco offers Class B (130 °C), Class E (120 °C), Class F (155 °C) and Class H (180 °C).

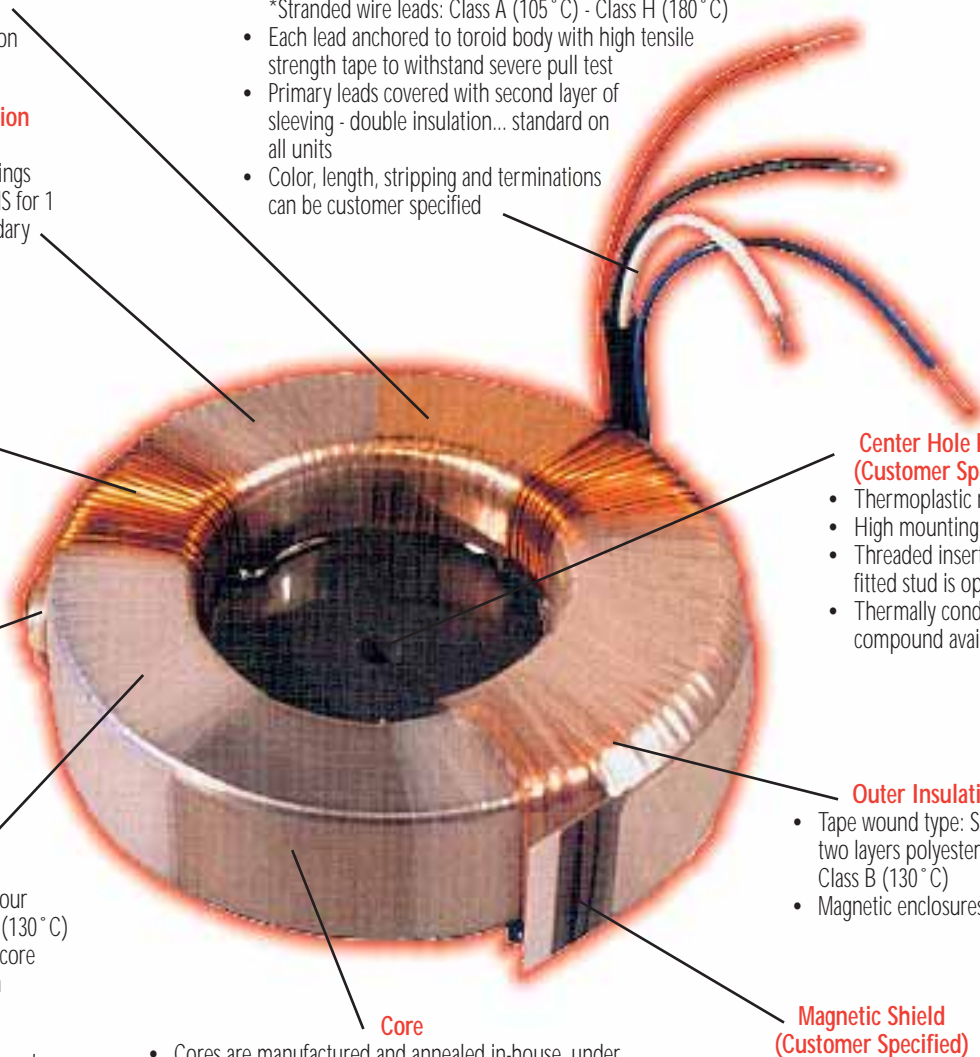

Electrostatic Shield (Customer Specified)

- Reduces capacitive coupling between primary and secondary windings
- Copper foil (2 mil) laminated between polyester film and tape
- Tightly wound over primary insulation

Wire Leads

- Choice of two types of leads connected to windings:
 - *Self leads: The magnet wire is extended through sleeving for connection to circuit. Standard: Class A (105 °C)
 - *Stranded wire leads: Class A (105 °C) - Class H (180 °C)
- Each lead anchored to toroid body with high tensile strength tape to withstand severe pull test
- Primary leads covered with second layer of sleeving - double insulation... standard on all units
- Color, length, stripping and terminations can be customer specified

Primary to Secondary Insulation

- Polyester film-Class B (130 °C)
- Four layers minimum between windings
- Meets test requirement of 4000V RMS for 1 minute between primary and secondary

Windings

- Base coat of Polyester. Heavy topcoat of amide imide (200 °C)
- Wound uniformly over entire core
- Better heat dissipation
- Windings configured for minimum flux leakage
- Low voltage maintained between adjacent turns

Center Hole Potting (Customer Specified)

- Thermoplastic material
- High mounting precision
- Threaded insert or press fitted stud is optional
- Thermally conductive compound available

Thermal Protection (Customer Specified)

- Usually in primary circuit
- Normally closed-auto reset opens at high temperature
- One-shot fuse also available
- UL, CSA, VDE listed components

Outer Insulation

- Tape wound type: Standard two layers polyester film Class B (130 °C)
- Magnetic enclosures optional

Core Insulation

- All cores: 100% surface coverage of four layers of 2 mil polyester film Class B (130 °C)
- Protects, insulates and cushions the core from windings and reduces vibration

Magnetic Shield (Customer Specified)

- Multiple layers of grain oriented silicon steel tightly wound around the toroid's circumference
- Fixed in place by outer insulation

Core

- Cores are manufactured and annealed in-house, under controlled conditions
- Continuous tightly wound grain oriented silicon steel... no airgaps, no mechanical noise
- Lathed radial corners... compact design, most efficient use of materials
- No core caps necessary

AMVECO's unique method to protect the wire from the sharp corners of the core during the winding operation permits unlimited choice of core size to best meet the customer's available space. Other methods include use of plastic end caps or dipping the core in epoxy. Amveco can offer these methods too, if preferred by the customer.

COMPARISON DATA

Weight Comparison: Toroid vs. E-I Transformer

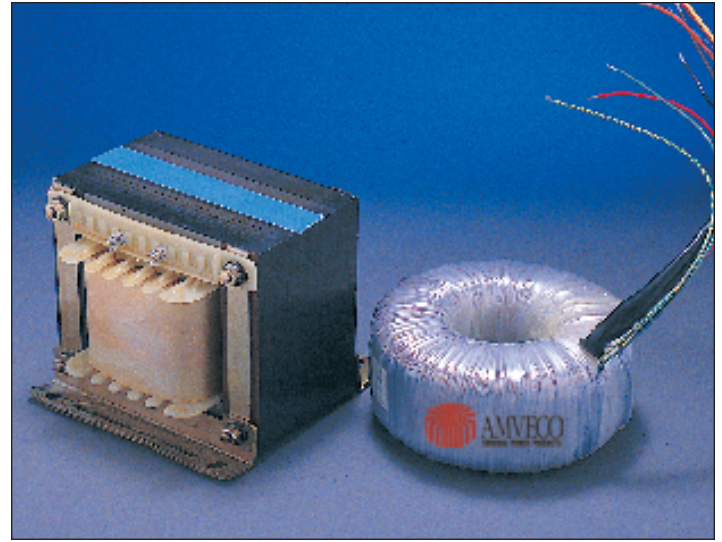
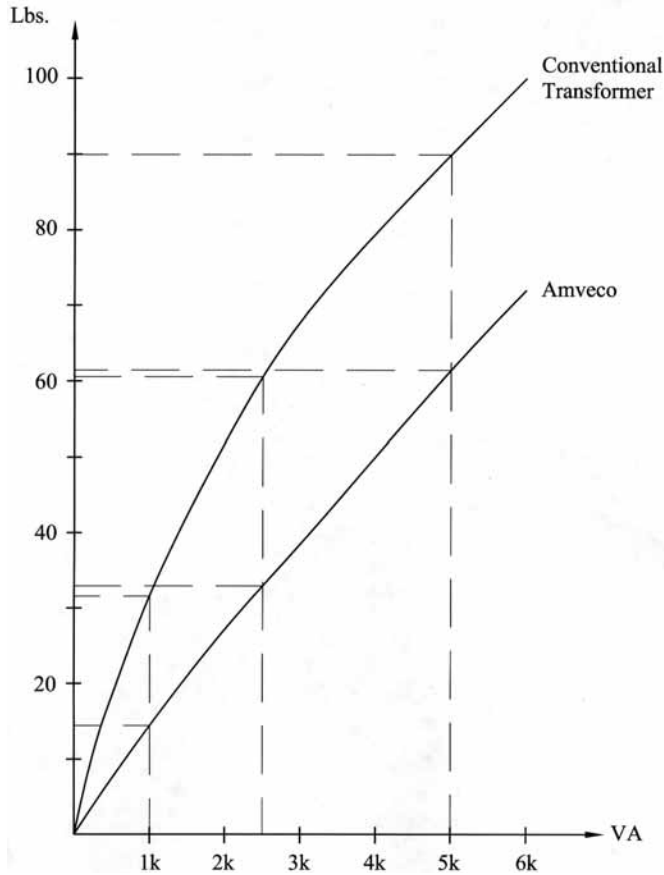

Overall Comparison of 250 VA E-I Core Isolation Transformer vs. 250 VA E/I-Core AMVECO Isolation Transformer

Feature	E-I Core Transformer	AMVECO
Height	4.7" (119 mm)	2.2" (56 mm)
Width	3.9" (99 mm)	4.5" (114 mm)
Depth	4.3" (109 mm)	4.5" (114 mm)
Volume	78.8 sq. in. (508.4 cm ²)	35.0 sq. in. (225.8 cm ²)
Dimensional Adaptability	Limited by available dies	All dimensions can be adjusted
Weight	10 lb. (4.5 kg)	5 lb. (2.3 kg)
Mounting Requirements	Four corner bolts	Single bolt through center
No-load Loss	10.0 W	1.5 W
Continuity of Magnetic Path	50% of grain perpendicular	100% parallel grain orientation
Air Gaps	Approximately 180 (60 laminations x 3)	None
Magnetic Properties of Core	Affected by clamping welding, banding, etc.	Optimized prior to winding and remain stable
Coupling Factor	Limited by bobbin width and layers of windings	Maximized by even winding distribution & close proximity to core
Long-term Reliability	Thermal cycling and vibration steadily degrade performance	Lifetime Warranty



Completing a "King-size" Toroid

REFERENCE GUIDE FOR PHYSICAL SIZE AND LOSS DATA OF CUSTOM DESIGNED TOROIDAL TRANSFORMERS UP TO 12 KVA

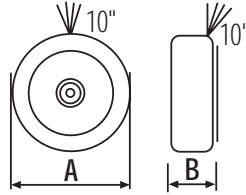

DISK MOUNTING

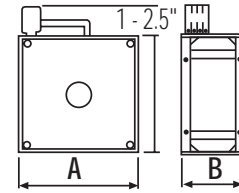

FLANGE MOUNTING

Nominal Power (VA)		Copper Losses ^(*) (W)	Core Losses (W)	Dimensions			Dimensions		
				A inch (mm)	B inch (mm)	Weight lb (kg)	A inch (mm)	B inch (mm)	Weight lb (kg)
50-60 Hz	60Hz								
15	18	3.0	0.20	2.5 (64)	1.3 (33)	0.7 (0.3)			
30	36	5.8	0.25	3.0 (76)	1.5 (38)	1.1 (0.5)	N/A	N/A	N/A
50	60	8.6	0.45	3.2 (81)	1.4 (36)	1.6 (0.7)			
80	95	12.0	0.60	3.9 (99)	1.5 (38)	2.2 (1.0)			
120	145	16.0	0.90	3.9 (99)	1.9 (48)	3.0 (1.4)			
160	190	19.0	1.20	4.5 (114)	1.7 (43)	3.8 (1.7)	N/A	N/A	N/A
225	270	20.0	1.40	4.5 (114)	2.0 (51)	4.9 (2.2)			
300	360	22.0	1.70	4.6 (117)	2.6 (66)	5.7 (2.6)			
400	480	27.0	2.00	5.4 (137)	2.0 (51)	6.5 (3.0)	5.7 (145)	3.3 (84)	8.1 (3.7)
500	600	31.0	2.40	5.4 (137)	2.4 (61)	8.0 (3.6)	5.7 (145)	3.7 (94)	9.6 (4.4)
625	750	36.0	3.10	5.5 (140)	3.2 (81)	9.5 (4.3)	5.7 (145)	4.2 (107)	11.1 (5.0)
800	960	45.0	3.80	6.4 (163)	2.7 (69)	12.3 (5.6)	6.9 (175)	3.9 (99)	14.6 (6.6)
990	1200	45.0	4.70	6.4 (163)	3.0 (76)	16.0 (7.3)	6.9 (175)	4.3 (109)	18.3 (8.3)
1100	1320	45.0	6.50	6.4 (163)	3.3 (84)	17.0 (7.7)	6.9 (175)	4.6 (117)	19.3 (8.8)
1300	1560	60.0	5.70	8.0 (203)	2.6 (66)	20.0 (9.1)	8.3 (211)	3.9 (99)	23.0 (10.4)
1600	1920	62.0	7.10	8.0 (203)	3.0 (76)	23.0 (10.4)	8.3 (211)	4.3 (109)	26.0 (11.8)
1900	2280	65.0	8.50	8.0 (203)	3.4 (86)	26.0 (11.8)	8.3 (211)	4.7 (119)	29.0 (13.2)
2200	2640	73.0	8.10	8.9 (226)	3.3 (84)	29.0 (13.2)	9.3 (236)	5.1 (130)	33.5 (15.2)
2500	3000	79.0	9.70	8.9 (226)	3.5 (89)	33.0 (15.0)	9.3 (236)	5.3 (135)	37.5 (17.0)
2800	3360	89.0	11.00	9.8 (249)	3.1 (79)	35.0 (15.9)	10.2 (259)	4.9 (124)	41.0 (18.6)
3200	3840	91.0	11.00	9.8 (249)	3.5 (89)	42.0 (19.1)	10.2 (259)	5.3 (135)	48.0 (21.8)
3700	4440	93.0	15.00	9.8 (249)	3.9 (99)	46.0 (20.9)	10.2 (259)	5.7 (145)	52.0 (23.6)
4400	5280	112.0	17.00	11.2 (284)	4.3 (109)	53.0 (24.0)	11.6 (295)	6.1 (155)	60.0 (27.2)
5000	6000	112.0	20.00	11.2 (284)	4.7 (119)	62.0 (28.1)	11.6 (295)	6.5 (165)	69.0 (31.3)
6300	7560	130.0	27.00	12.4 (315)	4.7 (119)	76.0 (34.5)	13.8 (351)	6.5 (165)	89.0 (40.4)
8000	9600	140.0	28.00	13.4 (340)	4.7 (119)	88.0 (39.9)	13.8 (351)	6.5 (165)	101.0 (45.8)
10000	12000	140.0	39.00	13.4 (340)	5.9 (150)	120.0 (54.4)	13.8 (351)	7.7 (196)	133.0 (60.3)

The values given are typical values. () Copper losses at 25 °C ambient temperature and full load.*

Over 95% of our sales are custom designs. Because they require no elaborate production tools and are individually wound, toroidal transformers are particularly well suited to custom designs.

Take advantage of our custom design service at no obligation.

Our interactive computer design capabilities enable us to optimize design's for either AC or DC loads.

- **Quick response to requests for quotations**
- **Rapid delivery of prototypes**
- **Pre-certified by electrical safety agencies: UL and CSA**
- **Variety of mounting arrangements**
- **Lifetime Warranty**

TOROIDAL MOUNTING METHODS

DIMENSIONS OF METAL MOUNTING DISK AND INSULATING PAD				
Power Range VA	OD inch (mm)	Hole inch (mm)	Thickness inch (mm)	Recom. Hardware
20	1.7 (45)	0.18 (4.5)	0.04 (1)	#8
40-60	2.4 (60)	0.20 (5.2)	0.04 (1)	#10
100-150	2.8 (70)	0.26 (6.6)	0.04 (1)	1/4"
200-350	3.5 (90)	0.26 (6.6)	0.05 (1.3)	1/4"
425-800	4.4 (110)	0.26 (6.6)	0.06 (1.5)	1/4"
800-1200	5.2 (130)	0.33 (8.4)	0.07 (1.7)	5/16"
1200-1500	5.6 (145)	0.41 (10.3)	0.07 (1.7)	3/8"

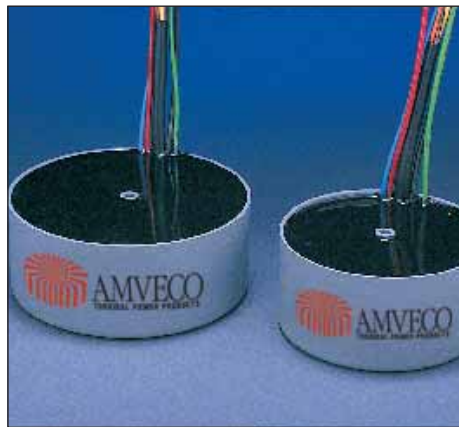
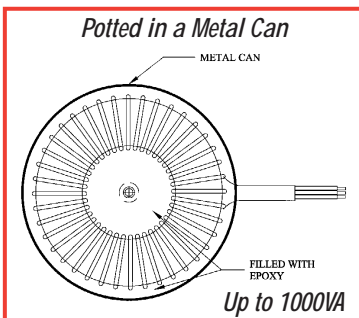
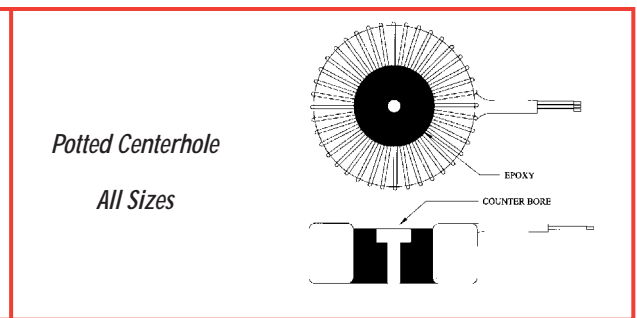
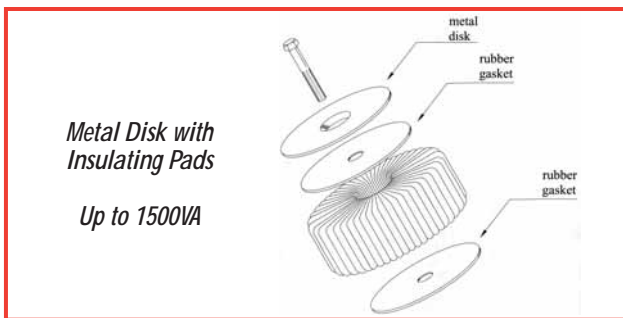

Toroids Potted in Plastic Cans

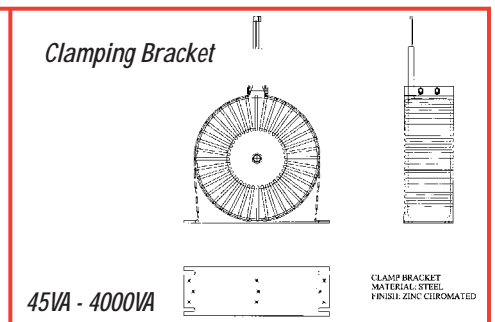
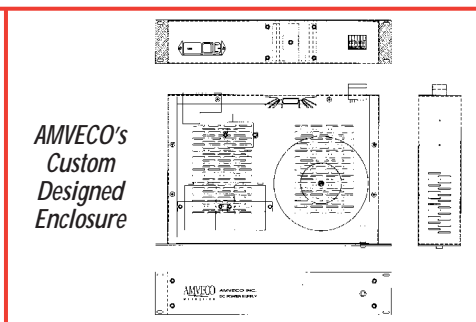
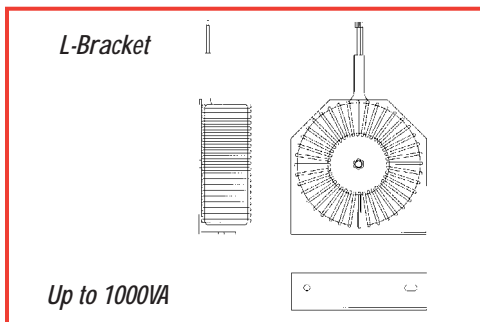
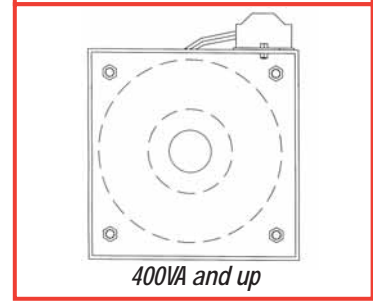
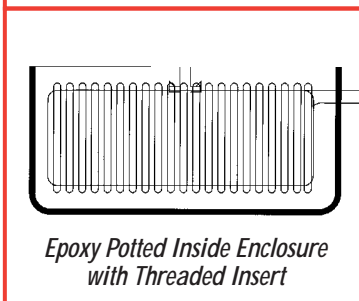
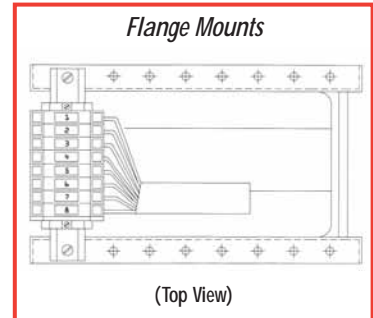

NORTH AMERICAN 120V/60HZ

- Lifetime warranty
- 120V, 60Hz
- Many popular secondary voltage options
- 18 to 1000VA ratings available
- Listed as recognized/certified components (UL and CSA)
- Class A (105 ° C)
- Disk mounting hardware included
- 10" color coded self leads

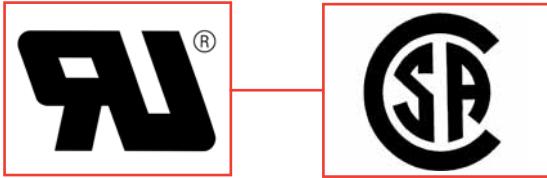

WINDING CONFIGURATIONS WITH COLOR CODES

Figure 1
Single 120V/60Hz Primary w/ Dual Secondaries

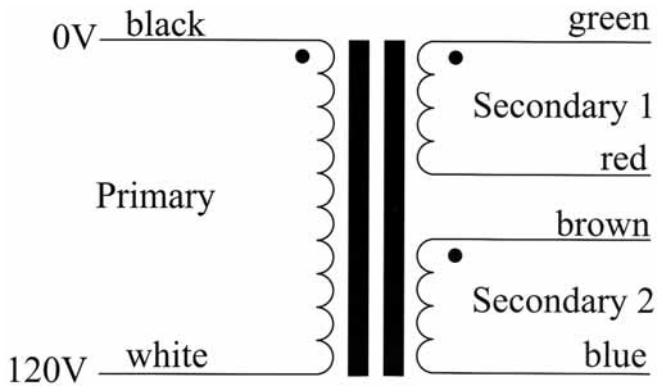
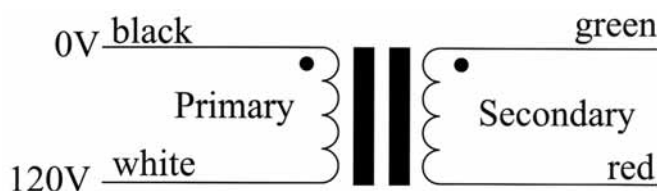

Figure 2
Single 120V/60Hz Primary w/ Single Secondary



Nominal Power VA	Secondary Voltage VAC	Secondary Current AAC	AxB ¹ in Weight lb Mounting Hardware*	AxB ¹ mm Weight kg	Part No.
18	2x9	1.0	2.5x1.3 0.7 #8	64x33 0.3	AA5018-2009 AA5018-2012 AA5018-2015 AA5018-2018
	2x12	0.7			
	2x15	0.6			
	2x18	0.5			
36	2x9	2.0	2.9x1.5 1.1 #10	74x38 0.5	AA5036-2009 AA5036-2012 AA5036-2015 AA5036-2018
	2x12	1.5			
	2x15	1.2			
	2x18	1.0			
60	2x9	3.3	3.3x1.4 1.6 #10	84x36 0.7	AA5060-2009 AA5060-2012 AA5060-2015 AA5060-2018
	2x12	2.5			
	2x15	2.0			
	2x18	1.7			
90	2x12	3.8	3.7x1.5 1.9 #10	94x38 0.9	AA5090-2012 AA5090-2015 AA5090-2018 AA5090-2022
	2x15	3.0			
	2x18	2.5			
	2x22	2.0			
115	2x12	4.8	3.9x1.5 2.2 1/4"	99x38 1.0	AA5115-2012 AA5115-2015 AA5115-2018 AA5115-2022
	2x15	3.8			
	2x18	3.2			
	2x22	2.6			
170	2x12	7.1	3.9x1.9 3.1 1/4"	99x48 1.4	AA5170-2012 AA5170-2015 AA5170-2018 AA5170-2022
	2x15	5.7			
	2x18	4.7			
	2x22	3.9			
220	220	1.0	4.5x1.8 4.0 1/4"	114x46 1.8	AA5220-1220 AA5220-2018 AA5220-2022 AA5220-2024
	2x18	6.1			
	2x22	5.0			
	2x24	4.6			
360	220	1.6	4.5x2.4 5.4 1/4"	114x61 2.5	AA5360-1220 AA5360-2024 AA5360-2030 AA5360-2033 AA5360-2038
	2x24	7.5			
	2x30	6.0			
	2x38	4.7			
450	220	2.1	5.4x2.0 6.5 1/4"	137x51 3.0	AA5450-1220 AA5450-2030 AA5450-2033 AA5450-2038
	2x30	7.5			
	2x33	6.8			
	2x38	5.9			
550	220	2.5	5.4x2.6 8.5 1/4"	137x66 3.7	AA5550-1220 AA5550-2030 AA5550-2033 AA5550-2038
	2x30	9.2			
	2x33	8.3			
	2x38	7.2			
650	120	5.4	5.4x2.8 9.5 5/16"	137x71 4.3	AA5650-1120 AA5650-2024 AA5650-2030 AA5650-2042
	2x24	13.5			
	2x30	10.8			
	2x42	7.7			
790	120	6.6	5.8x2.8 11.5 5/16"	147x71 5.2	AA5790-1120 AA5790-2024 AA5790-2030 AA5790-2042
	2x24	16.5			
	2x30	13.2			
	2x42	9.4			
1000	120	8.3	6.5x2.6 12.4 5/16"	165x66 5.6	AA5000-1120 AA5000-2024 AA5000-2030 AA5000-2042
	2x24	20.8			
	2x30	16.7			
	2x42	11.9			

The values given are typical values

**Recommended sizes*

¹See picture on page 8 (Disk Mounting)

For information about core and copper losses, see page 7

Technical data subject to change without prior notice

STANDARD DESIGN TOROIDAL TRANSFORMERS



INTERNATIONAL PRIMARIES 2X117V, 50/60HZ

- Lifetime warranty
- 2x117V, 50/60Hz primaries
- Many popular secondary voltage options
- 15 to 990VA ratings available
- Listed as recognized/certified components (UL and CSA)
- Class A (105 °C)
- Disk mounting hardware included
- 10" color coded self leads



WINDING CONFIGURATIONS WITH COLOR CODES

Dual 117V 50/60Hz Primaries w/ Dual Secondaries
Multiple primaries must be connected in series or parallel.

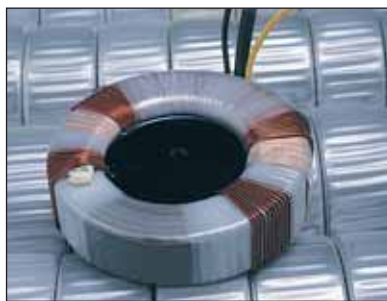
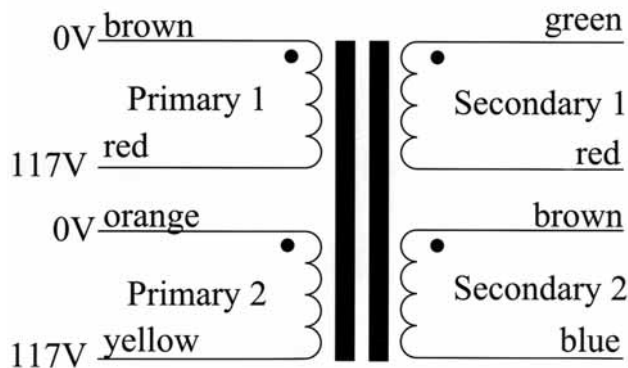

Layered Construction View

The values given are typical values
**Recommended sizes*
¹See picture on page 8 (Disk Mounting)
For information about core and copper losses, see page 7
Technical data subject to change without prior notice

Nominal Power VA	Secondary Voltage VAC	Secondary Current AAC	AxB ¹ in Weight lb Mounting Hardware*	AxB ¹ mm Weight kg	Part No.
15	2x6	1.25	2.5x1.3 0.7 #8	64x33 0.3	AA50152-006
	2x9	0.83			AA50152-009
	2x12	0.62			AA50152-012
	2x15	0.50			AA50152-015
	2x18	0.42			AA50152-018
30	2x6	2.50	3.0x1.5 1.1 #10	76x38 0.5	AA50302-006
	2x9	1.67			AA50302-009
	2x12	1.25			AA50302-012
	2x15	1.00			AA50302-015
	2x18	.88			AA50302-018
50	2x6	4.2	3.2x1.4 1.6 #10	81x36 0.7	AA50502-006
	2x9	2.8			AA50502-009
	2x12	2.1			AA50502-012
	2x15	1.7			AA50502-015
	2x18	1.4			AA50502-018
95	2x6	7.0	3.9x1.5 2.2 1/4"	99x38 1.0	AA50952-006
	2x9	4.7			AA50952-009
	2x12	3.5			AA50952-012
	2x15	2.6			AA50952-015
	2x18	2.2			AA50952-018
140	2x6	10.7	3.9x1.9 3.0 1/4"	99x48 1.4	AA51402-006
	2x9	7.1			AA51402-009
	2x12	5.3			AA51402-012
	2x15	4.0			AA51402-015
	2x18	3.2			AA51402-018
185	2x6	14.4	4.5x1.9 4.0 1/4"	114x48 1.8	AA51852-006
	2x9	9.6			AA51852-009
	2x12	7.2			AA51852-012
	2x15	5.6			AA51852-015
	2x18	4.5			AA51852-018
240	2x6	20.0	4.5x2.1 4.8 1/4"	114x53 2.2	AA52402-006
	2x9	13.3			AA52402-009
	2x12	10.0			AA52402-012
	2x15	7.5			AA52402-015
	2x18	6.0			AA52402-018
300	2x6	30.0	4.6x2.6 5.7 1/4"	117x66 2.6	AA53002-006
	2x9	20.0			AA53002-009
	2x12	15.0			AA53002-012
	2x15	11.3			AA53002-015
	2x18	9.0			AA53002-018
375	2x6	40.0	5.4x2.0 6.7 1/4"	137x51 3.0	AA53752-006
	2x9	26.7			AA53752-009
	2x12	20.0			AA53752-012
	2x15	15.0			AA53752-015
	2x18	11.7			AA53752-018
460	2x6	50.0	5.4x2.6 7.9 1/4"	137x66 3.6	AA54602-006
	2x9	33.3			AA54602-009
	2x12	25.0			AA54602-012
	2x15	18.8			AA54602-015
	2x18	14.3			AA54602-018
625	2x6	75.0	5.5x3.2 9.5 1/4"	140x81 4.3	AA56252-006
	2x9	50.0			AA56252-009
	2x12	37.5			AA56252-012
	2x15	28.1			AA56252-015
	2x18	21.3			AA56252-018
800	2x6	100.0	6.4x2.7 12.3 5/16"	163x69 5.6	AA58002-006
	2x9	66.7			AA58002-009
	2x12	50.0			AA58002-012
	2x15	37.5			AA58002-015
	2x18	28.0			AA58002-018
990	2x6	165.0	6.5x3.0 15.2 5/16"	165x76 6.9	AA59902-006
	2x9	110.0			AA59902-009
	2x12	82.5			AA59902-012
	2x15	61.9			AA59902-015
	2x18	46.4			AA59902-018

PRIMARIES FOR 100V, 120V, 220V, 240V - 50/60HZ

Medical Power & Isolation Transformers 50/60Hz

Multiple primaries must be connected in series or parallel.

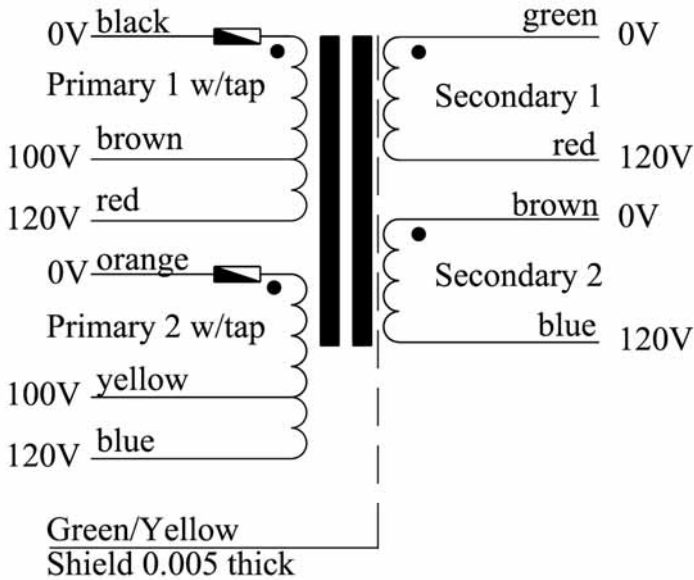

NOTE: (suffix) SS=(Single Secondary) Secondary 1 only
 (suffix) DS=(Dual Secondary) Secondary 1 & 2

- Units rated below 1000VA come with metal disk and insulating pads.
- Units rated 1000VA and larger are center potted.
- Units over 3000VA do not have thermal fuses wound in the primaries, but intended to operate external safety device.



Our part numbers - MT100 through MT5000 carry full TUV BAUARTMARK

(UL 544, UL 2601, IEC 601, CSA 22.2 NO. 601.1) RECOGNIZED MEDICAL POWER/ISOLATION TRANSFORMERS

Nominal Power VA	Secondary Current at 120 V	Secondary Current at 240 V	AxB' in Weight lb	AxB' mm Weight kg	Part No.
100	.83A		4.0x2.0 2.7	102x51 1.2	MT0100SS
100	.83A	.42A	4.0x2.0 2.7	102x51 1.2	MT0100DS
230	1.92A		4.6x2.4 5.2	117x61 2.4	MT0230SS
230	1.92A	.96A	4.6x2.4 5.2	117x61 2.4	MT0230DS
400	3.33A		5.5x2.5 8.0	140x64 3.6	MT0400SS
400	3.33A	1.67A	5.5x2.5 8.0	140x64 3.6	MT0400DS
600	5.00A		6.2x3.1 13.0	157x79 5.9	MT0600SS
600	5.00A	2.5A	6.2x3.1 13.0	157x79 5.9	MT0600DS
750	6.25A		6.6x3.0 14.0	168x79 6.4	MT0750SS
750	6.25A	3.12A	6.6x3.1 14.0	168x76 6.4	MT0750DS
1000	8.33A	4.16A	6.9x3.5 20.0	175x89 9.1	MT1000DS
1500	12.5A	6.25A	8.2x4.0 28	208x102 12.7	MT1500DS
2000	16.6A	8.33A	9.1x4.4 35	231x112 15.9	MT2000DS
2500	20.8A	10.4A	9.4x4.5 39	239x114 17.7	MT2500DS
3000	25.0A	12.5A	10.0x4.3 47	254x109 21.3	MT3000DS
3750	31.2A	15.6A	10.5x4.9 65	267x124 29.5	MT3750DS
5000	41.6A	20.8A	11.6x5.4 78	295x137 35.4	MT5000DS
6250	52.0A	26.0A	12.0x5.6 90	305x143 40.8	MT6250DS
7500	62.5A	31.2A	12.0x5.5 100	305x140 45.4	MT7500DS
8750	72.9A	36.4A	12.5x5.5 110	318x140 49.9	MT8750DS
10000	83.3A	41.6A	13.0x5.2 120	330x132 54.4	MT10000DS

The values given are typical values
 Technical data subject to change without prior notice

For mounting information, see diagrams on page 8.

AUTOTRANSFORMERS YIELD REDUCED SIZE AND COSTS

Frequently, in applications calling for simple voltage step-up or step-down, and where there is no requirement for electrical isolation, applying an autotransformer will result in significant size and weight reductions as well as cost. The power rating of an autotransformer is given by the expression:

$$P_{\text{rated}} = P_{\text{out}} \times (V_{\text{hi}} - V_{\text{low}}) / V_{\text{hi}}$$

V_{low} = voltage from lower voltage tap (input or output)

V_{hi} = voltage across higher voltage tap (output or input)

STEP UP AUTOTRANSFORMER

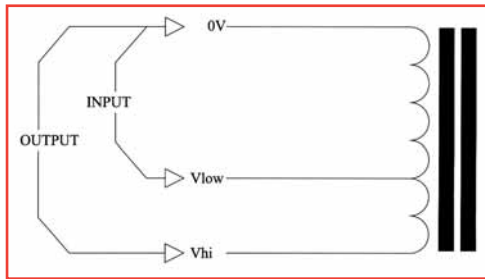

STEP DOWN AUTOTRANSFORMER

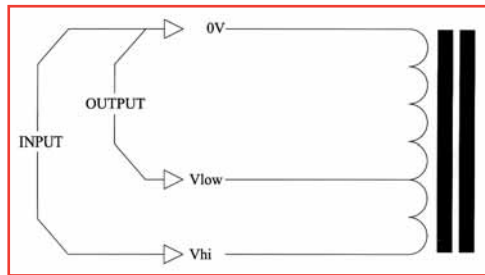

A rule of thumb to apply when considering an autotransformer is that the voltage across the entire winding should be less than or equal to two times (2x) the value of the lowest voltage tap ($V_{\text{hi}} < 2V_{\text{low}}$).

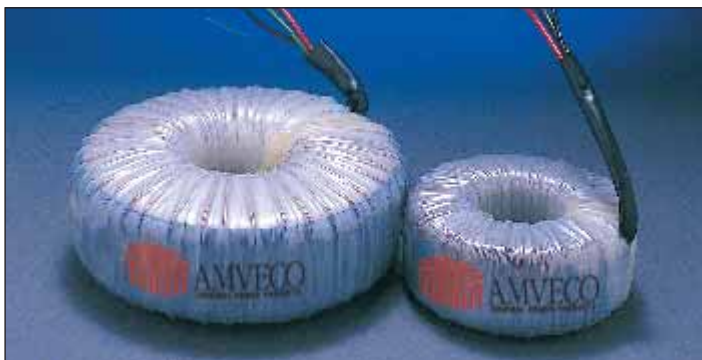

1500VA Isolation Transformer and 1500VA Autotransformer



3-Phase Toroidal Array Mounted in Flanges with Terminal Blocks

3-PHASE TRANSFORMERS

3-Phase toroidal transformers are simply three separate single phase units. When convenient, they may be mounted as individual units, adding flexibility to the design of the housing or, in many cases, stacked together side by side or stacked on top of each other. For higher powered units, the relative assembly labor is less using toroids where each phase may be handled separately (usually by one person). Compare this to E-I transformer installations where a large single unit must be moved (requiring several workers and a hoist).



AMVECO quality is ensured through superior design and state-of-the-art production facilities.



AMVECO toroids are uniquely lathed at the edges of end core to reduce size and increase performance.



Each AMVECO toroidal transformer is subjected to several tests, including 4KVAC minimum hi-pot testing between primary and secondary windings.



Amveco offers a broad line of current transformers

LOW PROFILE PC MOUNT TRANSFORMERS



Power VA	Part Number	Sec-Full Load V	Current mA	No Load Voltage	I No-Load	Reg. %	Δt °C	Eff %	Dim. LxWxH mm	Pin Layout	
										XY mm	Pin Size mm
1.6	70000	2x7	114	2x8.9	1.0 (mA)	29	10	77	39.6 x 39.6 x 18.5	35.56	1.0x0.5
	70001	2x9	89	2x11.6							
	70002	2x12	67	2x15.4							
	70003	2x15	53	2x19.3							
	70004	2x18	44	2x23.4							
70005	2x22	36	2x28.2	82 grams							
3.2	70010	2x7	229	2x10.2	1.5 (mA)	43	20	70	44.7 x 44.7 x 19.5	40.64	1.0x0.5
	70011	2x9	178	2x13.0							
	70012	2x12	133	2x17.3							
	70013	2x15	107	2x21.4							
	70014	2x18	89	2x25.7							
70015	2x22	73	2x31.3	110 grams							
5.0	70020	2x7	357	2x9.7	2.0 (mA)	40	29	68	49.7 x 49.7 x 19.5	45.72	1.0x0.5
	70021	2x9	278	2x12.4							
	70022	2x12	208	2x17.0							
	70023	2x15	167	2x21.3							
	70024	2x18	139	2x25.5							
70025	2x22	114	2x30.5	144 grams							
7.0	70030	2x7	500	2x9.5	3.0 (mA)	34	25	74	49.7 x 49.7 x 23.1	45.72	1.0x0.5
	70031	2x9	389	2x12.2							
	70032	2x12	292	2x16.2							
	70033	2x15	233	2x20.3							
	70034	2x18	194	2x24.3							
70035	2x22	159	2x29.7	174 grams							
10.0	70040	2x7	714	2x8.3	3.0 (mA)	20	24	82	55.0 x 55.0 x 26.0	50.80	1.0x0.5
	70041	2x9	556	12x10.8							
	70042	2x12	417	2x14.4							
	70043	2x15	333	2x18.0							
	70044	2x18	278	2x21.7							
70045	2x22	227	2x26.3	252 grams							
15.0	70050	2x7	1071	2x8.9	4.0 (mA)	23	27	80	60.0 x 60.0 x 26.3	55.88	1.0x0.5
	70051	2x9	833	2x11.1							
	70052	2x12	625	2x14.8							
	70053	2x15	500	2x18.5							
	70054	2x18	417	2x22.2							
70055	2x22	341	2x27.2	304 grams							
25.0	70060	2x7	1785	2x8.3	5.0 (mA)	19	28	83	60.0 x 60.0 x 37.5	55.88	1.0x0.5
	70061	2x9	1377	2x10.7							
	70062	2x12	1041	2x14.3							
	70063	2x15	832	2x17.8							
	70064	2x18	694	2x21.4							
70065	2x22	568	2x26.2	435 grams							
35.0	70070	2x7	2500	2x8.0	7.0 (mA)	17.7	31	81	72.0 x 72.0 x 37.5	66.04	1.0x1.0
	70071	2x9	1944	2x10.6							
	70072	2x12	1458	2x14.0							
	70073	2x15	1167	2x17.6							
	70074	2x18	972	2x20.9							
70075	2x22	795	2x25.7	525 grams							
50.0	70080	2x7	3571	2x8.1	8.0 (mA)	15.5	30	86	82.4 x 82.4 x 37.5	76.20	1.0x1.0
	70081	2x9	2777	2x10.4							
	70082	2x12	2083	2x13.9							
	70083	2x15	1666	2x17.3							
	70084	2x18	1388	2x20.8							
70085	2x22	1136	2x25.4	685 grams							

Dimensions in mm. Electrical measurements at 20°C ambient temperature. All data subject to change without prior notice.

The attractive 70000-series PC Mount toroidal step-down transformers offer the design engineer the same features as our non-encapsulated toroidal power transformers, namely, very low EMR (magnetic strayfields), quiet operation, low temperature rise, low profile, low no-load current and very low no-load losses.

STANDARD FEATURES

- Primary voltage of 115V or 230V at 50 / 60Hz
- Safety standard certifications UL 506, UL 1950 (UL File #E145880), EN 60950, EN61558

- UL File #122978 recognized for insulation Class A (105 °C) Meets all requirements of Class E (125 °C)
- UL and VDE certifications to +40°C (1.6VA-25VA)
- Hipot testing at 4000V between primary and secondary (VDE0550)
- Maximum ambient temperature of +60°C for 1.6VA- 25VA, +40°C for 35VA and 50VA models

CUSTOM DESIGN OPTIONS

With minimum order of 1000 pieces custom specified primary and secondary voltages are available.

Please contact the Houston factory or your local Amveco sales representative for details.

WIRE DIAGRAM AND TERMINAL PIN LAYOUT

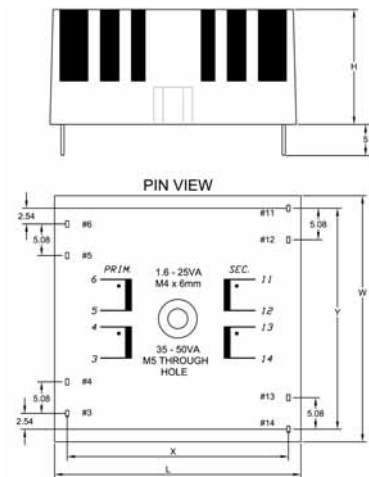

Power	L	W	H	X	Y	Weight	Pin
1.6	39.6	39.6	18.5	35.56	35.56	82 gr.	1.0x0.5
3.2	44.7	44.7	19.5	40.64	40.64	110 gr.	1.0x0.5
5.0	49.7	49.7	19.5	45.72	45.72	144 gr.	1.0x0.5
7.0	49.7	49.7	23.1	45.72	45.72	174 gr.	1.0x0.5
10.0	55.0	55.0	26.0	50.80	50.80	252 gr.	1.0x0.5
15.0	60.0	60.0	26.3	55.88	55.88	304 gr.	1.0x0.5
25.0	60.0	60.0	37.5	55.88	55.88	435 gr.	1.0x0.5
35.0	72.0	72.0	37.5	66.04	66.04	525 gr.	1.0x1.0
50.0	82.4	82.4	37.5	76.20	76.20	685 gr.	1.0x1.0

Dimensions in mm.

NOTES

- For 230 volt operation, connect primaries in series by connecting pins 5 & 4 together and apply 230 volts across pins 6 & 3.
- For 115 volt operation, connect primaries in parallel by connecting pins 6 & 4 together and pins 5 & 3 together; apply 115 volts across pins 6 & 5.
- To parallel the secondaries, connect pins 14 to 12 and 13 to 11; take the output across pins 14 and 13.
- To place the secondaries in series, connect pins 13 to 12 and take the output across pins 14 and 11.

Power VA	Part Number	Sec-Full Load V	Current mA	No Load Voltage	I No-Load	Reg. %	Δt °C	Eff %	Dim. ODxDxHT mm
1.6	62000	2x7	114	2x8.94	1.0 (mA)	29	10	77	37.5 x 7.0 x 17.0 71 grams
	62001	2x9	89	2x11.63					
	62002	2x12	67	2x15.43					
	62003	2x15	53	2x19.30					
	62004	2x18	44	2x23.41					
62005	2x22	36	2x28.19						
3.2	62010	2x7	229	2x10.2	1.5 (mA)	41	20	70	42.0 x 7.0 x 17.5 89 grams
	62011	2x9	178	2x13.0					
	62012	2x12	133	2x17.3					
	62013	2x15	107	2x21.4					
	62014	2x18	89	2x25.7					
62015	2x22	73	2x31.3						
5.0	62020	2x7	357	2x9.7	2.0 (mA)	45	29	70	47.0 x 6.0 x 18.0 115 grams
	62021	2x9	278	2x12.4					
	62022	2x12	208	2x17.0					
	62023	2x15	167	2x21.3					
	62024	2x18	139	2x25.5					
62025	2x22	114	2x30.5						
7.0	62030	2x7	500	2x9.5	3.0 (mA)	34	25	74	47.0 x 6.0 x 21.5 145 grams
	62031	2x9	389	2x12.2					
	62032	2x12	292	2x16.2					
	62033	2x15	233	2x20.3					
	62034	2x18	194	2x24.3					
62035	2x22	159	2x29.7						
10.0	62040	2x7	714	2x8.3	3.0 (mA)	20	24	82	53.5 x 6.8 x 23.5 216 grams
	62041	2x9	556	12x10.8					
	62042	2x12	417	2x14.4					
	62043	2x15	333	2x18.0					
	62044	2x18	278	2x21.7					
62045	2x22	227	2x26.3						
15.0	62050	2x7	1071	2x8.9	4.0 (mA)	23	27	81	57.5 x 7.0 x 24.0 262 grams
	62051	2x9	833	2x11.1					
	62052	2x12	625	2x14.8					
	62053	2x15	500	2x18.5					
	62054	2x18	417	2x22.2					
62055	2x22	341	2x27.2						
25.0	62060	2x7	1785	2x8.3	5.0 (mA)	19	28	84	58.0 x 13.8 x 34.5 388 grams
	62061	2x9	1377	2x10.7					
	62062	2x12	1041	2x14.2					
	62063	2x15	832	2x17.8					
	62064	2x18	694	2x21.4					
62065	2x22	568	2x26.2						
35.0	62070	2x7	2500	2x8.4	7.0 (mA)	17.7	31	85	72.0 x 17.0 x 33.5 453 grams
	62071	2x9	1944	2x10.6					
	62072	2x12	1458	2x14.0					
	62073	2x15	1166	2x17.6					
	62074	2x18	972	2x20.9					
62075	2x22	795	2x25.7						
50.0	62080	2x7	3571	2x8.1	8.0 (mA)	15.5	30	86	78.0 x 22.5 x 35.0 670 grams
	62081	2x9	2777	2x10.4					
	62082	2x12	2083	2x13.8					
	62083	2x15	1666	2x17.3					
	62084	2x18	1388	2x20.7					
62085	2x22	1136	2x25.4						

Dimensions in mm. Electrical measurements at 20°C ambient temperature. All data subject to change without prior notice.

The 62000-series Miniature toroidal step-down transformers offers the design engineer the same features as our larger toroidal power transformers, namely, very low EMR (magnetic strayfields), quiet operation, low temperature rise, low profile, low no-load current and very low no-load losses.

STANDARD FEATURES

- Primary voltage of 115V or 230V at 50 / 60Hz.
- Safety standard certification (UL 506), design construction meet UL 1950, VDE 0805, IEC 950, EN 60950.
- UL recognized for insulation Class A (105 °C). Meets all requirements of Class E (125 °C)
- UL certifications to + 40 °C (1.6VA-25VA)
- Hipot testing at 4000V between primary and secondary. (VDE0550)
- Maximum ambient temperature of + 60 °C
- Epoxy potted center with through hole for M4 bolt

CUSTOM DESIGN OPTIONS

With minimum order of 1000 pieces custom specified primary and secondary voltages are available. Please contact the Houston factory or your local Amveco sales representative for details.

WIRE DIAGRAM AND SCHEMATICS

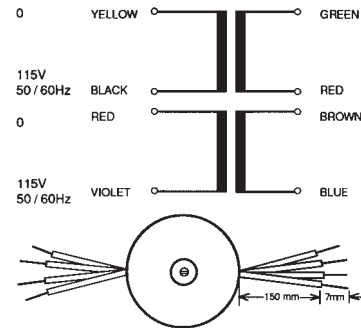

For 230V/240V operation, connect primaries in series by connecting black and red lead wires together and apply 230V across yellow and violet leads wires.

For 115V/120V operation, connect primaries in parallel by connecting yellow and red lead wires together and black and violet leads wires.

To parallel the secondaries, connect green and brown wires and red and blue together. To connect the secondaries in series, the red and brown wires are connected together. Take the output across the green and blue wires.

AMVECO STANDARD SERIES INDUCTORS



In addition to toroidal transformers, Amveco designs and manufactures toroidal chokes for DC-filtering and AC-circuits. As with transformers, toroidal chokes also offer significant savings in both size and weight compared to a laminated core. Presently, we manufacture chokes from 0.2 Ws to 25 Ws. AMVECO has developed its own design software which allows us to design and manufacture to your specific needs. With in-house capabilities for both core-making and core-cutting, we can offer fast turn-around for both prototypes and production units.



AMVECO Inductors

Part Number	Current I DC (A)	Current RMS	L (mH)	Power (WS)	Losses Core-Copper	OD x HT (Inches)	OD x HT (mm)	WT (lbs.)	WT (kg)
L0540	5	3.5	40	0.5	1.5 - 12.8	3.8 x 1.9	97 x 48	2.5	1.1
L0560	5	3.5	60	0.75	3 - 13.8	4.6 x 2.0	117 x 51	4	1.8
L1020	10	7	20	1	4 - 16.7	5.5 x 2.0	140 x 51	6	2.7
L1040	10	7	40	2	5 - 23.4	5.5 x 2.4	140 x 61	8	3.6
L1060	10	7	60	3	7 - 28.6	5.9 x 2.8	150 x 71	11.5	5.2
L1510	15	10.6	10	1.13	4 - 18.7	5.5 x 2.0	140 x 51	6	2.7
L1515	15	10.6	15	1.69	5 - 22.7	5.5 x 2.4	140 x 61	7.5	3.4
L1520	15	10.6	20	2.25	5 - 26.3	5.5 x 2.4	140 x 61	8	3.6
L1540	15	10.6	40	4.5	8 - 37.8	6.5 x 2.8	165 x 71	15	6.8
L2010	20	14.1	10	2	5 - 23.2	5.5 x 2.4	140 x 61	8	3.6
L2015	20	14.1	15	3	7 - 28.4	5.9 x 2.8	150 x 71	11.5	5.2
L2020	20	14.1	20	4	8 - 32.8	6.5 x 2.8	165 x 71	14	6.4
L2040	20	14.1	40	8	12 - 42.8	8.0 x 3.5	203 x 89	27	12.3
L3005	30	21.2	5	2.25	5 - 26.1	5.5 x 2.4	140 x 61	8.5	3.9
L3010	30	21.2	10	4.5	8 - 37.8	6.5 x 2.8	165 x 71	15	6.8
L3015	30	21.2	15	6.75	11 - 45.9	8.0 x 3.0	203 x 76	22	10.0
L3020	30	21.2	20	9	13 - 43.2	8.0 x 3.5	203 x 89	28	12.7
L4005	40	28.3	5	4	8 - 32	6.5 x 2.8	165 x 71	14	6.4
L4010	40	28.3	10	8	13 - 43.2	8.0 x 3.5	203 x 89	27	12.3
L4015	40	28.3	15	12	20 - 56	10 x 3.4	254 x 86	39	17.7
L5005	50	35.3	5	6.25	11 - 35	8.0 x 3.0	203 x 76	23	10.4
L5010	50	35.3	10	12.5	20 - 57.5	10.0 x 3.4	254 x 86	39	17.7
L6005	60	42.4	5	9	12 - 43.2	8.0 x 3.5	203 x 89	29	13.2

Substantial benefits may be derived from the use of toroids as long as thought is given to their application. The following two considerations are important.

A) Shorted Turn Condition

A completed path by any conductor passing through the center hole of the toroid around the outside constitutes a short circuited turn. As with any short circuit, this condition will result in high circulating currents and, more importantly, high heat.

Our standard mounting options utilize either a single bolt and large washer (disk mount) with no outside structure to act as a conductor, completing the circuit; or two metal flanges (flange mount) which clamp the toroidal like a sandwich with four bolts at the outer periphery, but nothing through the center. The L-Bracket and Clamping Bracket described are both designed to avoid a shorted turn condition.

B) Inrush Currents

The excellent magnetic properties of the toroidal transformer and the high remanence of the grain-oriented silicon steel, under certain circumstances, occasionally leads to high inrush current at turn-on.

To prevent nuisance interruptions due to blown fuses or supply breakers, some simple precautions should be considered. As the power rating of the transformer increases, the potential effect of the inrush current becomes greater. The following table suggests different types of circuit protection according to the toroid's power rating.

In addition, in those applications where an even lower in-rush current is desired, AMVECO has developed several proprietary construction techniques. Without added circuitry, both the peak value and the duration of the in-rush current can be reduced. As a matter of fact, AMVECO has manufactured toroidal transformers without any in-rush current at all. In these cases, AMVECO works closely with the customer to meet the specific requirements of the application. A slight increase in the overall size of the transformer is sometimes necessary to facilitate the lower in-rush current.

TRANSFORMER RATING	SUGGESTED PROTECTION
• 15 to 300VA	None
• 300VA to 1.0kVA	Slow-blow fuse in primary circuit
• 1.0 to 2.0kVA	Small value resistor in series with primary circuit
• 2.0kVA and up	Relay momentarily inserts resistor in primary circuit at start-up, or NTC Thermistors



Applying Part of the Insulation System

VISIT OUR WEBSITE FOR DESIGN SERVICE

Company: _____ Date: _____
 Contact Name: _____
 Address: _____ Telephone: _____
 City: _____ State: _____ Zip: _____ Fax: _____
 Email: _____
 Application: _____
 Customer P/N: _____ New Program Existing Program
 Quote Prices on: 1 10 25 50 100 250 500 1000 2500 5000 10000 25000

ELECTRICAL DATA

- Total Power Rating (VA): _____ Duty Cycle _____ %
- Input Voltages: 100V 120V 208V 230V 240V 277V Other: _____ V
- Line Frequency: 60Hz 50/60Hz Other: _____ Hz
- Thermal Protection: Auto Resettable Non-resettable
- Trip Temperature: _____ °C
- Maximum Temperature Rise Over Ambient: _____ °C
- Ambient Temperature: _____ °C

PHYSICAL DATA

- Maximum Diameter: _____ Maximum Height: _____ Not Critical
- Mounting Method: Standard Steel Washer/Insulating Pads L-Bracket for Vertical Mounting
 Potted Center Drilled Hole or Threaded Insert Enclosure
 Clamping Bracket Flanges Other _____
- Safety Agency Requirements: UL CSA IEC EN CE Medical
- Specify Which Safety Standard: _____

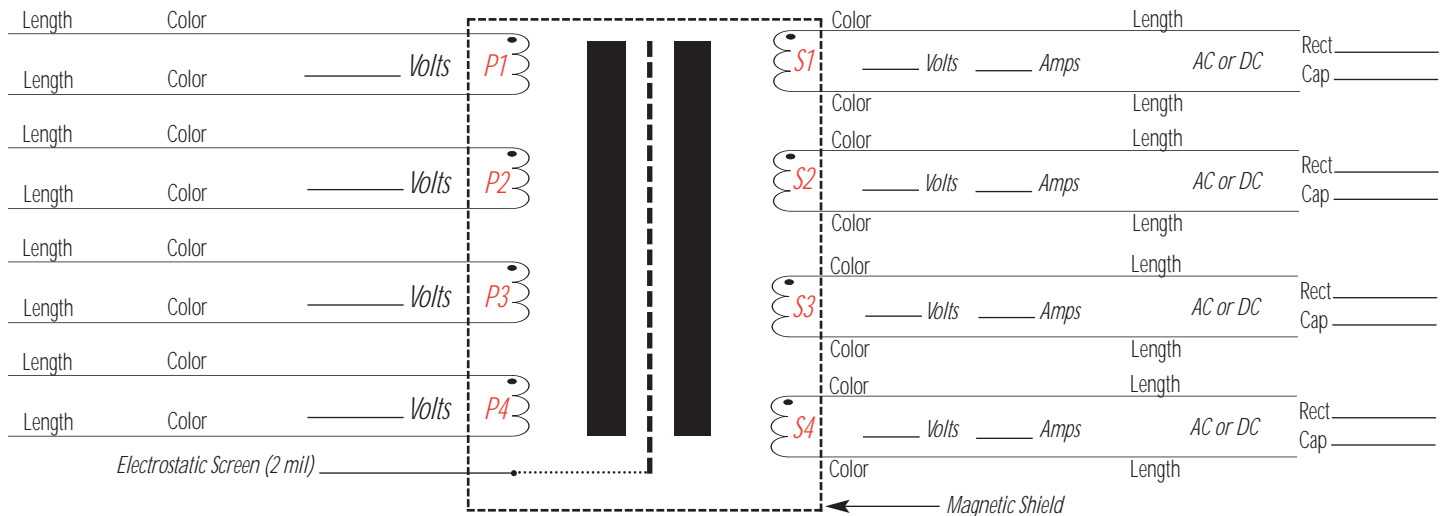

If DC values are listed, please tell us the type of rectifier circuitry and capacitance values.