

PART NO. SEE CHART
 DWG. NO. SDA-90151

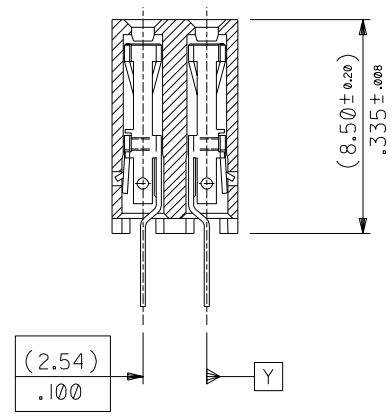

SECTION C-C

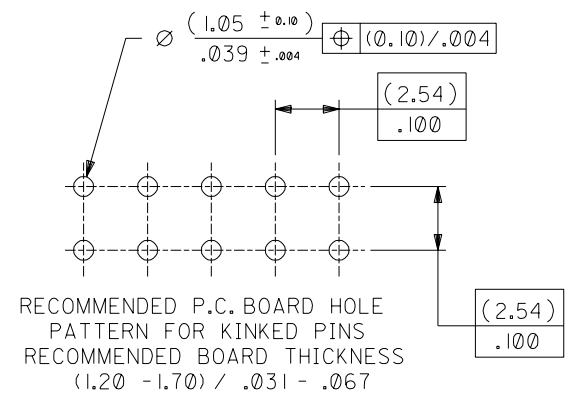
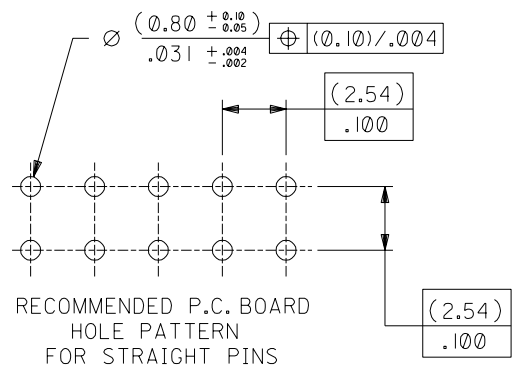
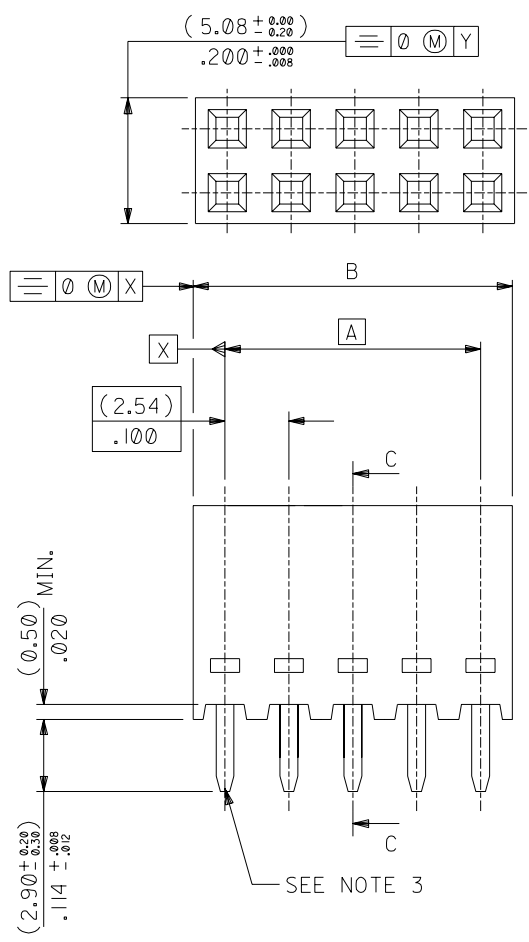
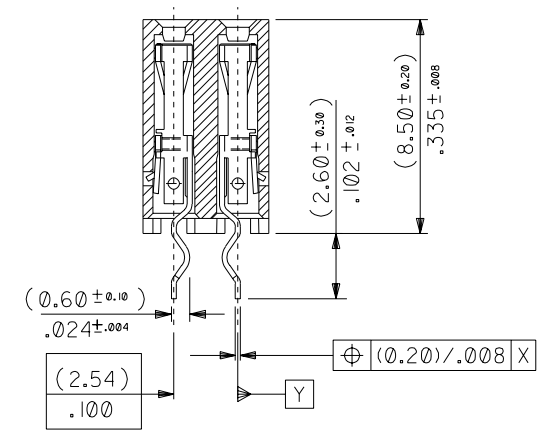

SECTION C-C

NOTES

- 1) CONTACT-PLATED PHOSPHOR BRONZE.
- 2) HOUSING-15% GLASS FILLED POLYESTER. COLOUR-BLACK.
- 3) COMPATIBLE WITH PCB HOLE PATTERN.
- 4) FOR (0.635)/.025 SQ. MALE PINS THE LENGTH MUST BE (5.65)/.222 MIN & (7.00)/.276 MAX. TO ENSURE GOOD CONNECTION WITH CONTACT.

FOR PREVIOUS DRAWING ISSUES SEE MRI.

MOD. TUBE QUANTITIES E2003-0061	TM 02/11/10	THIRD ANGLE PROJECTION		REVISE ONLY ON CAD SYSTEM	
		DIMENSIONS SHOWN (METRIC) INCH UNLESS OTHERWISE SPECIFIED TOLERANCES: ANGULAR ± 2°		CAD/CAM FILENAME SA90151X1 DGN	
AG	LTR	INCH (METRIC)		TITLE	
		3 PLACE ± . ---		C-GRID III DUAL ROW VERTICAL P.C. BOARD CONNECTOR	
REVISIONS		DRAFT WHERE APPLICABLE MUST REMAIN WITHIN DIMENSIONS		SHEET NO. DATE	
1 PLACE ± ---		DESIGN DIMENSION <input checked="" type="checkbox"/> (MM) (PRIMARY) <input type="checkbox"/> IN.		10F6 14/ 7/87	
2 PLACE ± . ---		EQUIVALENT DIMENSION <input type="checkbox"/> (MM) (SECONDARY) <input checked="" type="checkbox"/> IN.		PART NO. DWG NO. SIZE	
3 PLACE ± . ---		SCALE 5:1		SEE CHART SDA-90151 B	

6	AF
5	AD
4	AD
3	AD
2	AG
1	AG
SH.	REV.

10 9 8 7 6 5 4 3 2 1

SEE CHART
PART NO. SDA-90151
DWG. NO.

PART NO. STRAIGHT PINS	PART NO. KINKED PINS	NO. OF CKTS.	DIM. " A"	DIM. " B" (+0.00) (-0.30)	QTY. PER TUBE
90151-2X04	90151-3X04	4	(2.54) .100	(5.08) .200	105
▲▲06	▲▲06	6	(5.08) .200	(7.62) .300	72
08	08	8	(7.62) .300	(10.16) .400	52
10	10	10	(10.16) .400	(12.70) .500	44
12	12	12	(12.70) .500	(15.24) .600	36
14	14	14	(15.24) .600	(17.78) .700	30
16	16	16	(17.78) .700	(20.32) .800	26
18	18	18	(20.32) .800	(22.86) .900	24
20	20	20	(22.86) .900	(25.40) 1.000	22
22	22	22	(25.40) 1.000	(27.94) 1.100	20
24	24	24	(27.94) 1.100	(30.48) 1.200	18
26	26	26	(30.48) 1.200	(33.02) 1.300	16
28	28	28	(33.02) 1.300	(35.56) 1.400	14
30	30	30	(35.56) 1.400	(38.10) 1.500	14
32	32	32	(38.10) 1.500	(40.64) 1.600	13
34	34	34	(40.64) 1.600	(43.18) 1.700	12
36	36	36	(43.18) 1.700	(45.72) 1.800	12
38	38	38	(45.72) 1.800	(48.26) 1.900	11
40	40	40	(48.26) 1.900	(50.80) 2.000	11
42	42	42	(50.80) 2.000	(53.34) 2.100	11
44	44	44	(53.34) 2.100	(55.88) 2.200	10
46	46	46	(55.88) 2.200	(58.42) 2.300	10
48	48	48	(58.42) 2.300	(60.96) 2.400	9
50	50	50	(60.96) 2.400	(63.50) 2.500	8
52	52	52	(63.50) 2.500	(66.04) 2.600	8
54	54	54	(66.04) 2.600	(68.58) 2.700	8
56	56	56	(68.58) 2.700	(71.12) 2.800	7
58	58	58	(71.12) 2.800	(73.66) 2.900	7
60	60	60	(73.66) 2.900	(76.20) 3.000	7
▼▼62	▼▼62	62	(76.20) 3.000	(78.74) 3.100	7
90151-2X64	90151-3X64	64	(78.74) 3.100	(81.28) 3.200	6

PLATING VERSION A
PRE-PLATED HOT DIP TIN
1.0 TO 2.5 um (.000040" TO .000100").

PLATING VERSION E
1.27 TO 1.78 um (.000050" TO .000070") NICKEL
OVERALL, 0.38 TO 0.64 um (.000015" TO .000025")
GOLD ON CONTACT AREA (OVER NICKEL).
3 TO 5 um (.000120" TO .000200") TIN
ON SOLDER TAILS (OVER NICKEL).

PLATING VERSION F.
1.27 TO 1.78 um (.000050" TO .000070") NICKEL
OVERALL, 0.76 TO 1.0 um (.000030" TO .000040")
GOLD ON CONTACT AREA (OVER NICKEL).
3 TO 5 um (.000120" TO .000200") TIN
ON SOLDER TAILS (OVER NICKEL).

PLATING VERSION G.
1.27 TO 1.78 um (.000050" TO .000070") NICKEL
OVERALL, 0.125 um MIN. (.000005" MIN.) GOLD FLASH
ON CONTACT AREA (OVER NICKEL).
3 TO 5 um (.000120" TO .000200") TIN
ON SOLDER TAILS (OVER NICKEL).

PLATING VERSION N.
1.27 TO 1.78 um (.000050" TO .000070") NICKEL
OVERALL, 0.76 TO 2.6 um (.000030" TO .000100")
GOLD ON CONTACT AREA (OVER NICKEL).
4 um (.000120") MINIMUM TIN
ON SOLDER TAILS (OVER NICKEL).

STANDARD PRODUCTS

90151-XXYY

INDICATES NO. OF CIRCUITS.

- PLATING CODE.
1 = VERSION A.
2 = VERSION E.
3 = VERSION F.
4 = VERSION N.
5 = VERSION G.

SEE CHART

FOR PREVIOUS
DRAWING ISSUES
SEE MRI.

LEAD FREE CONVERSION
LEAD FREE ORDER NUMBER ADDED
EC NO. E2004-0610
DRAWN: PSHEAHAN 06/01/2004
CHK: APPR:
AH

DESCRIPTION
MAJOR
CRITICAL
REV

QUALITY SYMBOLS
GENERAL TOLERANCES:
(UNLESS SPECIFIED)
4 PLACES ±0. mm ±. INCH
3 PLACES ±0. mm ±. INCH
2 PLACES ±0. mm ±. INCH
1 PLACE ±0. mm ±. INCH
ANGULAR: ± °
DRAFT WHERE APPLICABLE MUST
REMAIN WITHIN DIMENSIONS

SCALE
DESIGN UNITS
 mm INCH
DRAWN BY & DATE
DB 14/ 7/87
CHECKED BY & DATE
APPROVED BY & DATE
CAD FILENAME SA9015IX2
DGN

THIRD ANGLE
PROJECTION
DIMENSIONS:
 mm INCH
 mm ONLY
TITLE:
C-GRID III
DUAL ROW VERTICAL
P.C. BOARD CONNECTOR
MOLEX MOLEX INCORPORATED
MATERIAL NO.
SEE CHART
DRAWING NO.
SDA-90151
SHEET NO.
20F

SHT REV
REVISE ON
CAD ONLY
THIS DRAWING CONTAINS INFORMATION THAT IS PROPRIETARY TO MOLEX
INCORPORATED AND SHOULD NOT BE USED WITHOUT WRITTEN PERMISSION.
SIZE
B

7132-1283 10 9 8 7 6 5 4 3 2 1