

LOC	DIST	REVISIONS					
		P	LTR	DESCRIPTION	DATE	DWN	APVD
E	B	A		FIRST ISSUE	17AUG05	JMS	FWK

- NOTES:
- ① SINGLE PACK IN ACCORDANCE WITH AMP SPEC 107-3275
 - ② 50 TRAY PACK IN ACCORDANCE WITH AMP SPEC 107-3275
 - ③ Au PLATING OVER Ni PLATING OVER Cu PLATING
 - ④ Ni PLATING OVER Cu PLATING
 - ⑤ TIN PLATING
 - ⑥ RECOMMENDED SELF-TAPPING SCREW 221108-4
 - 7. RECOMMENDED MOUNT NUT 1-1634816-0
 - 8. RECOMMENDED LOCKWASHER 1-1634817-0
 - 9. CHARACTERISTICS
 FREQUENCY RANGE: DC-2GHz
 NOMINAL IMPEDANCE: 75 OHMS
 WORKING VOLTAGE: 500V RMS
 INSULATION RESISTANCE: 5000 MOHMS
 DIELECTRIC WITHSTAND VOLTAGE: 1500V RMS
 CONTACT RESISTANCE: 1.5 mOHMS
 CENTRE CONTACT: 0.2 mOHMS
 OUTER CONTACT
 - 10. MECHANICAL CHARACTERISTICS
 DURABILITY: 50 CYCLES
 - 11. FOR TECHNICAL DATA REFER TO YOUR LOCAL TYCO ELECTRONICS SALES OFFICE
 - 12. ALL DIMENSIONS ARE NOMINAL FOR REFERENCE ONLY UNLESS OTHERWISE STATED

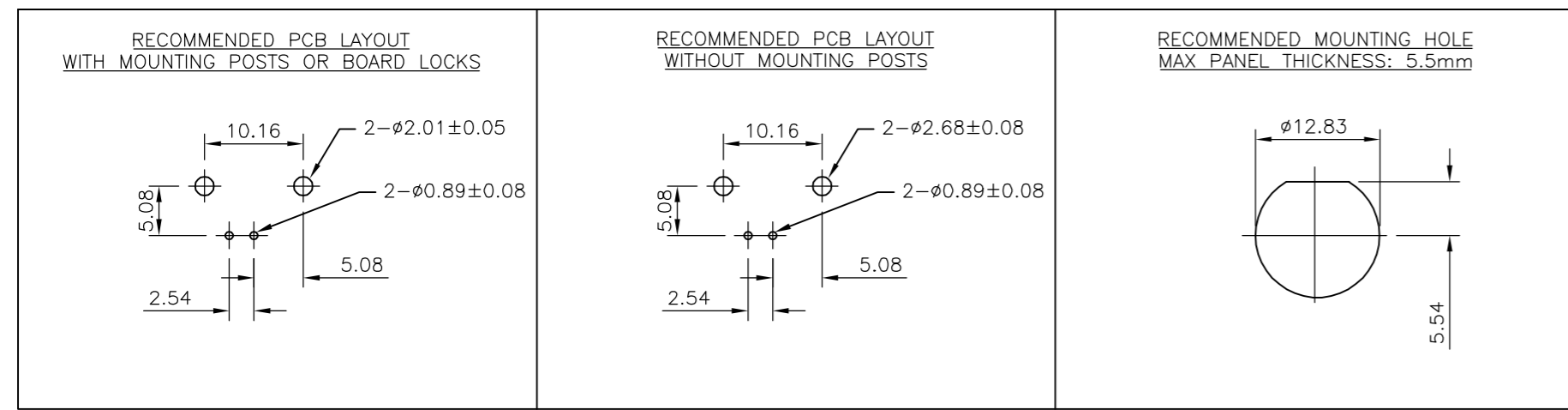
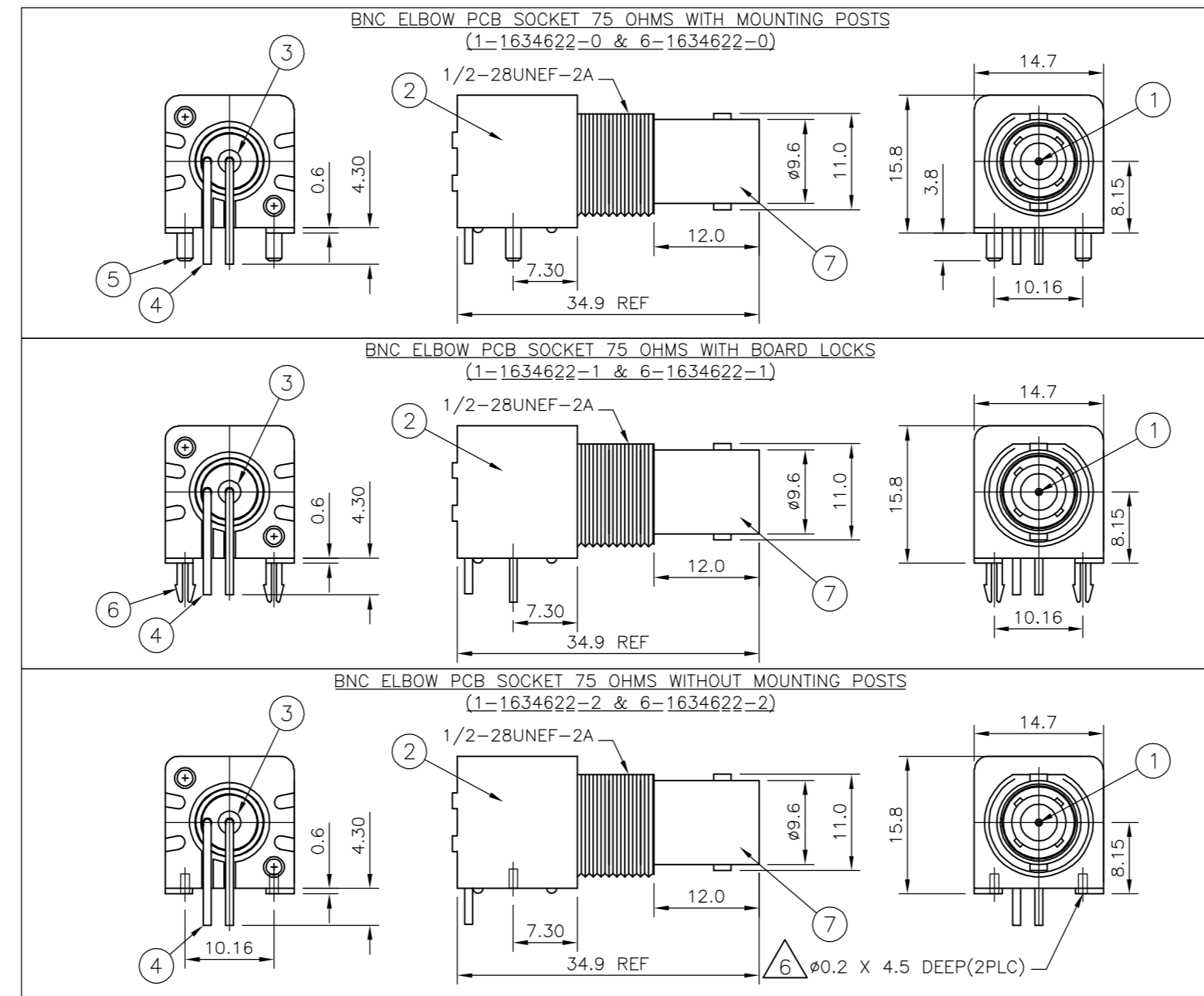

QTY	DESCRIPTION	MATERIAL	ITEM							
1	1	1	1	1	1	ZINC DIECAST	△	BODY	7	
-	-	2	2	-	-	BRASS	△	BOARD LOCK	6	
-	-	-	-	2	2	BRASS	△	MOUNTING POST	5	
1	1	1	1	1	1	BRASS	△	SOLDER TAIL	4	
1	1	1	1	1	1	PE-606		INSULATOR	3	
1	1	1	1	1	1	PBT BLACK		HOUSING	2	
1	1	1	1	1	1	BRASS	△	CONTACT	1	
6--2	1--2	6--1	1--1	6--0	1--0			MATERIAL	DESCRIPTION	ITEM

THIS DRAWING IS A CONTROLLED DOCUMENT.

DWN	J.SANDWELL	17AUG05
CHK	S.PARLOW	17AUG05
APVD	F.WHEELER-KING	17AUG05

NAME: BNC R/A INSULATED PCB SOCKET 75 OHM BLACK

PRODUCT SPEC: 108-3435

APPLICATION SPEC: N/A

WEIGHT: -

CUSTOMER DRAWING

SCALE: NTS

SHEET 1 OF 1

REV A

TYCO Electronics Tyco Electronics Corporation Bideford, UK, EX39 4HE

SIZE: A2 CAGE CODE: 00779 DRAWING NO: C=1634622 RESTRICTED TO: -