

HF **RoHS** **Pb** **GREEN** **SP1004 Lead-Free/Green Series**

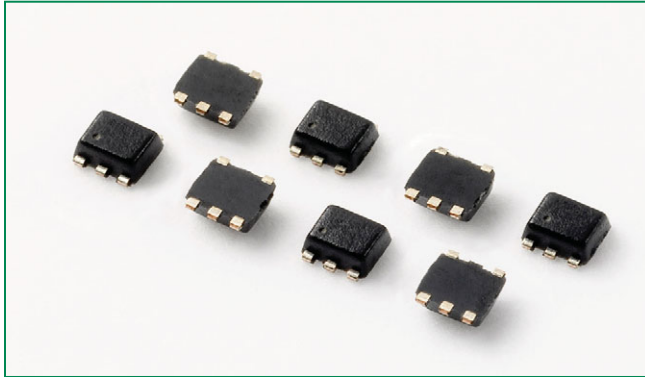

Description

Back-to-back zener diodes fabricated in a proprietary silicon avalanche technology protect each I/O pin to provide a high level of protection for electronic equipment that may experience destructive electrostatic discharges (ESD). These robust diodes can safely absorb repetitive ESD strikes at the maximum level specified in the IEC 61000-4-2 international standard (Level 4, ±8kV contact discharge) without performance degradation. Their very low loading capacitance also makes them ideal for protecting high-speed signal pins.

Pinout

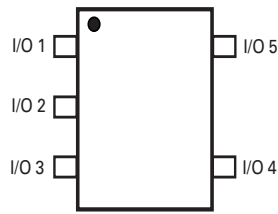

SOT953

NOTES:

¹Any of the 5 I/O pins can be tied to GND to provide 4 channels of bidirectional protection

Features

- ESD, IEC61000-4-2, ±8kV contact, ±15kV air
- Capable of withstanding >1,000 ±8kV ESD strikes
- Lightning, IEC61000-4-5, 2A ($t_p=8/20\mu s$)
- Low capacitance of 5pF (TYP) per I/O
- Low leakage current of 1µA (MAX) at 5V
- Small SOT953 package

Functional Block Diagram

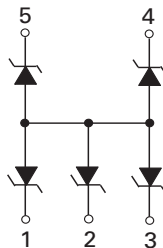

Applications

- MP3-PMPs
- DVD players
- Desktops
- Mobile phones
- Digital cameras
- Set top boxes
- Notebooks

Life Support Note:

Not Intended for Use in Life Support or Life Saving Applications

The products shown herein are not designed for use in life sustaining or life saving applications unless otherwise expressly indicated.

Absolute Maximum Ratings

Symbol	Parameter	Value	Units
I_{PP}	Peak Pulse Current ($t_p=8/20\mu s$)	2.0	A
T_{OP}	Operating Temperature	-40 to 85	°C
T_{STOR}	Storage Temperature	-60 to 150	°C

CAUTION: Stresses above those listed in "Absolute Maximum Ratings" may cause permanent damage to the device. This is a stress only rating and operation of the device at these or any other conditions above those indicated in the operational sections of this specification is not implied.

Thermal Information

Parameter	Rating	Units
Storage Temperature Range	-65 to 150	°C
Maximum Junction Temperature	150	°C
Maximum Lead Temperature (Soldering 10s)	260	°C

Electrical Characteristics ($T_{OP}=25^\circ C$)

Parameter	Symbol	Test Conditions	Min	Typ	Max	Units
Reverse Voltage Drop ¹	V_R	$I_R=1mA$	8.0	8.8	9.5	V
Reverse Standoff Voltage ¹	V_{RWM}	$I_R \leq 1\mu A$			6.0	V
Reverse Leakage Current ¹	I_{LEAK}	$V_R=5V$			0.1	μA
Clamp Voltage ²	V_C	$I_{PP}=1A, t_p=8/20\mu s$		10		V
		$I_{PP}=2A, t_p=8/20\mu s$		12		V
Dynamic Resistance	R_{DYN}	$(V_{C2} - V_{C1}) / (I_{PP2} - I_{PP1})$		2.0		Ω
ESD Withstand Voltage ^{1,2}	V_{ESD}	IEC61000-4-2 (Contact Discharge) ³	± 8			kV
		IEC61000-4-2 (Air Discharge)	± 15			kV
Diode Capacitance ^{1,2}	C_D	Reverse Bias=0V		6	7	pF
		Reverse Bias=1.5V		5	6	pF

Note: ¹ Parameter specified with pin 2 grounded externally.

² Parameter is guaranteed by design and/or device characterization.

³ Capable of withstanding >1,000 pulses at 1s intervals.

Capacitance vs. Reverse Bias

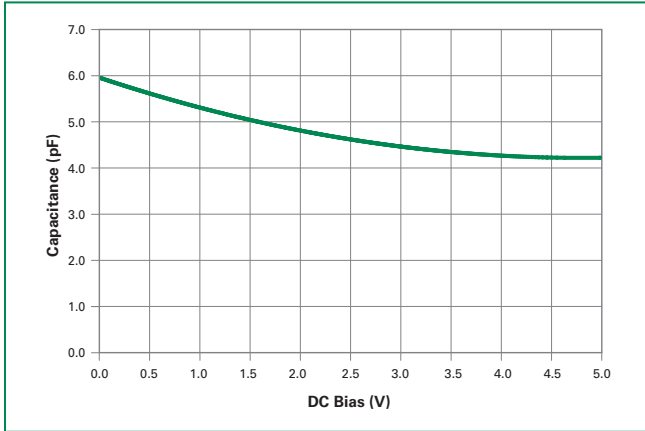

Insertion Loss (S21)

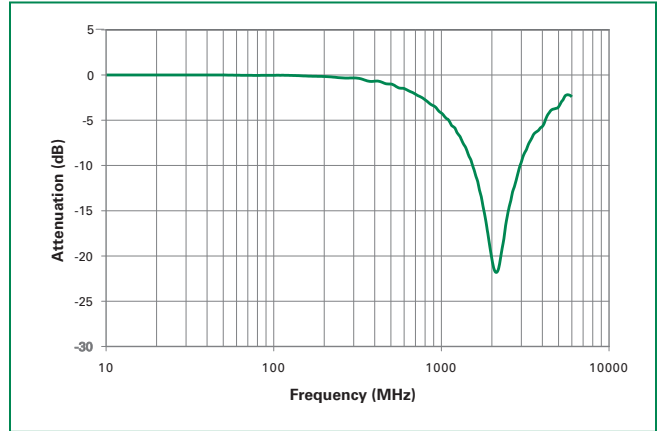

Lead-Free/Green SP1004

Application Example

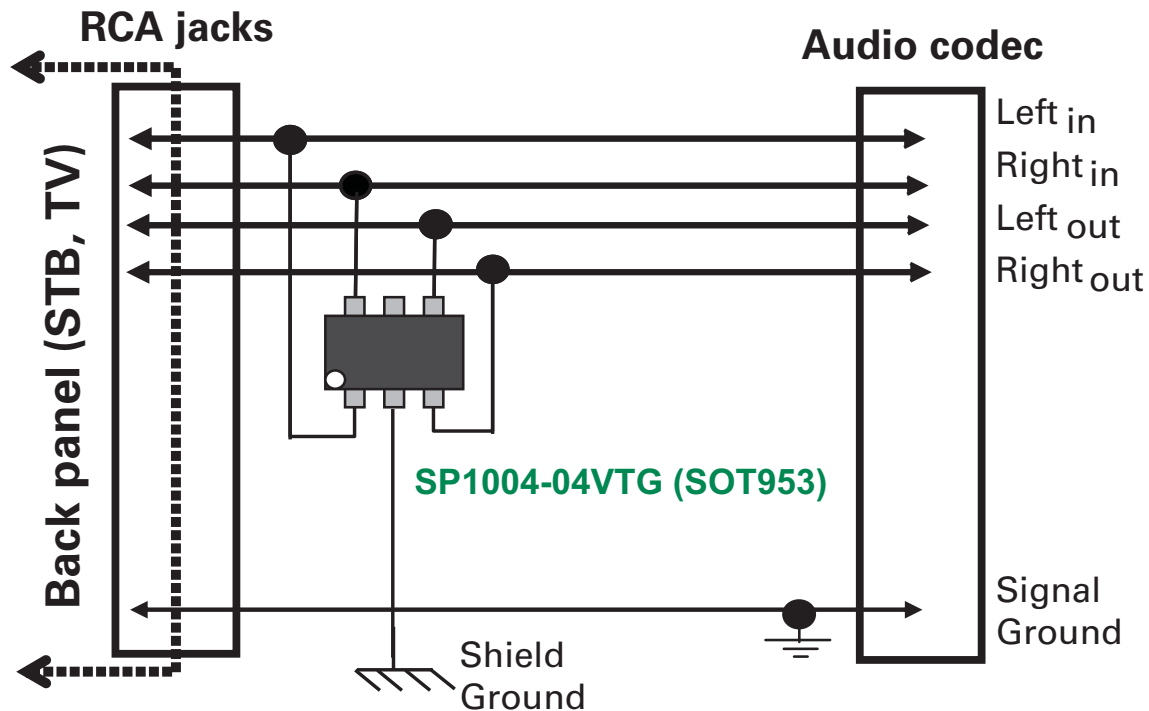

Soldering Parameters

Reflow Condition	Pb – Free assembly	
Pre Heat	- Temperature Min ($T_{s(min)}$)	150°C
	- Temperature Max ($T_{s(max)}$)	200°C
	- Time (min to max) (t_s)	60 – 180 secs
Average ramp up rate (Liquidus) Temp (T_L) to peak	3°C/second max	
$T_{s(max)}$ to T_L - Ramp-up Rate	3°C/second max	
Reflow	- Temperature (T_L) (Liquidus)	217°C
	- Temperature (t_L)	60 – 150 seconds
Peak Temperature (T_p)	250 ^{+0/-5} °C	
Time within 5°C of actual peak Temperature (t_p)	20 – 40 seconds	
Ramp-down Rate	6°C/second max	
Time 25°C to peak Temperature (T_p)	8 minutes Max.	
Do not exceed	260°C	

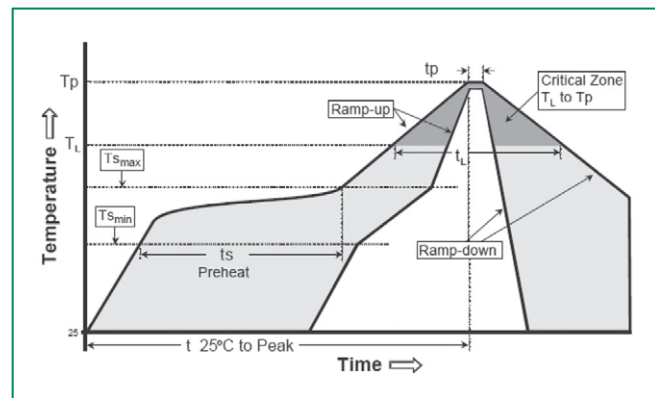

Package Dimensions - SOT953

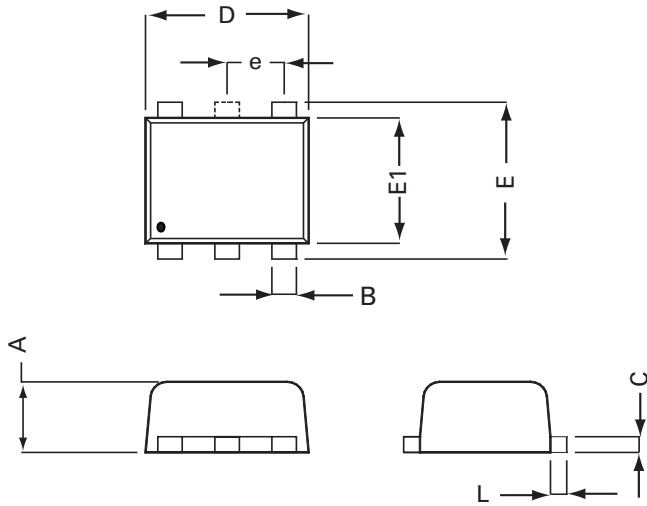

Symbol	SOT953			
	Millimeters		Inches	
	Min	Max	Min	Max
A	0.44	0.5	0.170	0.020
B	0.10	0.20	0.004	0.008
c	0.05	0.15	0.002	0.006
D	0.95	1.05	0.037	0.041
E	0.95	1.05	0.037	0.041
E1	0.75	0.85	0.029	0.033
e	0.35 BSC		0.014 BSC	
L	0.05	0.15	0.002	0.006

Lead-Free/Green SP1004

Part Numbering System

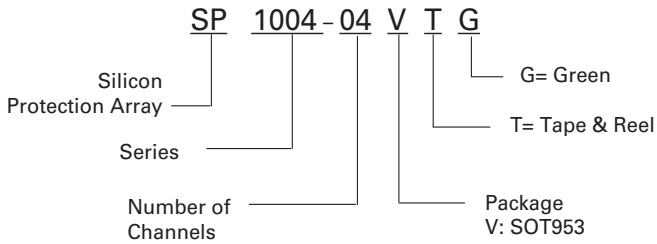

Product Characteristics

Lead Plating	Pre-Plated Frame
Lead Material	Copper Alloy
Lead Coplanarity	0.0004 inches (0.102mm)
Substitute Material	Silicon
Body Material	Molded Epoxy
Flammability	UL94-V-0

Notes :

1. All dimensions are in millimeters
2. Dimensions include solder plating.
3. Dimensions are exclusive of mold flash & metal burr.
4. All specifications comply to JEDEC SPEC MO-223 Issue A
5. Blo is facing up for mold and facing down for trim/form, i.e. reverse trim/form.
6. Package surface matte finish VDI 11-13.

Part Marking System

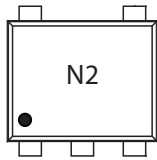

Ordering Information

Part Number	Package	Marking	Min. Order Qty.
SP1004-04VTG	SOT953	N2	8000

Embossed Carrier Tape & Reel Specification – SOT953

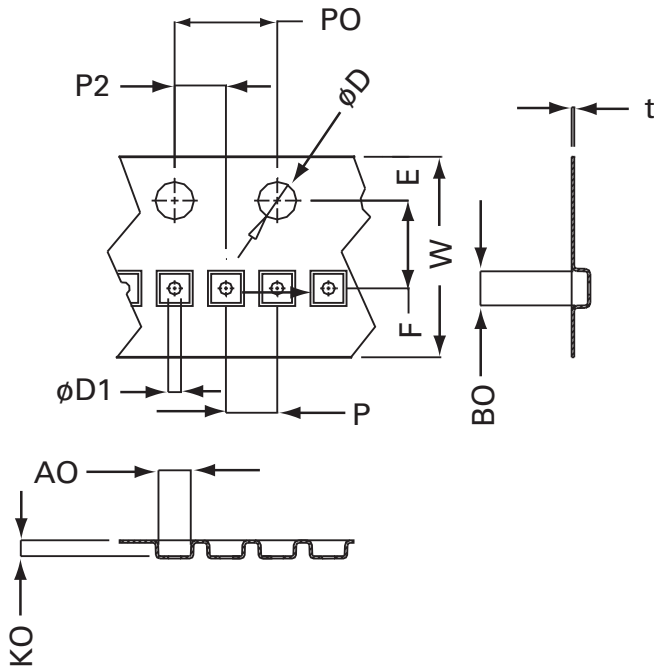

Symbol	Millimetres		Inches	
	Min	Max	Min	Max
E	1.65	1.85	0.065	0.073
F	3.45	3.55	0.136	0.140
D1	0.45	0.55	0.018	0.022
D	1.50 min		0.059 min	
P0	3.90	4.10	0.154	0.161
10P0	40.0 +/- 0.20		1.575 +/- 0.008	
P	1.95	2.05	0.077	0.081
P2	1.95	2.05	0.077	0.081
W	7.90	8.20	0.311	0.323
A0	1.11	1.21	0.044	0.048
B0	1.11	1.21	0.044	0.048
K0	0.58	0.68	0.023	0.027
t	0.22 max		0.009 max	