

# 36

## 36 Electronics Mounting Pliers

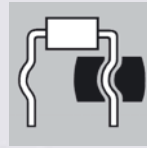

36 12 130



**Model 36 12 130:**  
to bend wire in shape for the distance to the plate



36 22 125

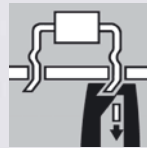

**Model 36 22 125:**  
to bend and cut wire at 1.6 mm length below the plate



36 32 125

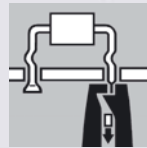

**Model 36 32 125:**  
to crunch and cut wire at 1.6 mm length below the plate



36 42 125 SB



**Model 36 42 125:**  
to cut wire at 1.3 mm length below the plate

- ▶ precision pliers for ultra fine assembly work, e. g. in electronics and fine mechanics
- ▶ for bending and cutting wire ends
- ▶ precision box joint
- ▶ smooth ground gripping surfaces
- ▶ edges carefully deburred
- ▶ low-friction double spring – for gentle and even opening
- ▶ the mirror polish together with a fine film of oil offer the best possible rust protection - no circuit faults caused by peeling chrome from plated tools
- ▶ special tool steel, oil-hardened and tempered

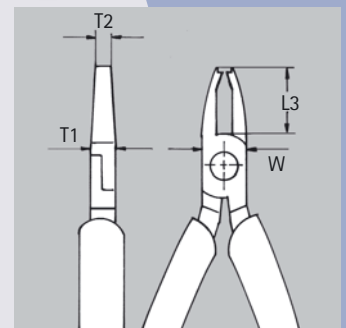
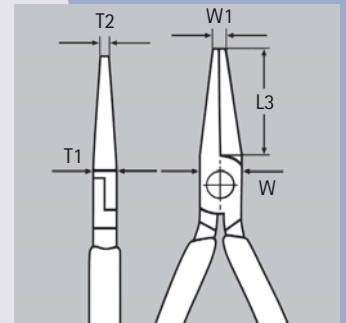

Article-No.	EAN-Code	Head	Handles	Style to	Dimensions						g
					L3	W	T1	W1	T2	⊙	
Length mm	4003773-				mm	mm	mm	mm	mm	mm	
36 12 130	016861	mirror polished	with two-colour	bend wire shape	23.0	12.0	7.5	5.5	6.0	-	80
36 22 125	046967		dual component handles	cut at 1.6 mm and bend wire	18.0	11.5	7.5	7.0	2.6	1.2	90
36 32 125	016885			cut at 1.6 mm and crunch wire	18.0	11.5	7.5	7.0	4.0	1.0	90
36 42 125 SB	016892			cut wire, distance 1.3 mm	18.0	11.5	7.5	-	4.0	1.2	100