

### Top View of Assembly

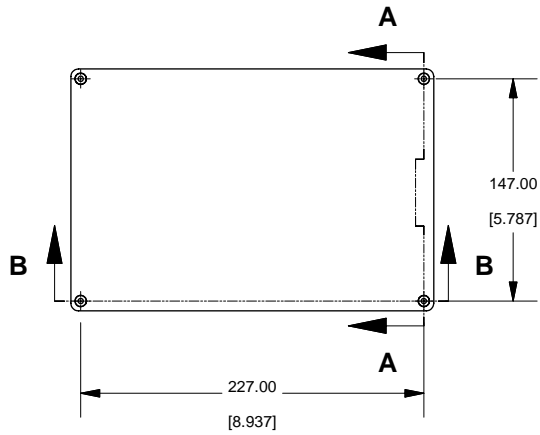

### SECTION A-A End View of Assembly

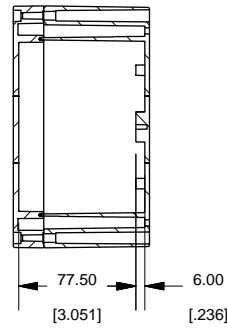

# 1554V

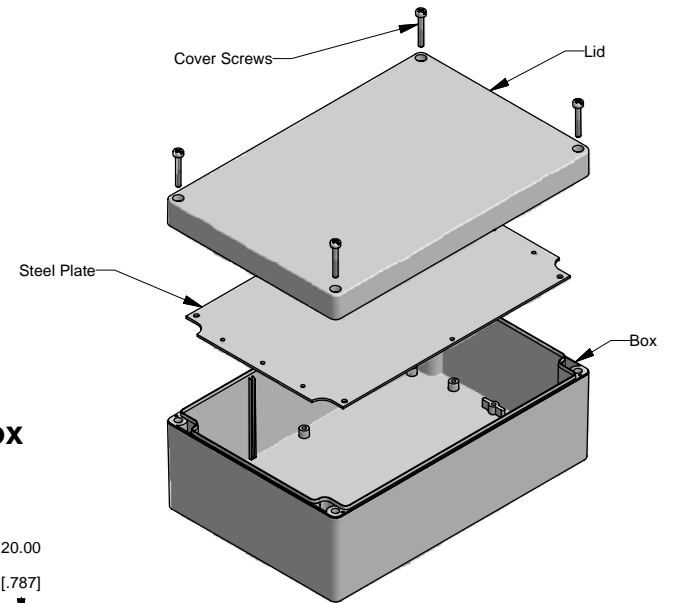

### SECTION B-B Side View of Assembly

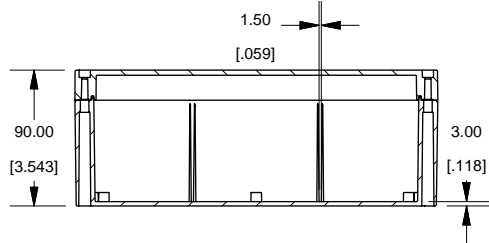

### Top View Looking Inside Box

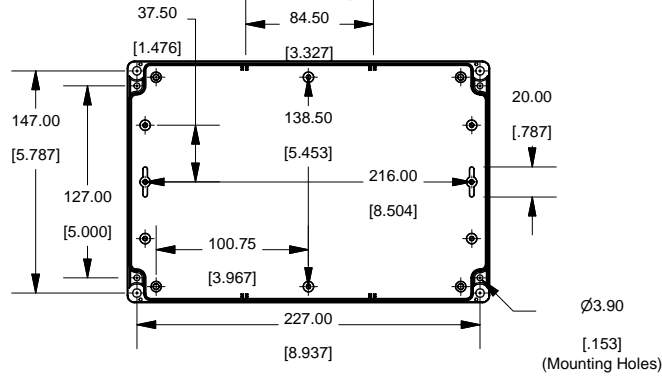

### Available 16 Gauge Steel Plate

### Maximum P.C. Board Size

NOTE: Hole patterns same as seen in top view of box.

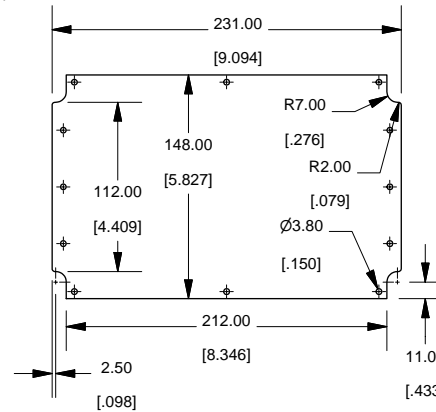
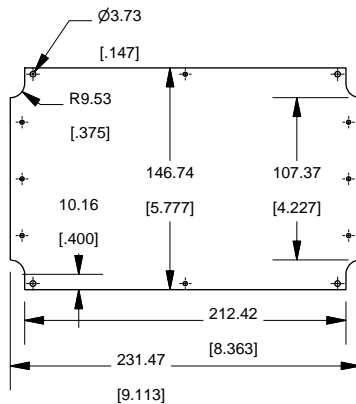

### Lid

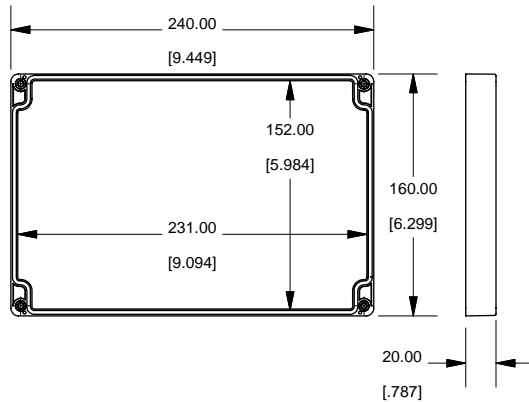

**NOTE**  
 Purchased assembly includes box, lid and 4 cover screws.  
 Cover screws should be torqued to 2.5 lbf-in (30 cN-m)  
 Polycarbonate version is 508 approved  
 Enclosure Type 4X, 4, 12 File# E65324

1554V	
1554V Enclosure	1554VGY
General Purpose ABS	1554V2GY
Polycarbonate	
1554V Clear Lid Enclosure	1554V2GYCL
Polycarbonate	
ACCESSORIES	
Heavy Duty 16 Gauge Galvanized Steel Panels	1554VPL
Steel Panel / P.C. Board Machine Screw [M3 X 8mm Nickel Plated]	1591MM100
Steel Panel / P.C. Board Self Tapping Screw [#6 X 1/4" (6.4mm) Nickel Plated]	1598ATS100
Cover Screws (Pkg 4)	
[M4 X 25mm Stainless Steel]	SC1554V

