

ZR431 Application Note

David Bradbury

The ZR431 is an enhanced version of the industry standard 431. It is a three terminal shunt regulator giving excellent temperature stability and the capability of operating at currents from 50µA up to 100mA. Its output voltage can be set to any voltage in the range of V_{ref} (2.5V) to 20V by the addition of two external divider resistors. The reference input current is typically only 100nA, so high value resistors can be used without error. Its minimum operating current and reference input current are ten times lower than industry standard 431 parts. (Please refer to Appendix A)

Following are a few example applications of the ZR431 which show how the parts can be used.

Shunt Regulator

The ZR431 is ideal for providing low voltage stabilised supplies or references. Simple low output voltage supplies can be difficult to build as the components normally used, such as zener diodes or band gap references, are either too poor in performance or not available at the desired voltage (band-gap devices are usually fixed at 2.5V or 5V with no intermediate values).

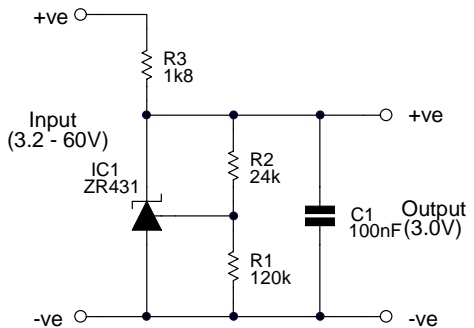

Figure 1
ZR431 used as a 3V Shunt Regulator.

The circuit in Figure 1 shows a 3V shunt regulator utilising the ZR431. The output of this supply can be set to any voltage in the range 2.5V to 20V by adjusting the ratio of R1 and R2, following the relationship:-

$$V_{out} = V_{ref} \frac{(R1+R2)}{R1}$$

Where V_{ref} is the reference voltage of the ZR431.

Note that a small correction to this formula is required if R1 and R2 are given very high values, since the reference input current of the ZR431

flows through R2 but not R1 thereby causing a small error. For the Zetex ZR431, this reference current is 200nA maximum so as long as a current of at least 20µA is passed through R1, setting its maximum value at 60k ohms, the reference current can be ignored. For very low current applications where it is advantageous to set R1 and R2 at a level where the reference current must be considered, the following formula takes input current into account:-

$$V_{out} = I_{ref} \times R2 + V_{ref} \frac{(R1+R2)}{R1}$$

Where I_{ref} is the reference input current of the ZR431.

R3 is selected so as to support the maximum load current at minimum input voltage, yet still maintain adequate operating current for the ZR431. Since the minimum cathode current of the ZR431 is only 50µA, it rarely has an effect on the choice of R3.

$$R3 = \frac{V_{in(min)} - V_{out}}{I_{out(max)} + I_{z(min)}}$$

Where $I_{z(min)}$ is the minimum cathode current of the ZR431.

The low series resistance of the ZR431 not only gives the shunt regulator good load regulation but also a line rejection of over 60dB. In this circuit, capacitor C1 both maintains this rejection figure at high frequencies and ensures stability should the power supply's load be capacitive. For the Zetex ZR431, a capacitor greater than 1.5nF will ensure stability for any load. (Competitors' versions of the '431 generally require values of 3.3µF or greater).

Switch-Mode Power Supply Controller

The circuit shown in Figure 2 is commonly used in the control loop of switch-mode power supplies. The output voltage is sensed via R3/R4 by the ZR431, and the IC controls the current passed through an opto-coupler and hence feeds back output voltage status to the switching regulator. The minimum supply voltage on which this popular circuit can be used is set by the minimum cathode voltage of the regulator IC, plus the forward voltage drop of the opto-coupler LED. This limits the minimum operating voltage of the circuit to around 4V.

The components C1 and R2 are not required for correct operation of the ZR431. They have been included as they are frequently needed to stabilise the overall control loop of the switch-mode power supply of which Figure 2 is only a part. **The ZR431 is unconditionally stable without additional components.**

Note 1:

Resistor R5 is only necessary if the minimum operating current of the ZR431 causes excess opto-coupler current before the reference functions correctly. The minimum operating current of the ZR431 is only 50µA so R5 is rarely required when using the Zetex part. (Competitors versions can pass in excess of 1mA before operating correctly, hence the occasional need for R5).

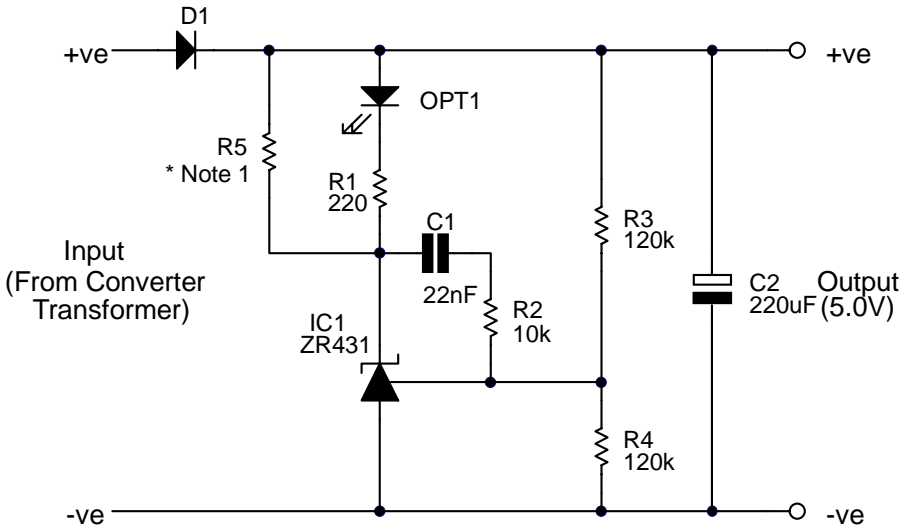

Figure 2
Control Loop of a Switched Mode Power Supply :
C1, R2 and R5 are Optional Components.

Series Regulator Power Supply

Although shunt regulators such as the circuit given in Figure 1 provide very simple and low cost power supplies, they are often inefficient because the pass resistor R3 must be selected to supply the maximum load expected at the minimum input voltage. When the actual load is lower or the input voltage is higher than for these worst-case conditions, excess current must be shunted away by the ZR431. This is not usually a problem for low output current supplies or when efficiency is not a major concern, but for loads greater than a few milliamps losses can be significant.

However, a series regulator can significantly reduce power losses and

hence improve efficiencies. Series regulators are usually much more complex than shunt circuits, requiring a reference, error amplifier, driver and series pass elements. However, it is possible to construct a very simple series regulator using a ZR431 to perform all but the pass transistor function. Figure 3 shows a series regulator for an automotive application. The circuit has been designed to provide 30mA at 5V to a microcontroller, to operate with a normal input supply range of 7V-15V, to withstand load-dump supply transients of 60V and a sustained overvoltage input of 24V, and tolerate reverse battery connection. All parts used are surface-mount so the supply can be constructed using little PCB area.

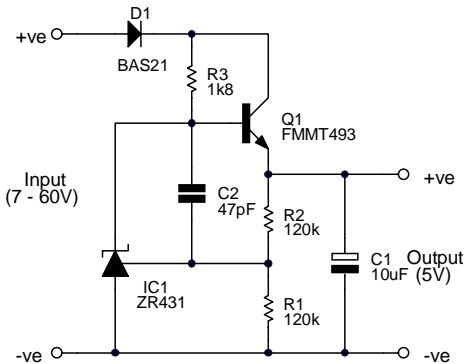

Figure 3
Series Regulator for Automotive Applications.

In this circuit, R3 provides base drive for the series pass transistor Q1. The ZR431 senses the output voltage of the supply via R1/R2, compares this with its internal reference and shunts excess base drive from Q1 so as to maintain the required supply output. Reverse polarity protection is provided by D1. The output resistance of the supply is around 20mΩ. Capacitor C1 helps maintain this very low output impedance at high frequencies. The stabilising capacitor C2 has been kept small so as not to degrade the excellent high frequency performance of the ZR431. The circuit will supply a 30mA load at minimum input and for higher inputs it can source much more. Note that the circuit does not include a current limit, and so care must be taken not to short the output for sustained periods.

The output of this type of supply can be set to any voltage in the range 2.5V to 20V by adjusting the ratio of R1 and R2, following the relationship:-

$$V_{out} = V_{ref} \frac{(R1+R2)}{R1}$$

Where Vref is the reference voltage of the ZR431.

It may be noticed, that this is the same formula give for the shunt regulator circuit in Figure 1. The comments concerning reference input current made for the shunt regulator also apply with this circuit.

R3 is selected so as to adequate base drive to Q1 at the minimum input voltage.

Temperature Coefficient Compensated Regulator

There are often occasions when a reference with a large and closely defined temperature coefficient (T.C.) are required. A common example of this is in the management of rechargeable batteries. Certain cell technologies such as Lithium and Lead-acid require charging to a set voltage to ensure they are fully charged. Failure to do this adequately can result in a reduction of battery life and in extreme cases, cell rupture. Unfortunately, this end of charge voltage varies with temperature and so the voltage reference controlling charge termination must be temperature compensated. Following is an example of how an accurate, low temperature coefficient regulator can be modified to produce a temperature compensated reference for lead-acid battery charging applications.

By adding a transistor with a known temperature coefficient to the reference input circuit of the ZR431, a reference

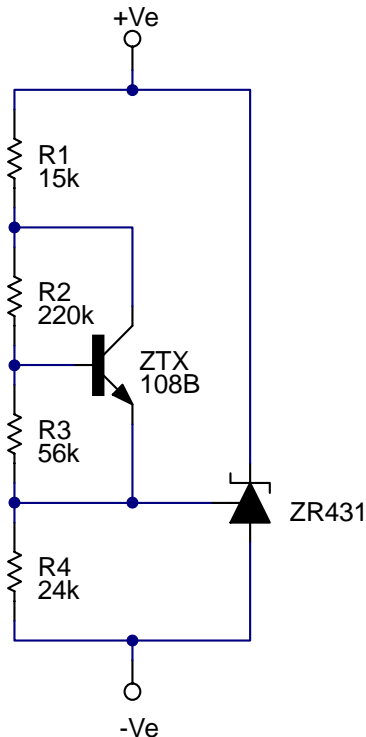

Figure 4
Temperature Coefficient Compensated Regulator.

with the same T.C. as the lead-acid batteries can be produced. Figure 4 shows a 6.9V shunt reference which has a T.C. of $-11.7\text{mV}/^\circ\text{C}$, matching a three cell lead-acid battery pack terminal voltage and temperature coefficient.

In this T.C. corrected reference circuit, the ratio of $R2/R3$ sets the overall temperature coefficient by amplifying the well characterised negative temperature coefficient of the ZTX108B

V_{be} . (The ratio will require modification should another transistor type be substituted). The ratio of $R1/R4$ has been adjusted to set the final output voltage to 6.9V at 25°C . The exceptionally low bias current of the ZR431 means that no allowance need be taken of the regulators reference input current in this circuit. Thanks to the low quiescent current of the ZR431, the shunt reference circuit will operate at currents down to less than $200\mu\text{A}$. Note, for best performance, the reference circuit should be situated close to the battery pack under charge to ensure temperature tracking.

Appendix A

Partial Characterisation of ZR431. Full Characterisation available within the “High Performance Linear Bipolar Integrated Circuits Data Book”.

ABSOLUTE MAXIMUM RATING

Cathode Voltage (V_Z)	20V	Power Dissipation ($T_{amb}=25^{\circ}C$)	
Cathode Current	150mA	SOT23	330mW
Operating Temperature	-40 to 85°C	TO92	780mW
Storage Temperature	-55 to 125°C	SOT223	2W
Recommended Operating Conditions		SO8	780mW
	Min	Max	
Cathode Voltage	V_{ref}	20V	
Cathode Current	50 μ A	100mA	

ELECTRICAL CHARACTERISTICS TEST CONDITIONS (Unless otherwise stated): $T_{amb}=25^{\circ}C$

PARAMETER	SYMBOL	VALUE			UNITS	CONDITIONS
		MIN	TYP	MAX		
Reference Voltage 2% 1%	V_{ref}	2.45 2.475	2.50 2.50	2.55 2.525	V	$I_L=10mA, V_Z=V_{ref}$
Deviation of Reference Input Voltage over Temperature	V_{dev}		8.0	17	mV	$I_L=10mA, V_Z=V_{ref}$ $T_a=full\ range$
Ratio of the change in Reference Voltage to the Change in Cathode Voltage	$\frac{\Delta V_{ref}}{\Delta V_Z}$		-1.85	-2.7	mV/V	V_Z from V_{ref} to 10V $I_Z=10mA$
			-1.0	-2.0	mV/V	V_Z from 10V to 20V $I_Z=10mA$
Reference Input Current	I_{ref}		0.12	1.0	μ A	$R1=10K, R2=O/C,$ $I_L=10mA$
Deviation of Reference Input Current over Temperature	ΔI_{ref}		0.04	0.2	μ A	$R1=10K, R2=O/C,$ $I_L=10mA T_a=full\ range$
Minimum Cathode Current for Regulation	I_{Zmin}		35	50	μ A	$V_Z=V_{ref}$
Off-state Current	I_{Zoff}			0.1	μ A	$V_Z=20V, V_{ref}=0V$
Dynamic Output Impedance	R_Z			0.75	Ω	$V_Z=V_{ref}, f=0Hz$