

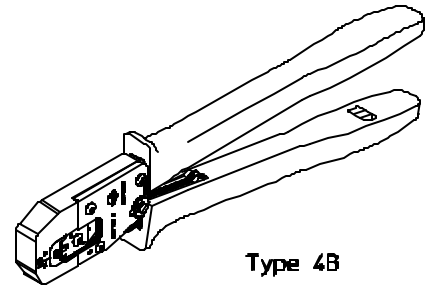

# TOOLING SPECIFICATION SHEET HAND CRIMP TOOL Part No. 63811-1500



Type 4B

## SCOPE

| Terminal Series No | Wire Size |                 | Insulation Diameter |            | Strip Length |           |
|--------------------|-----------|-----------------|---------------------|------------|--------------|-----------|
|                    | Awg       | mm <sup>2</sup> | mm                  | in         | mm           | in        |
| 42815-003*         | 8         | 8.50            | See Note 5          | See Note 5 | 9.00-10.00   | .354-.394 |
| 42817-0*3*         | 8         | 8.50            | See Note 5          | See Note 5 | 9.00-10.00   | .354-.394 |
|                    |           |                 |                     |            |              |           |
|                    |           |                 |                     |            |              |           |
|                    |           |                 |                     |            |              |           |

## CONDITIONS:

After crimping, the conductor profile should measure the following (see notes on page 2).

| Terminal Series No. | Wire Size |                 | Crimp Height (Ref) |           | Pull Force Min. |       | Punch Width |           | Profile 8 |
|---------------------|-----------|-----------------|--------------------|-----------|-----------------|-------|-------------|-----------|-----------|
|                     | Awg       | mm <sup>2</sup> | mm                 | in        | N               | Lbs.  | Ref. mm     | Cond Ins. |           |
| 42815-003*          | 8         | 8.50            | 3.20-3.30          | .126-.130 | 400.0           | 90.00 | 3.9         | N/A       | X         |
|                     |           |                 |                    |           |                 |       |             |           |           |
| 42817-0*3*          | 8         | 8.50            | 3.20-3.30          | .126-.130 | 400.0           | 90.00 | 3.9         | N/A       | X         |
|                     |           |                 |                    |           |                 |       |             |           |           |
|                     |           |                 |                    |           |                 |       |             |           |           |
|                     |           |                 |                    |           |                 |       |             |           |           |
|                     |           |                 |                    |           |                 |       |             |           |           |
|                     |           |                 |                    |           |                 |       |             |           |           |
|                     |           |                 |                    |           |                 |       |             |           |           |
|                     |           |                 |                    |           |                 |       |             |           |           |
|                     |           |                 |                    |           |                 |       |             |           |           |
|                     |           |                 |                    |           |                 |       |             |           |           |
|                     |           |                 |                    |           |                 |       |             |           |           |
|                     |           |                 |                    |           |                 |       |             |           |           |

## PARTS LIST

| Item Number | Order Number | Description | Qty |
|-------------|--------------|-------------|-----|
| 1           | 63811-1575   | Locator     | 1   |

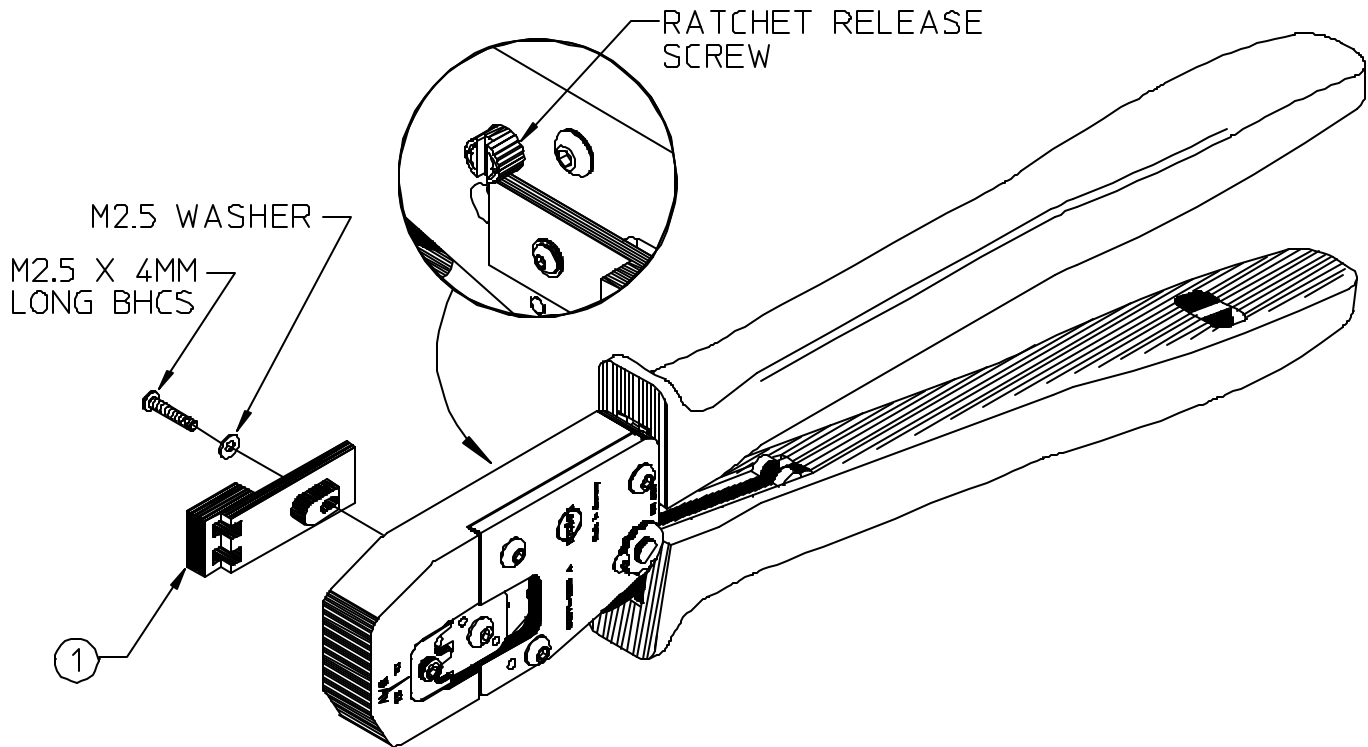

*Fig. 1*

### Notes:

1. This tool should only be used for the terminals and wire gauges specified on this sheet.
2. This tool is not adjustable. Variations in tools, terminals, wire strandings and insulation types may effect crimp height.
3. This tool is intended for standard conductor sizes. It may not give a good insulation crimp support for all insulation sizes.
4. Molex does not repair handtools (see warranty on next page) The replacment parts listed are the only parts available for repair. If the handles or crimp tooling is damaged or worn, a new tool must be purchased.
5. Pull force should be used as the final criteria for an acceptable crimp. Pull force is measured with no influence from the insulation crimp. ***On MiniFit Sr. 8 AWG applications the insulation is stripped in both the conductor and insulation grips.*** Refer to Molex Quality Crimping Handbook 63800-0029 for additional information on crimping and crimp testing.
6. Molex does not certify crimp handtools.
7. Hand held crimping tools are intended for low volume, prototyping, or repair requirements only.

**Caution:** Repetitive use of this tool should be avoided.

## Crimping Instructions

1. Open the tool by squeezing the handles together, at the end of the closing stroke, the ratchet mechanism will release the handles and the tool will spring open.
2. Place the terminal into the correct die profile (A or B) until it is stopped by the locator.
3. Partially close the tool until the terminal is held in place.
4. Place a wire into the terminal and align the wire with the conductor and insulation grips visually.
5. Close the tool until the ratchet releases.
6. Carefully remove the crimped terminal.

*Fig. 2*

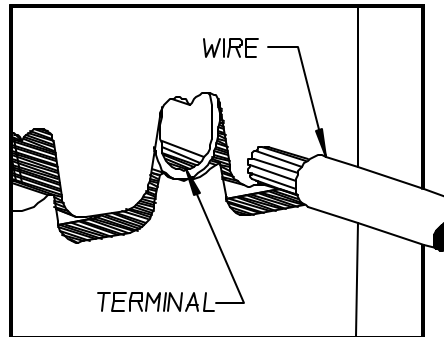

*Fig.3*

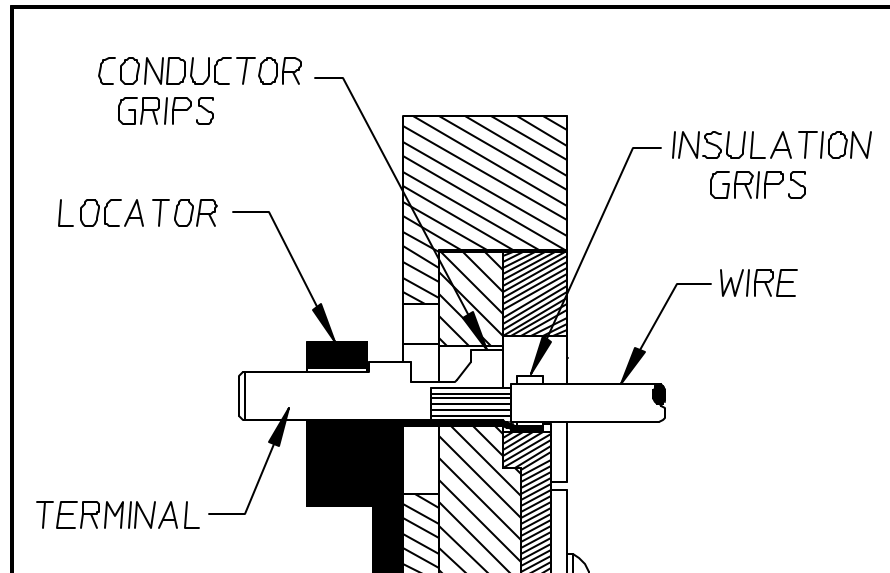

*Fig. 4*

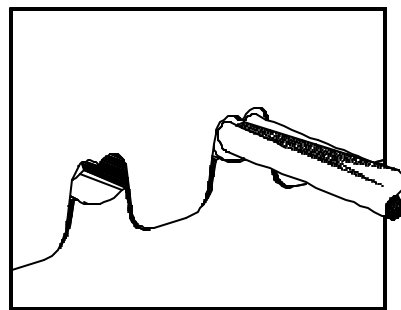

## **Maintenance**

It is recommended that each operator of the tool be made aware of, and responsible for, the following maintenance steps:

1. Remove dust, moisture and other contaminants with a clean brush, or soft, lint free cloth.
2. Do not use any abrasive materials that could damage the tool.
3. Make certain all pins, pivot points and bearing surfaces are protected with a thin coat of high quality machine oil. Do not oil excessively.
4. When tool is not in use, keep the handles closed to prevent objects from becoming lodged in the crimping dies, and store the tool in a clean, dry area.

## **Miscrimps or Jams (see Fig. 1 )**

Should this tool ever become stuck or jammed in a partially closed position, **Do Not** force the handles open or closed. The tool will open easily by rotating the slotted screw on the locator (back) side of the handtool.

## **Warranty**

This tool is for electrical terminal crimping purposes only. This tool is made of the best quality materials. All vital components are long life tested. All tools are warrantied to be free of manufacturing defects for a period of **30 days**. Should such a defect occur, we will exchange the tool free of charge. This will not be applicable to altered, misused, or damaged tools. This tool is designed for hand use only. Any clamping, fixturing, or use of handle extensions voids this warranty.

**Molex Application Tooling Group  
1150 E. Diehl Rd.  
Naperville, Il. 60563  
tel: 630-969-4550 fax: 630-505-0049**