

Low-Voltage Single SPDT Analog Switch

FEATURES

- Low Voltage Operation (+2.7 to +5 V)
- Low On-Resistance - $r_{DS(on)}$: 40 Ω
- Fast Switching - t_{ON} : 35 ns, t_{OFF} : 20 ns
- Low Leakage - $I_{COM(on)}$: 200-pA max
- Low Charge Injection - Q_{INJ} : 1 pC
- Low Power Consumption
- TTL/CMOS Compatible
- ESD Protection > 2000 V (Method 3015.7)
- Available in TSOP-6 and SOIC-8

BENEFITS

- Reduced Power Consumption
- Simple Logic Interface
- High Accuracy
- Reduce Board Space (TSOP-6)

APPLICATIONS

- Battery Operated Systems
- Portable Test Equipment
- Sample and Hold Circuits
- Cellular Phones
- Communication Systems
- Military Radio
- PBX, PABX Guidance and Control Systems

DESCRIPTION

The DG9461 is a single-pole/double-throw monolithic CMOS analog device designed for high performance switching of analog signals. Combining low power, high speed (t_{ON} : 35 ns, t_{OFF} : 20 ns), low on-resistance ($r_{DS(on)}$: 40 Ω) and small physical size (TSOP-6), the DG9461 is ideal for portable and battery powered applications requiring high performance and efficient use of board space.

The DG9461 is built on Vishay Siliconix's low voltage BCD-15 process. Minimum ESD protection, per Method 3015.7, is 2000 V. An epitaxial layer prevents latchup. Break-before-make is guaranteed for DG9461.

Each switch conducts equally well in both directions when on, and blocks up to the power supply level when off.

FUNCTIONAL BLOCK DIAGRAM AND PIN CONFIGURATION

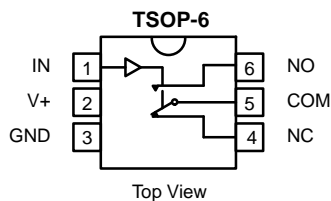

TRUTH TABLE		
Logic	NC	NO
0	ON	OFF
1	OFF	ON

Logic "0" \leq 0.8 V
Logic "1" \geq 2.4 V

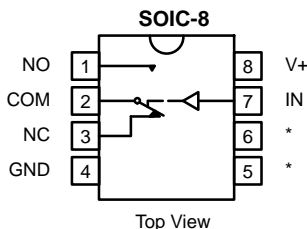

ORDERING INFORMATION		
Temp Range	Package	Part Number
-40 to 85°C	TSOP-6	DG9461DV
	SOIC-8	DG9461DY

*Not Connected



ABSOLUTE MAXIMUM RATINGS

Reference to GND

V+	-0.3 to +13 V
IN, COM, NC, NO ^a	-0.3 to (V+ + 0.3 V)
Continuous Current (Any terminal)	± 20 mA
Peak Current (Pulsed at 1ms, 10% duty cycle)	± 40 mA
ESD (Method 3015.7)	> 2000 V

Storage Temperature (D Suffix)	-65 to 125°C
Power Dissipation (Packages) ^b	
8-Pin Narrow Body SOIC ^c	400 mW

- Notes:
- Signals on S_X, D_X, or IN_X exceeding V+ or V- will be clamped by internal diodes. Limit forward diode current to maximum current ratings.
 - All leads welded or soldered to PC Board.
 - Derate 6.5 mW/°C above 75°C

SPECIFICATIONS (V+ = 3 V)							
Parameter	Symbol	Test Conditions Otherwise Unless Specified V+ = 3 V, ±10%, V _{IN} = 0.8 or 2.4 V ^e	Temp ^a	D Suffix -40 to 85°C			Unit
				Min ^c	Typ ^b	Max ^c	
Analog Switch							
Analog Signal Range ^d	V _{ANALOG}		Full	0		3	V
Drain-Source On-Resistance	r _{DS(on)}	V _{NO} or V _{NC} = 1.5 V, V+ = 2.7 V I _{COM} = 5 mA	Room Full		50	80 140	Ω
r _{DS(on)} Match ^d	Δr _{DS(on)}	V _{NO} or V _{NC} = 1.5 V	Room		0.4	2	
r _{DS(on)} Flatness ^f	r _{DS(on)} Flatness	V _{NO} or V _{NC} = 1 and 2 V	Room		4	8	
NO or NC Off Leakage Current ^g	I _{NO/NC(off)}	V _{NO} or V _{NC} = 1 V / 2 V, V _{COM} = 2 V / 1 V	Room Full	-100 -5000	5	100 5000	pA
COM Off Leakage Current ^g	I _{COM(off)}	V _{COM} = 1 V / 2 V, V _{NO} or V _{NC} = 2 V / 1 V	Room Full	-100 -5000	5	100 5000	
Channel-On Leakage Current ^g	I _{COM(on)}	V _{COM} = V _{NO} or V _{NC} = 1 V / 2 V	Room Full	-200 -10000	10	200 10000	
Digital Control							
Input Current	I _{INL} or I _{INH}		Full		1		μA
Dynamic Characteristics							
Turn-On Time	t _{ON}	V _{NO} or V _{NC} = 1.5 V	Room Full		50	120 200	ns
Turn-Off Time	t _{OFF}		Room Full		20	50 120	
Break-Before-Make Time	t _d		Room	3	20		
Charge Injection	Q _{INJ}	C _L = 1 nF, V _{gen} = 0 V, R _{gen} = 0 Ω	Room		1	5	pC
Off-Isolation	OIRR	R _L = 50 Ω, C _L = 5 pF, f = 1 MHz	Room		-74		dB
Source-Off Capacitance	C _{S(off)}	f = 1 MHz	Room		7		pF
Channel-On Capacitance	C _{D(on)}		Room		32		
Power Supply							
Power Supply Range	V+			2.7		12	V
Power Supply Current	I+	V+ = 3.3 V, V _{IN} = 0 or 3.3 V				1	μA

- Notes:
- Room = 25°C, Full = as determined by the operating suffix.
 - Typical values are for design aid only, not guaranteed nor subject to production testing.
 - The algebraic convention whereby the most negative value is a minimum and the most positive a maximum, is used in this data sheet.
 - Guarantee by design, not subjected to production test.
 - V_{IN} = input voltage to perform proper function.
 - Difference of min and max values.
 - Guaranteed by 5-V leakage testing, not production tested..



SPECIFICATIONS (V+ = 5 V)							
Parameter	Symbol	Test Conditions Otherwise Unless Specified V+ = 5 V, ±10%, VIN = 0.8 or 2.4 V ^e	Temp ^a	D Suffix -40 to 85°C			Unit
				Min ^c	Typ ^b	Max ^c	
Analog Switch							
Analog Signal Range ^d	V _{ANALOG}		Full	0		5	V
Drain-Source On-Resistance	r _{DS(on)}	V _{NO} or V _{NC} = 3.5 V, V+ = 4.5 V I _{COM} = 5 mA	Room Full		30	60 75	Ω
r _{DS(on)} Match ^d	Δr _{DS(on)}	V _{NO} or V _{NC} = 1.5 V	Room		0.4	2	
r _{DS(on)} Flatness ^f	r _{DS(on)} Flatness	V _{NO} or V _{NC} = 1, 2, and 3 V	Room		2	6	
NO or NC Off Leakage Current	I _{NO/NC(off)}	V _{NO} or V _{NC} = 1 V / 4 V, V _{COM} = 4 V / 1 V	Room Full	-100 -5000	10	100 5000	pA
COM Off Leakage Current	I _{COM(off)}	V _{COM} = 1 V / 4 V, V _{NO} or V _{NC} = 4 V / 1 V	Room Full	-100 -5000	10	100 5000	
Channel-On Leakage Current	I _{COM(on)}	V _{COM} = V _{NO} or V _{NC} = 1 V / 4 V	Room Full	-200 -10000		200 10000	
Digital Control							
Input Current	I _{INL} or I _{INH}		Full		1		μA
Dynamic Characteristics							
Turn-On Time	t _{ON}	V _{NO} or V _{NC} = 3.0 V	Room Full		35	75 150	ns
Turn-Off Time	t _{OFF}		Room Full		20	50 100	
Break-Before-Make Time	t _d		Room	3	10		
Charge Injection	Q _{INJ}	C _L = 1 nF, V _{gen} = 0 V, R _{gen} = 0 Ω	Room		2	5	pC
Off-Isolation	OIRR	R _L = 50 Ω, C _L = 5 pF, f = 1 MHz	Room		-74		dB
NC and NO Capacitance	C _(off)	f = 1 MHz	Room		-7		pF
Channel-On Capacitance	C _{D(on)}		Room		32		
Power Supply							
Power Supply Range	V+			2.7		12	V
Power Supply Current	I+	V+ = 5.5 V, V _{IN} = 0 or 5.5 V				1	μA

Notes:

- a. Room = 25°C, Full = as determined by the operating suffix.
- b. Typical values are for design aid only, not guaranteed nor subject to production testing.
- c. The algebraic convention whereby the most negative value is a minimum and the most positive a maximum, is used in this data sheet.
- d. Guarantee by design, nor subjected to production test.
- e. V_{IN} = input voltage to perform proper function.
- f. Difference of min and max values.



TYPICAL CHARACTERISTICS (25°C UNLESS NOTED)

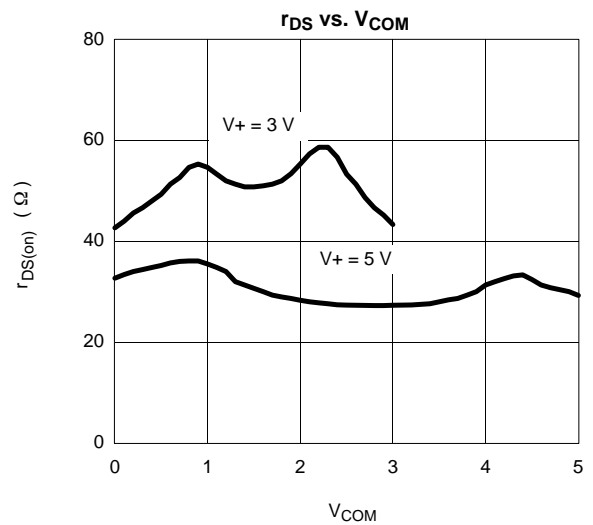
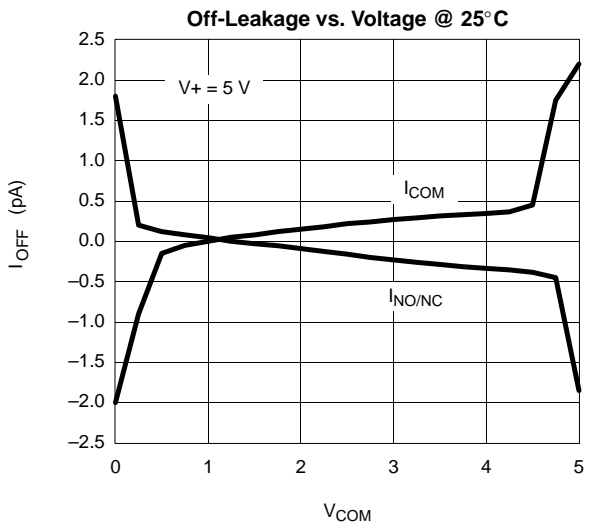
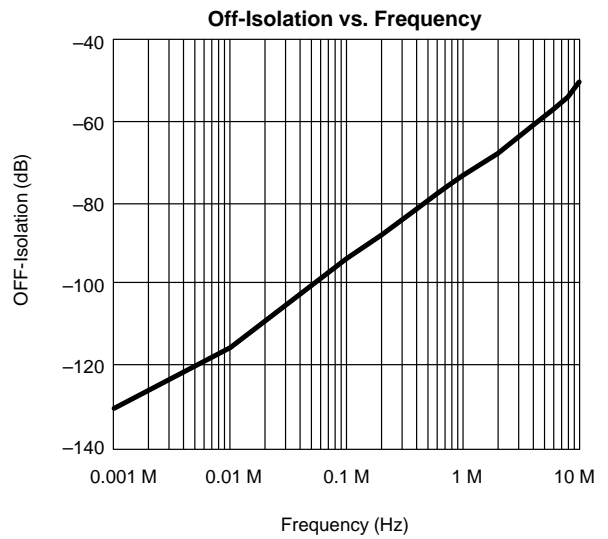
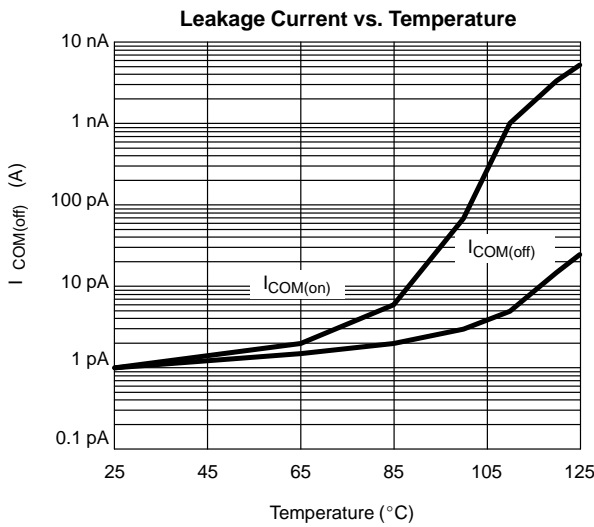
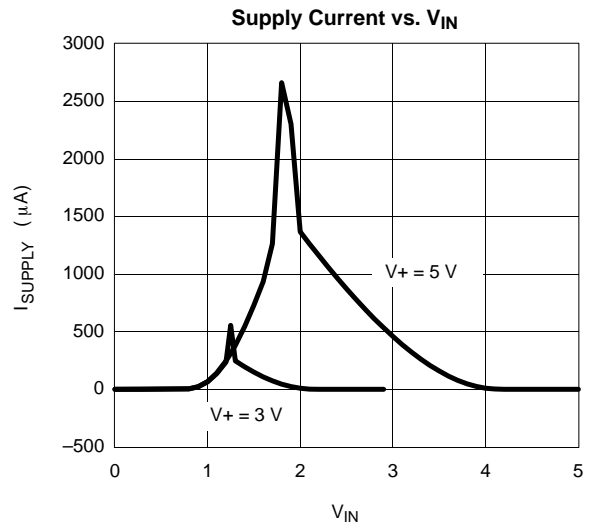
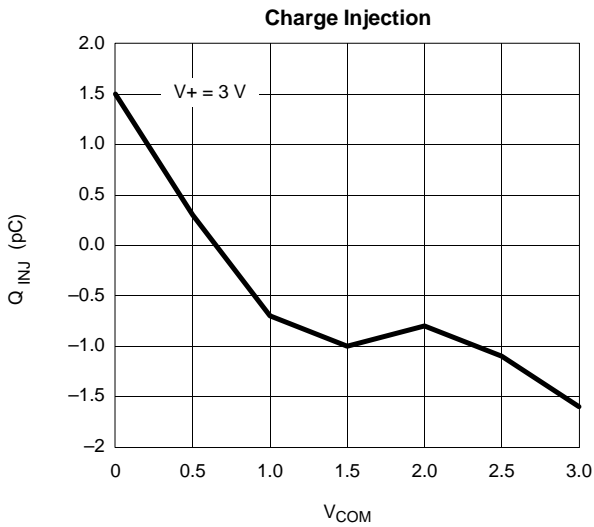



TYPICAL CHARACTERISTICS (25°C UNLESS NOTED)

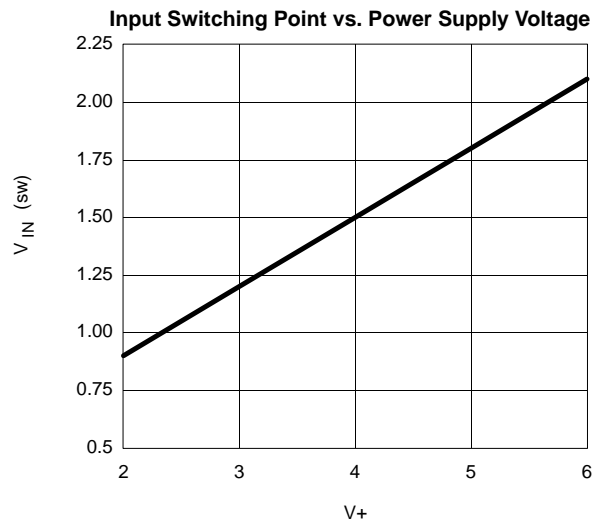
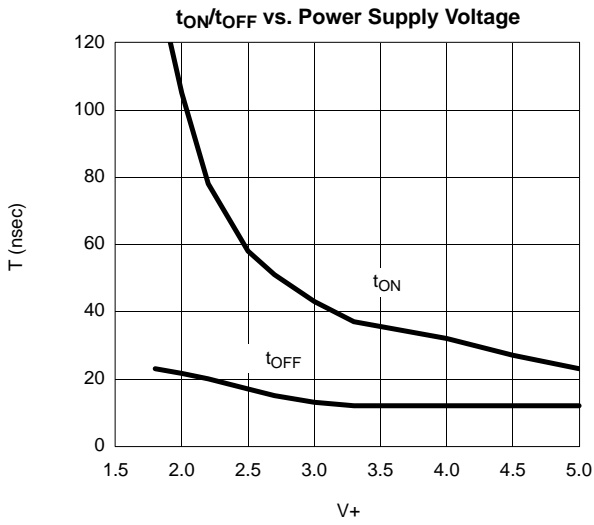
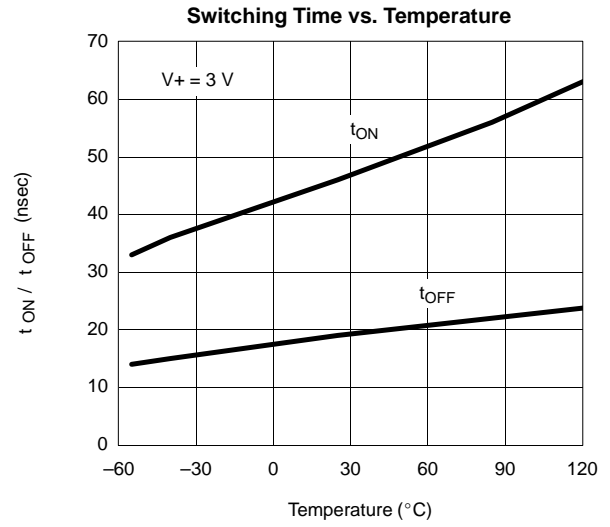
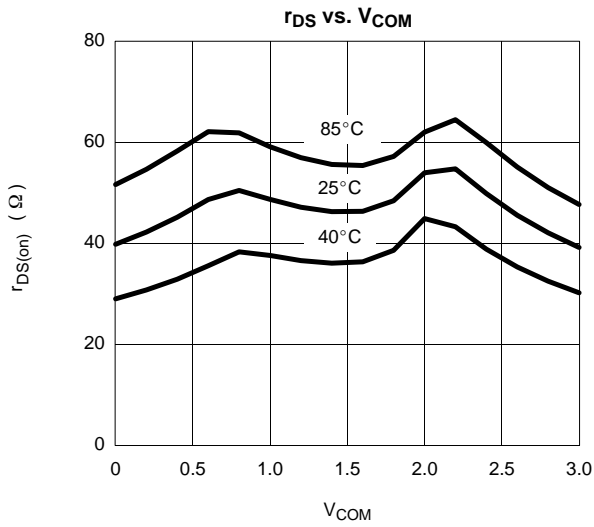

TEST CIRCUITS

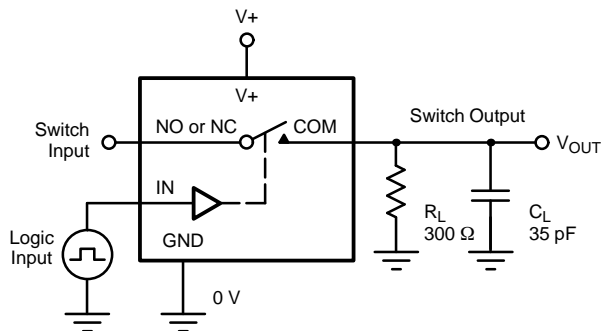

C_L (includes fixture and stray capacitance)

$$V_{OUT} = V_{COM} \left(\frac{R_L}{R_L + R_{ON}} \right)$$

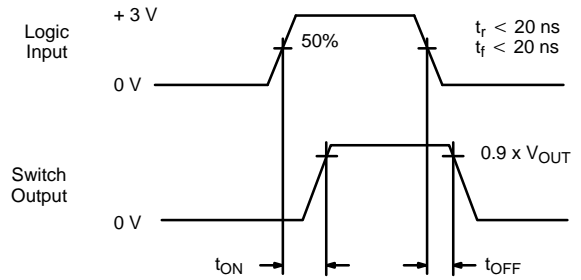

Logic "1" = Switch On
Logic input waveforms inverted for switches that have the opposite logic sense.

FIGURE 1. Switching Time

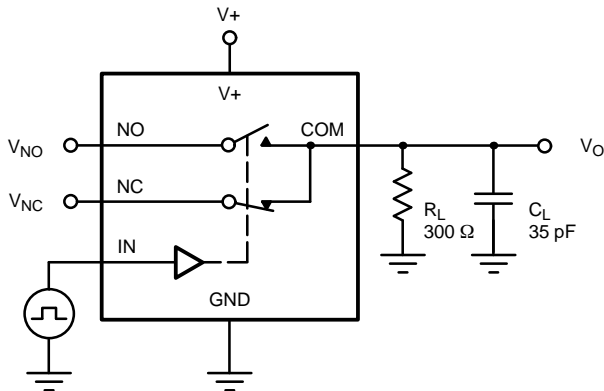

C_L (includes fixture and stray capacitance)

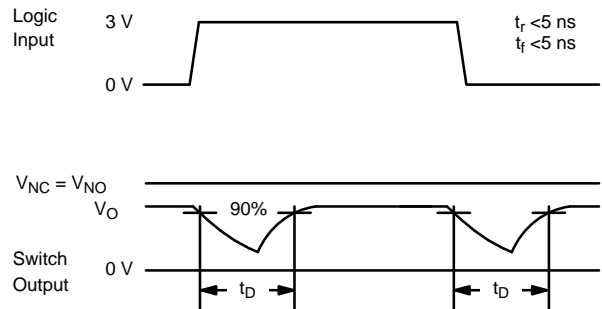
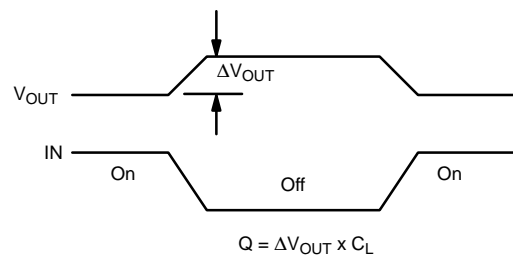
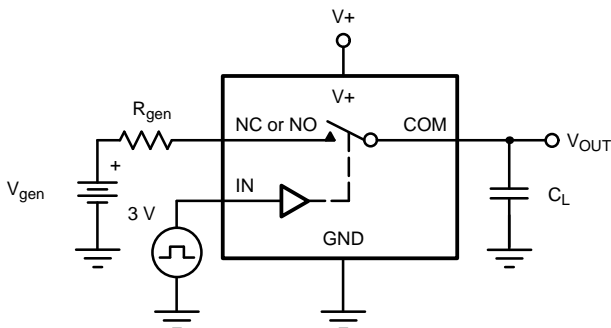

FIGURE 2. Break-Before-Make Interval



IN depends on switch configuration: input polarity determined by sense of switch.

FIGURE 3. Charge Injection

TEST CIRCUITS

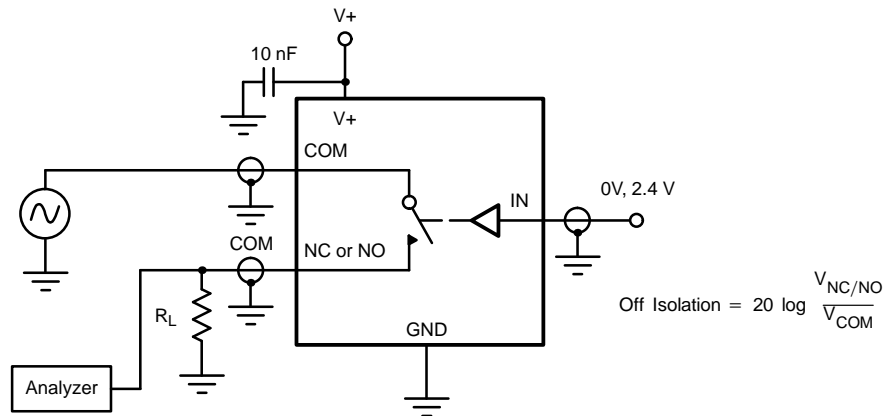

FIGURE 4. Off-Isolation

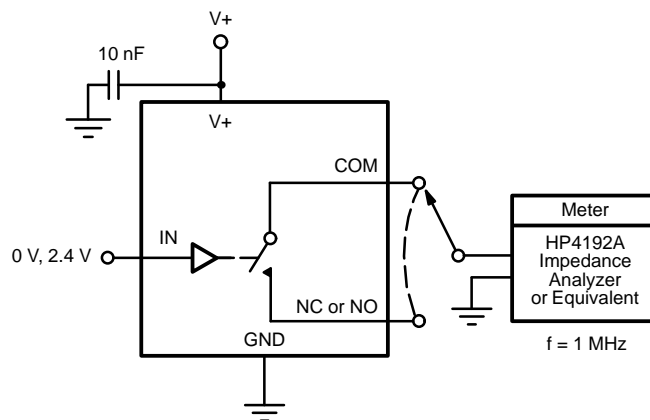

FIGURE 5. Channel Off/On Capacitance



Notice

Specifications of the products displayed herein are subject to change without notice. Vishay Intertechnology, Inc., or anyone on its behalf, assumes no responsibility or liability for any errors or inaccuracies.

Information contained herein is intended to provide a product description only. No license, express or implied, by estoppel or otherwise, to any intellectual property rights is granted by this document. Except as provided in Vishay's terms and conditions of sale for such products, Vishay assumes no liability whatsoever, and disclaims any express or implied warranty, relating to sale and/or use of Vishay products including liability or warranties relating to fitness for a particular purpose, merchantability, or infringement of any patent, copyright, or other intellectual property right.

The products shown herein are not designed for use in medical, life-saving, or life-sustaining applications. Customers using or selling these products for use in such applications do so at their own risk and agree to fully indemnify Vishay for any damages resulting from such improper use or sale.