

XC61C Series



Low Voltage Detectors ($V_{DF} = 0.8V \sim 1.5V$)
 Standard Voltage Detectors ($V_{DF} = 1.6V \sim 6.0V$)

◆ CMOS

- ◆ Highly Accurate : $\pm 2\%$
- ◆ Low Power Consumption : $0.7 \mu A$
($V_{IN} = 1.5V$)

■ APPLICATIONS

- Microprocessor reset circuitry
- Memory battery back-up circuits
- Power-on reset circuits
- Power failure detection
- System battery life and charge voltage monitors

■ GENERAL DESCRIPTION

The XC61C series are highly precise, low power consumption voltage detectors, manufactured using CMOS and laser trimming technologies.

Detect voltage is extremely accurate with minimal temperature drift.

Both CMOS and N-channel open drain output configurations are available.

■ FEATURES

- Highly Accurate** : $\pm 2\%$
- Low Power Consumption** : $0.7 \mu A$ (TYP.) [$V_{IN} = 1.5V$]
- Detect Voltage Range** : $0.8V \sim 1.5V$ in $100mV$ increments (Low Voltage)
: $1.6V \sim 6.0V$ in $100mV$ increments (Standard Voltage)
- Operating Voltage Range** : $0.7V \sim 6.0V$ (Low Voltage)
: $0.7V \sim 10.0V$ (Standard Voltage)
- Detect Voltage Temperature Characteristics** : $\pm 100ppm/^{\circ}C$ (TYP.)
- Output Configuration** : N-channel open drain or CMOS
- Ultra Small Packages** : SSOT-24 (150mW) super mini-mold
: SOT-23 (150mW) mini-mold
: SOT-89 (500mW) mini-power mold
: TO-92 (300mW)
: USP-6C (100mW)
: USP-4 (140mW)

■ TYPICAL APPLICATION CIRCUITS

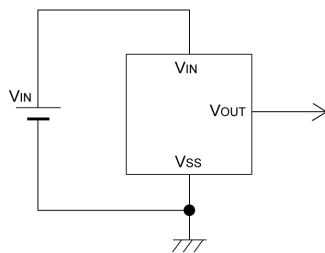

CMOS Output

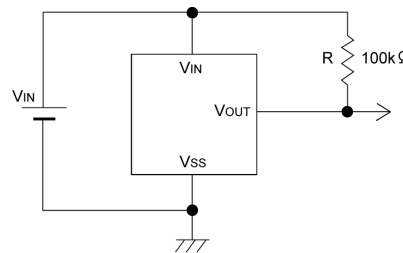

N-ch Open Drain Output

■ TYPICAL PERFORMANCE CHARACTERISTICS

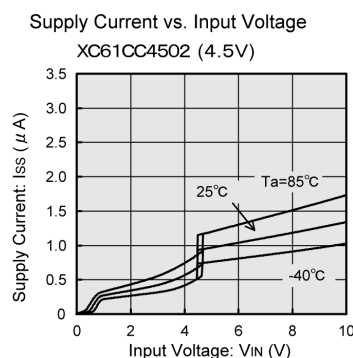
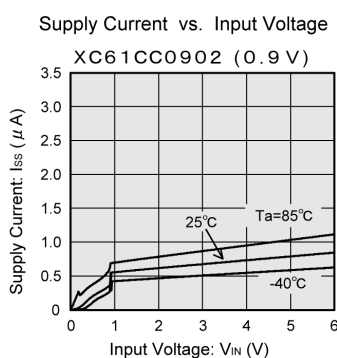

PIN CONFIGURATION

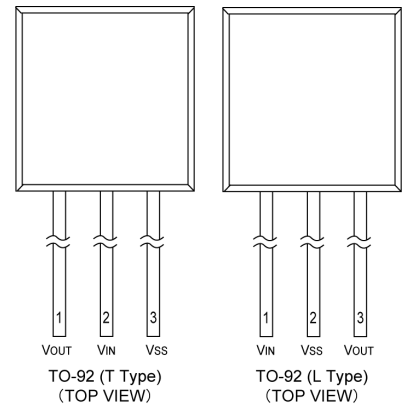
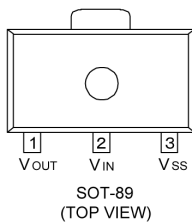
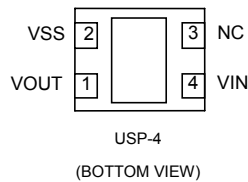
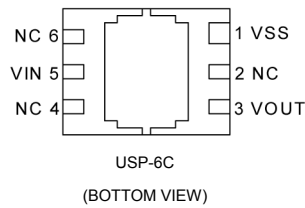
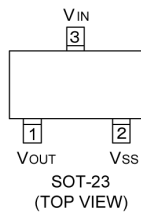
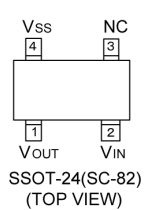

*Please use the circuit without connecting the heat dissipation pad. If the pad needs to be connected to other pins, it should be connected to the VIN pin.

PIN ASSIGNMENT

PIN NUMBER							PIN NAME	FUNCTION
SSOT-24	SOT-23	SOT-89	TO-92 (T)	TO-92 (L)	USP-6C	USP-4		
2	3	2	2	1	5	4	VIN	Supply Voltage
4	2	3	3	2	1	2	VSS	Ground
1	1	1	1	3	3	1	VOUT	Output
3	-	-	-	-	2,4,6	3	NC	No Connection

PRODUCT CLASSIFICATION

Ordering Information

XC61C①②③④⑤⑥⑦

DESIGNATOR	DESCRIPTION	SYMBOL	DESCRIPTION
①	Output Configuration	C	: CMOS output
		N	: N-ch open drain output
② ③	Detect Voltage	08 ~ 60	: e.g.0.9V → ②0, ③9
			: e.g.1.5V → ②1, ③5
④	Output Delay	0	: No delay
⑤	Detect Accuracy	2	: Within $\pm 2\%$
⑥	Package	N	: SSOT-24 (SC-82)
		M	: SOT-23
		P	: SOT-89
		T	: TO-92 (Standard)
		L	: TO-92 (Custom pin configuration)
		D	: USP-6C
⑦	Device Orientation	G	: USP-4
		R	: Embossed tape, standard feed
		L	: Embossed tape, reverse feed
		H	: Paper type (TO-92)
		B	: Bag (TO-92)

PACKAGING INFORMATION

●SSOT-24 (SC-82)

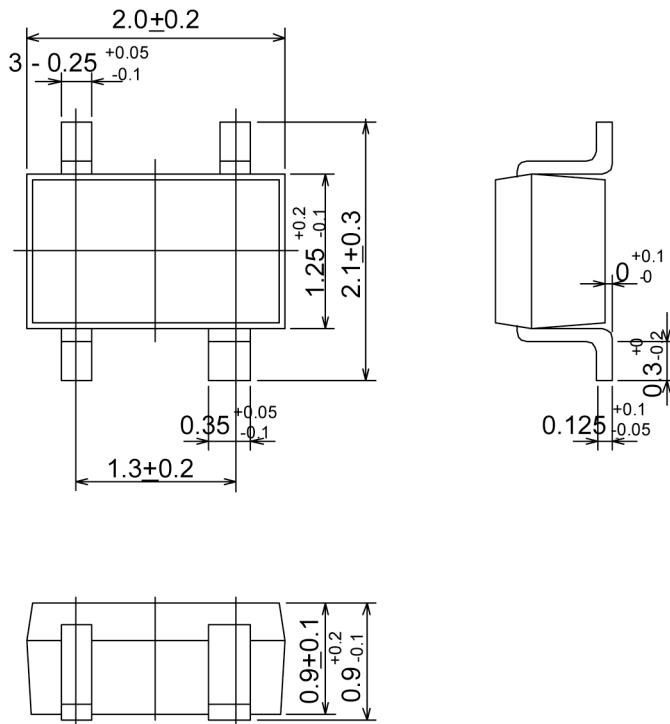

●SOT-23

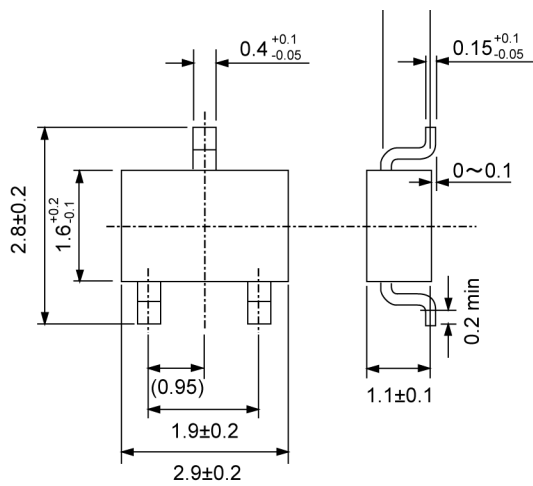

■ PACKAGING INFORMATION (Continued)

● SOT-89

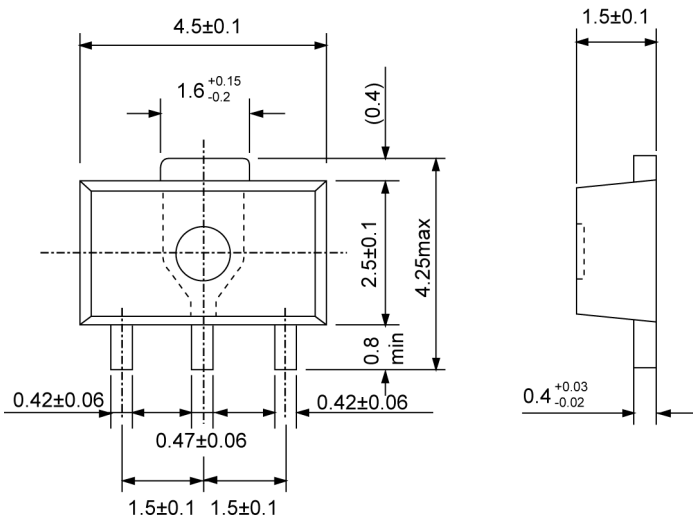

● TO-92

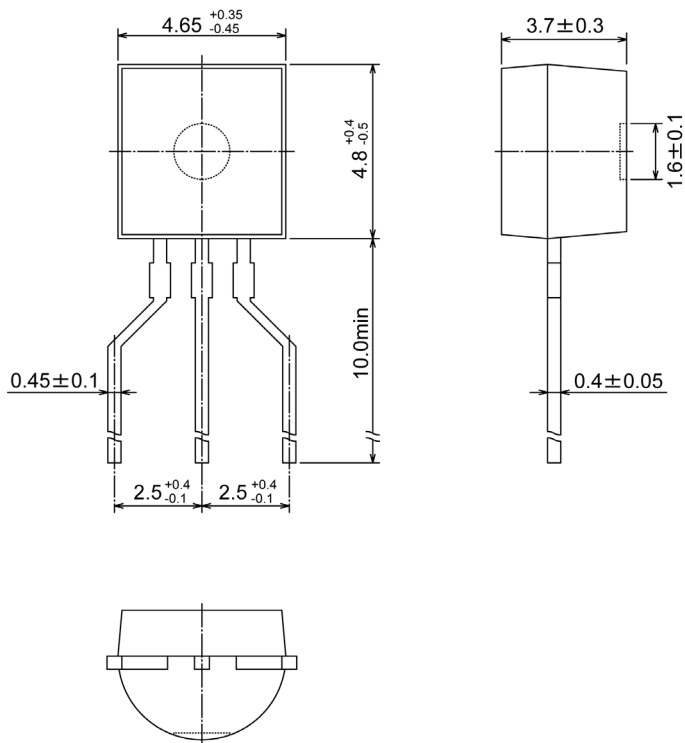

■ **PACKAGING INFORMATION (Continued)**

● **USP-6C**

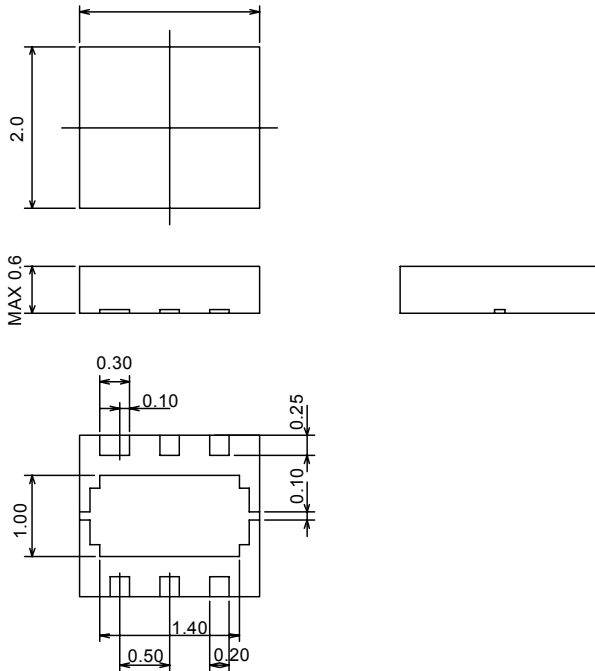

* Pin #1 is thicker than other pins.

● **USP-4**

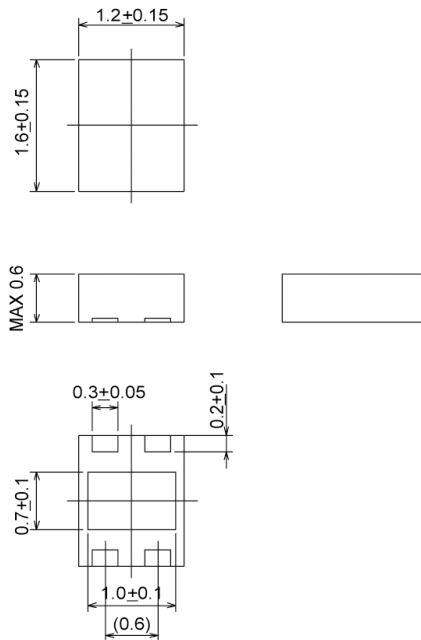

* Soldering fillet surface is not formed because the sides of the pins are plated.

MARKING RULE

● SSOT-24, SOT-23, SOT-89, USP-4

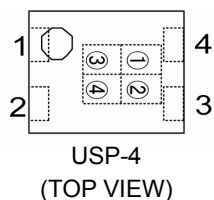
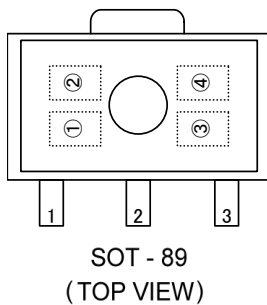
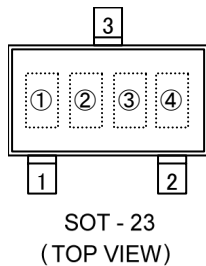
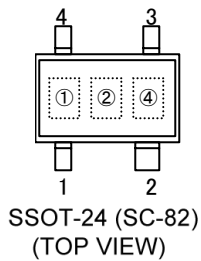

① Represents integer of output voltage and detect voltage
CMOS Output (XC61CC series)

MARK	CONFIGURATION	VOLTAGE (V)
A	CMOS	0.X
B	CMOS	1.X
C	CMOS	2.X
D	CMOS	3.X
E	CMOS	4.X
F	CMOS	5.X
G	CMOS	6.X

N-Channel Open Drain Output (XC61CN series)

MARK	CONFIGURATION	VOLTAGE (V)
K	N-ch	0.X
L	N-ch	1.X
M	N-ch	2.X
N	N-ch	3.X
P	N-ch	4.X
R	N-ch	5.X
S	N-ch	6.X

② Represents decimal number of detect voltage

MARK	VOLTAGE (V)	MARK	VOLTAGE (V)
0	X.0	5	X.5
1	X.1	6	X.6
2	X.2	7	X.7
3	X.3	8	X.8
4	X.4	9	X.9

③ Based on internal standard
(except for SSOT-24)

MARK
3

④ Represents production lot number
0 to 9, A to Z repeated. (G, I, J, O, Q, W excepted)

MARKING RULE (Continued)

TO-92

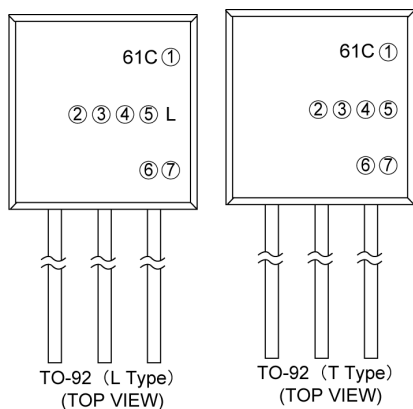

① Represents output configuration

MARK	OUTPUT CONFIGURATION
C	CMOS
N	N-ch

②, ③ Represents detect voltage

MARK		VOLTAGE (V)
②	③	
0	9	0.9
1	5	1.5

④ Represents delay time

MARK	DELAY TIME
0	No delay

⑤ Represents detect voltage accuracy

MARK	DETECT VOLTAGE ACCURACY
2	Within $\pm 2\%$

⑥ Represents a least significant digit of production year

MARK	PRODUCTION YEAR
3	2003
4	2004

⑦ Represents production lot number

0 to 9, A to Z repeated. (G, I, J, O, Q, W excepted)

USP-6C

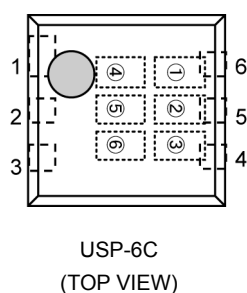

①, ② Represents product series

MARK		PRODUCT SERIES
①	②	
1	C	XC61Cxx0xDx

③ Represents output configuration

MARK	OUTPUT CONFIGURATION	PRODUCT SERIES
C	CMOS	XC61CCxx0xDx
N	N-ch	XC61CNxx0xDx

④, ⑤ Represents detect voltage

(example)

MARK		VOLTAGE (V)	PRODUCT SERIES
④	⑤		
3	3	3.3	XC61Cx330xDx
5	0	5.0	XC61Cx500xDx

⑥ Represents production lot number

0 to 9, A to Z repeated (G, I, J, O, Q, W excepted)

Note: No character inversion used.

■ BLOCK DIAGRAMS

(1) CMOS Output

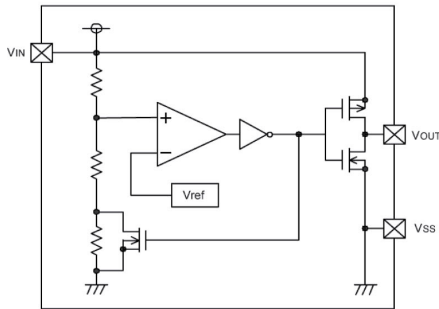

(2) N-ch Open Drain Output

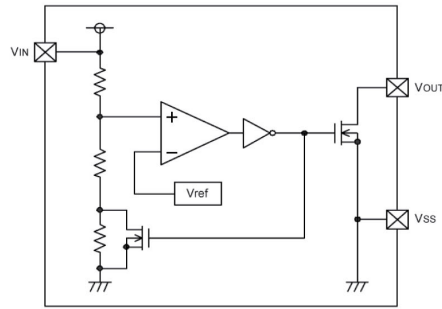

■ ABSOLUTE MAXIMUM RATINGS

Ta = 25°C

PARAMETER		SYMBOL	RATINGS	UNITS
Input Voltage	*1	VIN	9.0	V
	*2		12.0	
Output Current	*1	IOUT	50	mA
	*2		50	
Output Voltage	CMOS	VOUT	VSS - 0.3 ~ VIN + 0.3	V
	N-ch Open Drain Output *1		VSS - 0.3 ~ 9.0	
	N-ch Open Drain Output *2		VSS - 0.3 ~ 12.0	
Power Dissipation	SSOT-24	Pd	150	mW
	SOT-23		150	
	SOT-89		500	
	TO-92		300	
	USP-6C		100	
	USP-4		140**	
Operating Temperature Range		Topr	-40 ~ +85	°C
Storage Temperature Range		Tstg	-40 ~ +125	°C

*1: Low voltage

*2: Standard voltage

**When mounted on glass epoxy.

■ ELECTRICAL CHARACTERISTICS

 $V_{DF(T)} = 0.9 \text{ to } 1.5V \pm 2\%$
 $T_a = 25^\circ\text{C}$

PARAMETER	SYMBOL	CONDITIONS	MIN.	TYP.	MAX.	UNITS	CIRCUITS	
Detect Voltage	V_{DF}		$V_{DF} \times 0.98$	V_{DF}	$V_{DF} \times 1.02$	V	1	
Hysteresis Range	V_{HYS}		$V_{DF} \times 0.02$	$V_{DF} \times 0.05$	$V_{DF} \times 0.08$	V	1	
Supply Current	I_{SS}	$V_{IN} = 1.5V$	-	0.7	2.3	μA	2	
		$V_{IN} = 2.0V$	-	0.8	2.7			
		$V_{IN} = 3.0V$	-	0.9	3.0			
		$V_{IN} = 4.0V$	-	1.0	3.2			
		$V_{IN} = 5.0V$	-	1.1	3.6			
Operating Voltage	V_{IN}	Low Voltage: $V_{DF(T)} = 0.8V \text{ to } 1.5V$	0.7	-	6.0	V	1	
		Standard Voltage: $V_{DF(T)} = 1.6V \text{ to } 6.0V$	0.7	-	10.0			
Output Current (Low Voltage)	I_{OUT}	N-ch $V_{DS} = 0.5V$	$V_{IN} = 0.7V$	0.10	0.80	-	mA	3
			$V_{IN} = 1.0V$	0.85	2.70	-		4
Output Current (Standard Voltage)	I_{OUT}	CMOS, P-ch $V_{DS} = 2.1V$	$V_{IN} = 6.0V$	-	-7.5	-1.5	mA	4
			N-ch $V_{DS} = 0.5V$	$V_{IN} = 1.0V$	1.0	2.2		-
		$V_{IN} = 2.0V$		3.0	7.7	-		
		$V_{IN} = 3.0V$		5.0	10.1	-		
		$V_{IN} = 4.0V$		6.0	11.5	-		
		$V_{IN} = 5.0V$	7.0	13.0	-			
CMOS, P-ch $V_{DS} = 2.1V$	$V_{IN} = 8.0V$	-	-10.0	-2.0	4			
Temperature Characteristics	$\frac{\Delta V_{DF}}{\Delta T_{opr} \cdot V_{DF}}$	$-40^\circ\text{C} \leq T_{opr} \leq 85^\circ\text{C}$	-	± 100	-	ppm/ $^\circ\text{C}$	-	
Delay Time ($V_{DR} \rightarrow V_{OUT}$ inversion)	t_{DLY}		-	0.03	0.2	ms	5	

NOTE:

 $V_{DF(T)}$: Setting detect voltage

 Release Voltage: $V_{DR} = V_{DF} + V_{HYS}$

OPERATIONAL EXPLANATION

CMOS output

- ① When input voltage (V_{IN}) rises above detect voltage (V_{DF}), output voltage (V_{OUT}) will be equal to V_{IN} .
(A condition of high impedance exists with N-ch open drain output configurations.)
- ② When input voltage (V_{IN}) falls below detect voltage (V_{DF}), output voltage (V_{OUT}) will be equal to the ground voltage (V_{SS}) level.
- ③ When input voltage (V_{IN}) falls to a level below that of the minimum operating voltage (V_{MIN}), output will become unstable. In this condition, V_{IN} will equal the pulled-up output (should output be pulled-up.)
- ④ When input voltage (V_{IN}) rises above the ground voltage (V_{SS}) level, output will be unstable at levels below the minimum operating voltage (V_{MIN}). Between the V_{MIN} and detect release voltage (V_{DR}) levels, the ground voltage (V_{SS}) level will be maintained.
- ⑤ When input voltage (V_{IN}) rises above detect release voltage (V_{DR}), output voltage (V_{OUT}) will be equal to V_{IN} .
(A condition of high impedance exists with N-ch open drain output configurations.)
- ⑥ The difference between V_{DR} and V_{DF} represents the hysteresis range.

Timing Chart

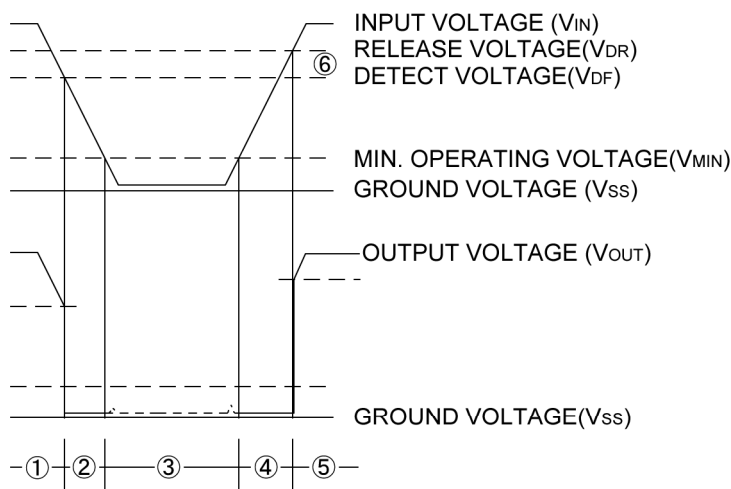

■ NOTES ON USE

1. Please use this IC within the stated maximum ratings. Operation beyond these limits may cause degrading or permanent damage to the device.
2. When a resistor is connected between the V_{IN} pin and the input with CMOS output configurations, oscillation may occur as a result of voltage drops at R_{IN} if load current (I_{OUT}) exists. (refer to the Oscillation Description (1) below)
3. When a resistor is connected between the V_{IN} pin and the input with CMOS output configurations, irrespective of N-ch output configurations, oscillation may occur as a result of through current at the time of voltage release even if load current (I_{OUT}) does not exist. (refer to the Oscillation Description (2) below)
4. With a resistor connected between the V_{IN} pin and the input, detect and release voltage will rise as a result of the IC's supply current flowing through the V_{IN} pin.
5. In order to stabilize the IC's operations, please ensure that V_{IN} pin's input frequency's rise and fall times are more than several μ sec / V.
6. Please use N-ch open drains configuration, when a resistor R_{IN} is connected between the V_{IN} pin and power source. In such cases, please ensure that R_{IN} is less than $10k\Omega$ and that C is more than $0.1\mu F$.

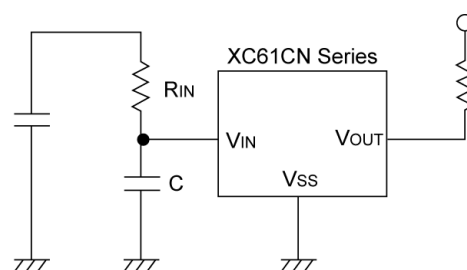

Figure 1: Circuit using an input resistor

● Oscillation Description

(1) Output current oscillation with the CMOS output configuration

When the voltage applied at IN rises, release operations commence and the detector's output voltage increases. Load current (I_{OUT}) will flow at R_L . Because a voltage drop ($R_{IN} \times I_{OUT}$) is produced at the R_{IN} resistor, located between the input (IN) and the V_{IN} pin, the load current will flow via the IC's V_{IN} pin. The voltage drop will also lead to a fall in the voltage level at the V_{IN} pin. When the V_{IN} pin voltage level falls below the detect voltage level, detect operations will commence. Following detect operations, load current flow will cease and since voltage drop at R_{IN} will disappear, the voltage level at the V_{IN} pin will rise and release operations will begin over again.

Oscillation may occur with this " release - detect - release " repetition.

Further, this condition will also appear via means of a similar mechanism during detect operations.

(2) Oscillation as a result of through current

Since the XC61C series are CMOS IC s, through current will flow when the IC's internal circuit switching operates (during release and detect operations). Consequently, oscillation is liable to occur as a result of drops in voltage at the through current's resistor (R_{IN}) during release voltage operations. (refer to Figure 3)

Since hysteresis exists during detect operations, oscillation is unlikely to occur.

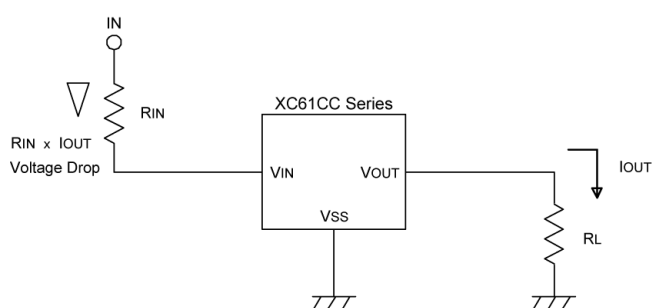

Figure 2: Oscillation in relation to output current

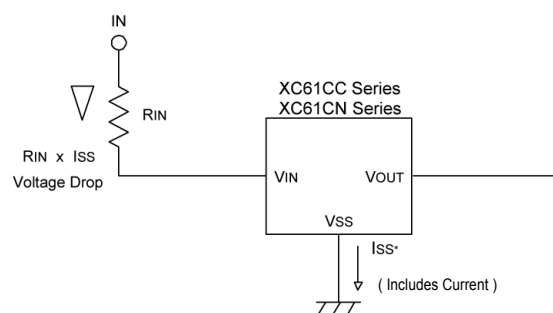
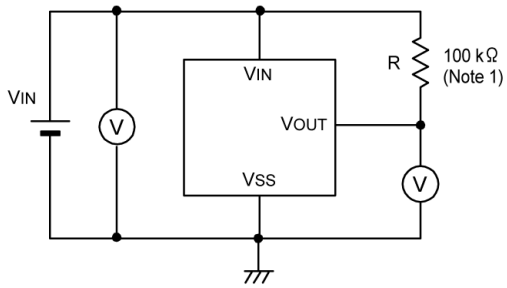

Figure 3: Oscillation in relation to through current

TEST CIRCUITS

Circuit 1



Circuit 2

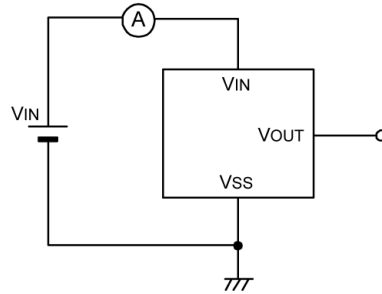

Circuit 3

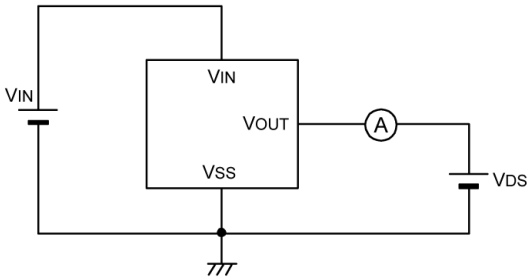

Circuit 4

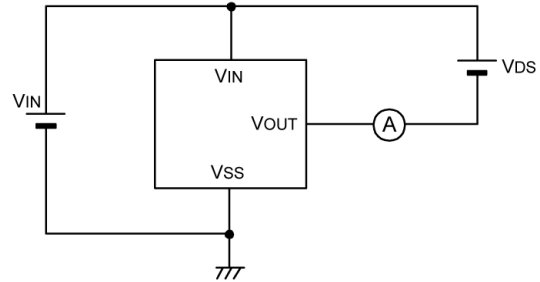

Circuit 5

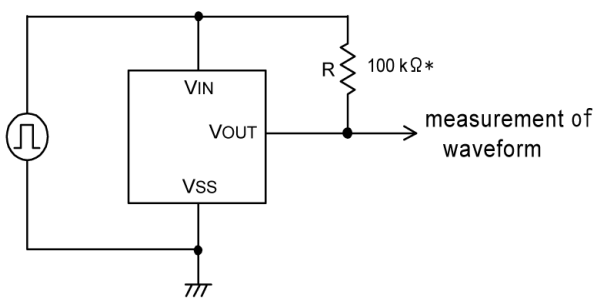

* : A resistor is not necessary with CMOS output products.

■ TYPICAL PERFORMANCE CHARACTERISTICS

● Low Voltage

(1) Supply Current vs. Input Voltage

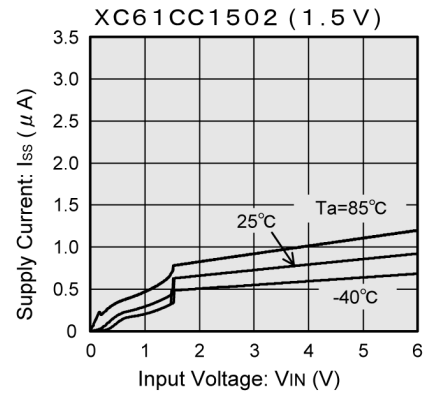
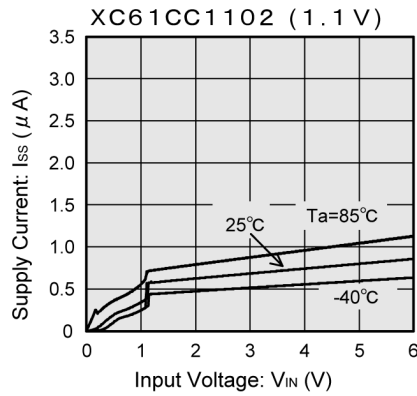
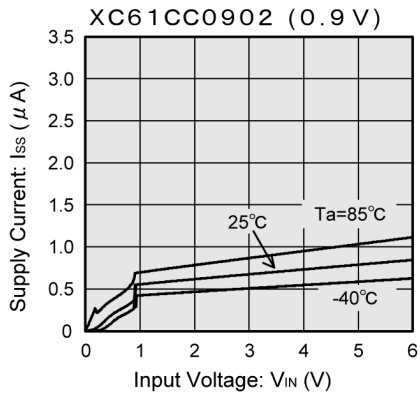

(2) Detect, Release Voltage vs. Ambient Temperature

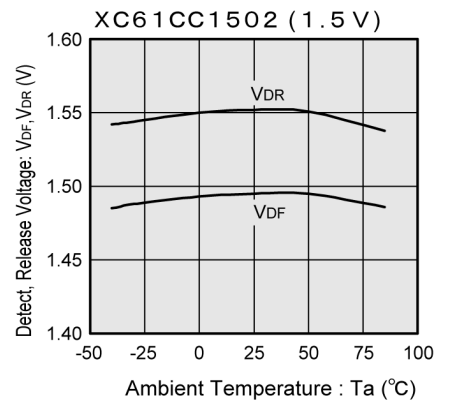
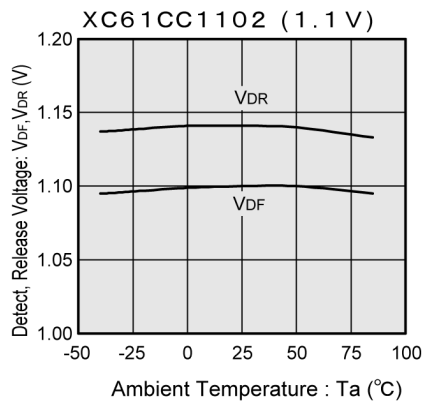
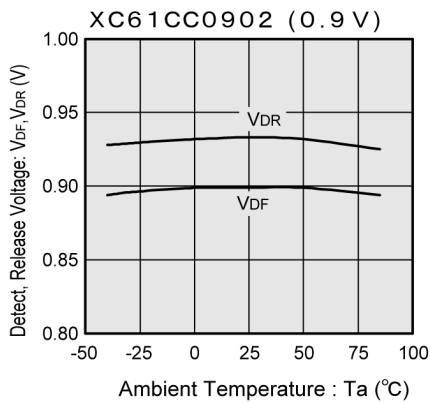

(3) Output Voltage vs. Input Voltage

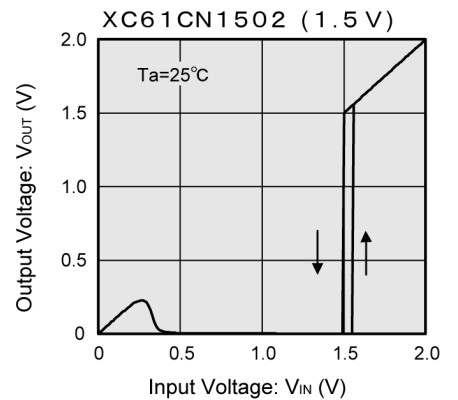
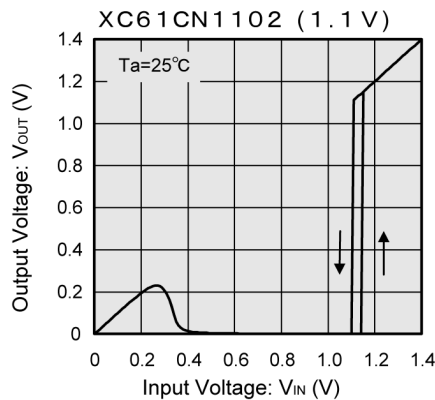
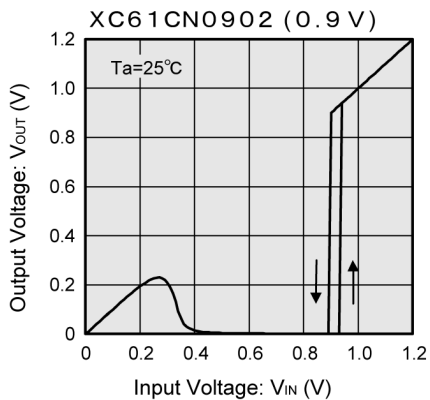

Note : Unless otherwise stated, the N-channel open drain pull-up resistance value is 100kΩ.

■ TYPICAL PERFORMANCE CHARACTERISTICS (Continued)

● Low Voltage (Continued)

(4) N-ch Driver Output Current vs. V_{DS}

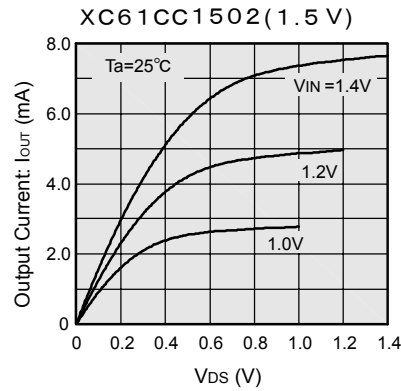
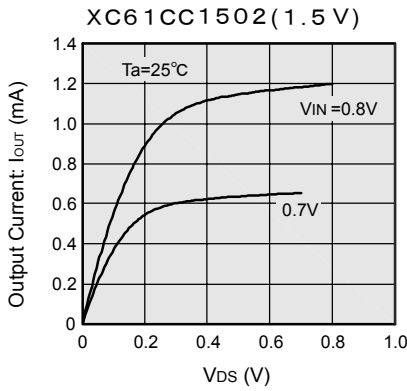
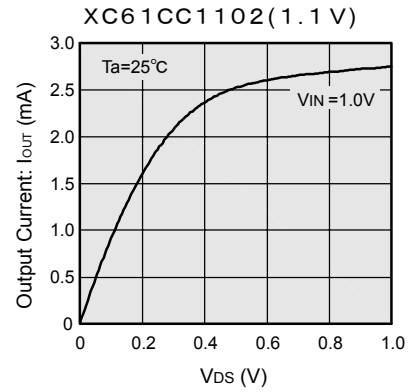
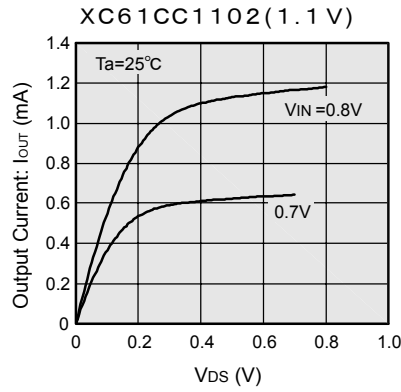
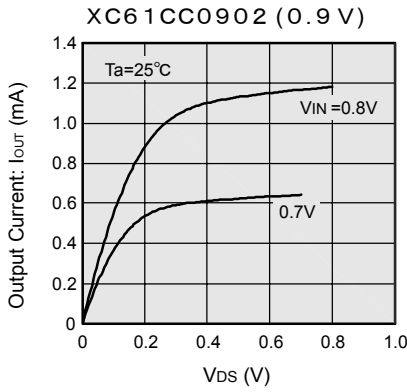

(5) N-ch Driver Output Current vs. Input Voltage

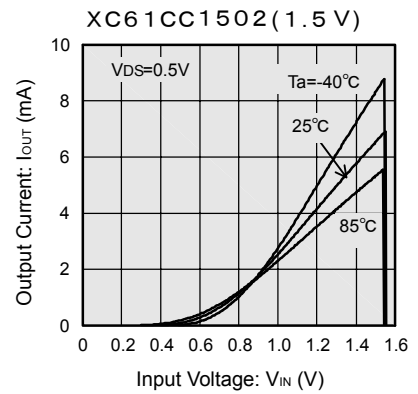
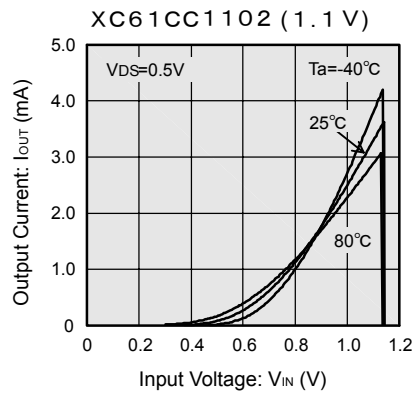
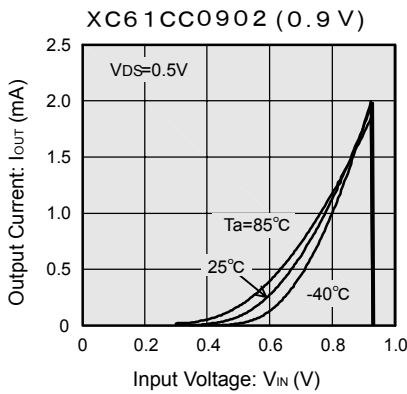

(6) P-ch Driver Output Current vs. Input Voltage

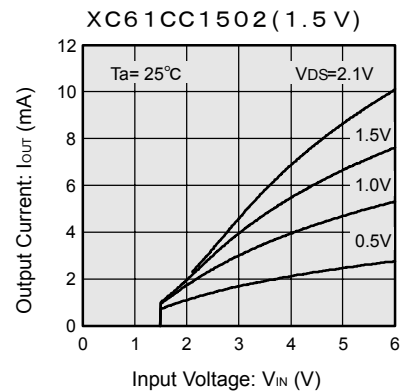
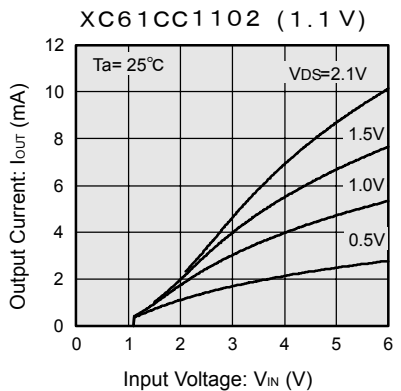
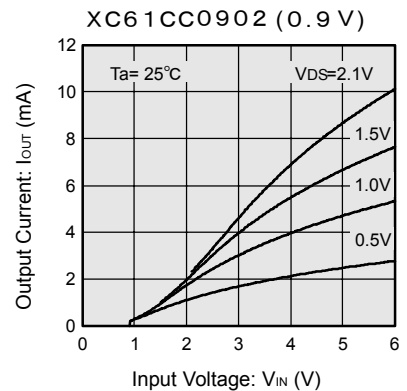

■ TYPICAL PERFORMANCE CHARACTERISTICS (Continued)

● Standard Voltage

(1) Supply Current vs. Input Voltage

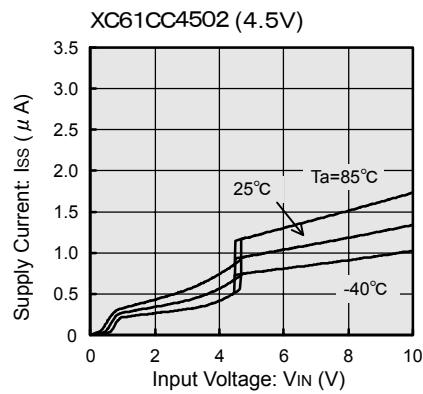
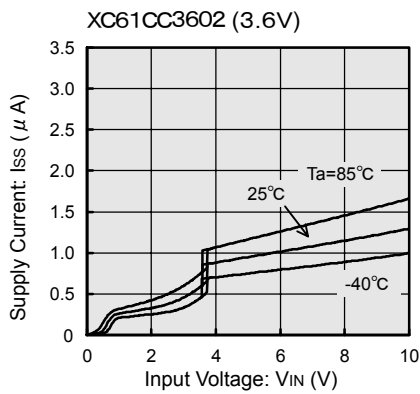
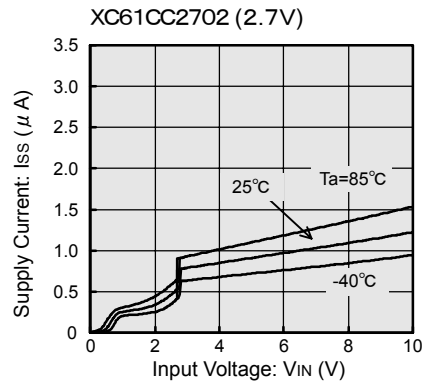
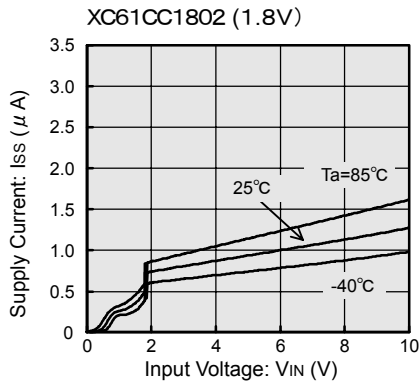

(2) Detect, Release Voltage vs. Ambient Temperature

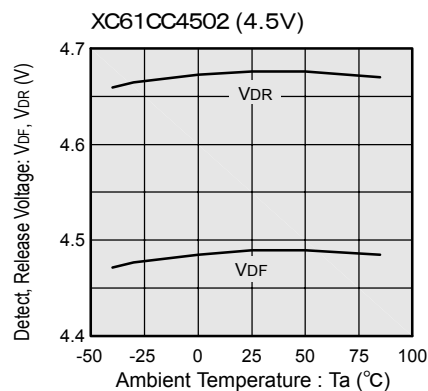
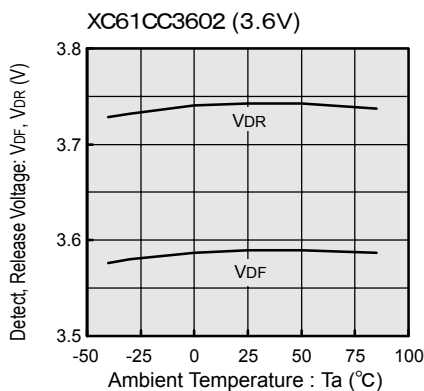
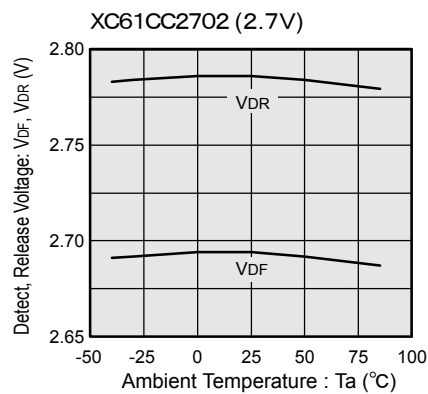
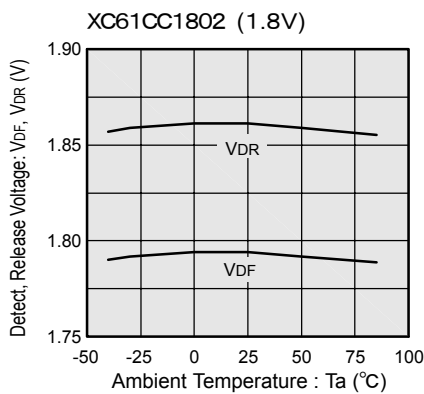

■ TYPICAL PERFORMANCE CHARACTERISTICS (Continued)

● Standard Voltage (Continued)

(3) Output Voltage vs. Input Voltage

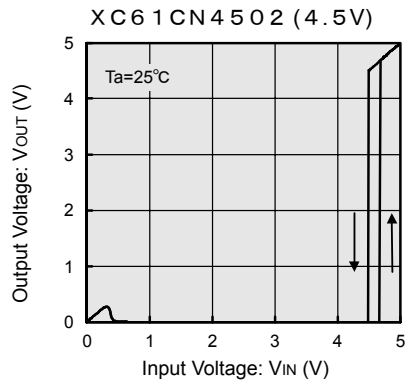
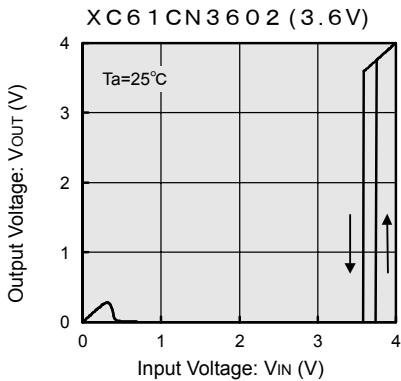
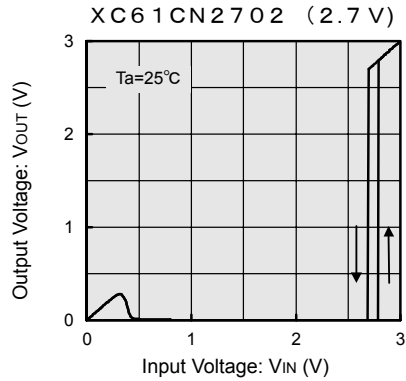
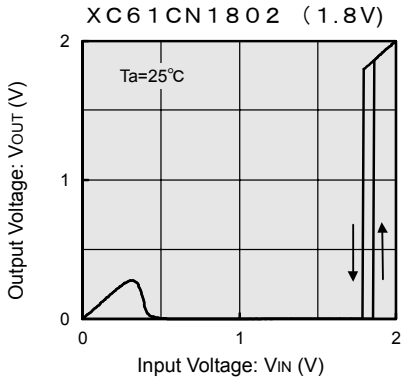

Note : The N-channel open drain pull up resistance value is $100\text{k}\Omega$.

(4) N-ch Driver Output Current vs. V_{DS}

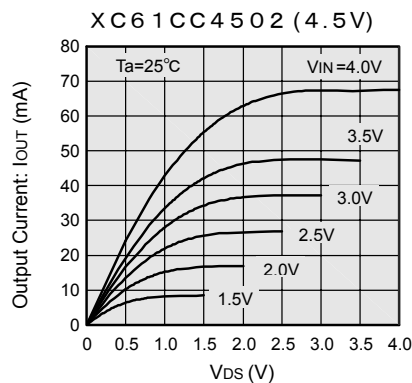
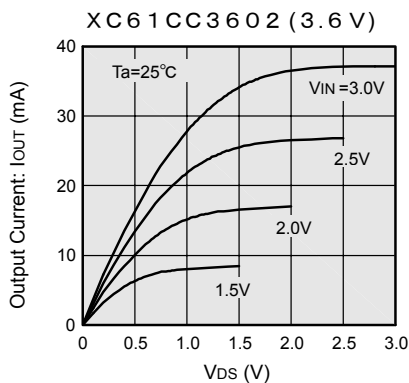
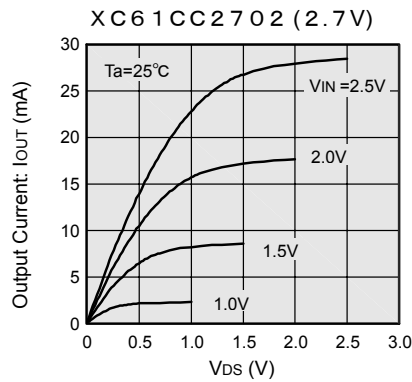
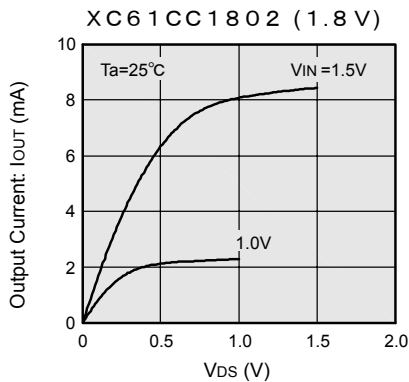

■ TYPICAL PERFORMANCE CHARACTERISTICS (Continued)

● Standard Voltage (Continued)

(4) N-ch Driver Output Current vs. V_{DS}

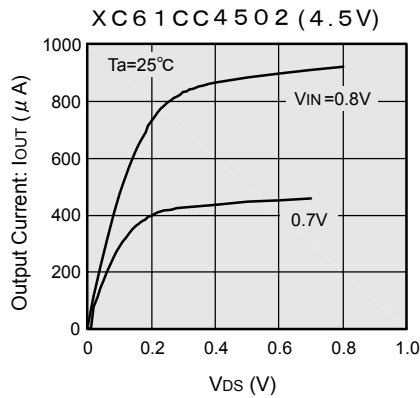
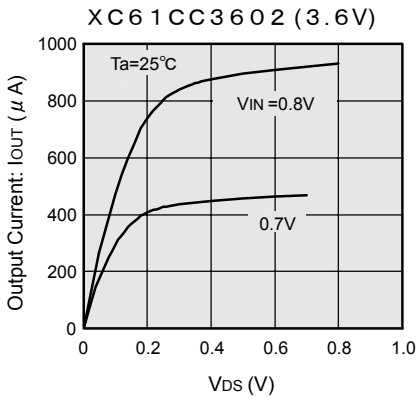
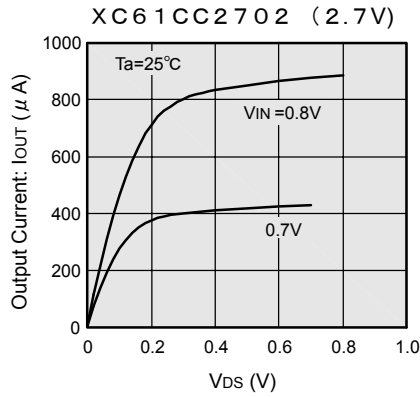
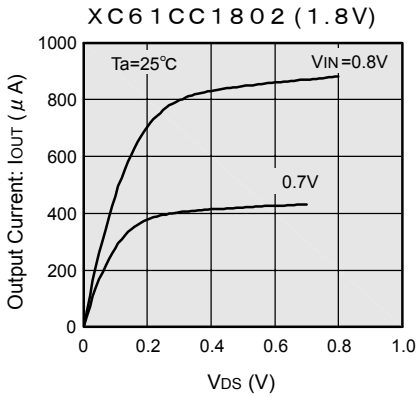

(5) N-ch Driver Output Current vs. Input Voltage

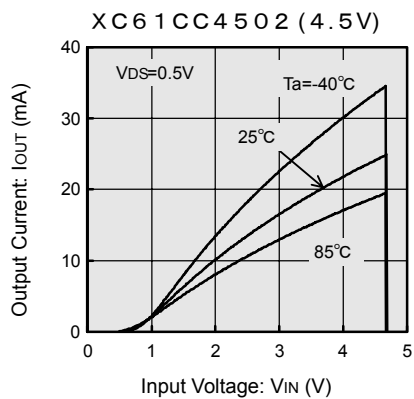
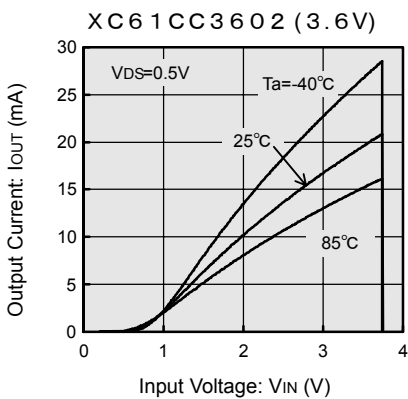
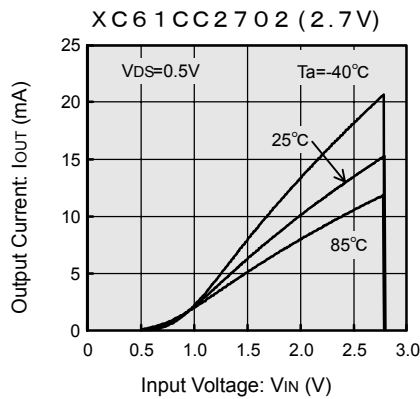
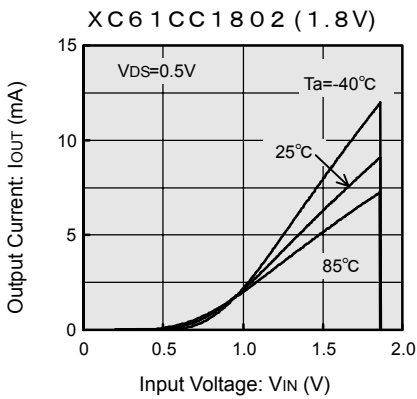

■ TYPICAL PERFORMANCE CHARACTERISTICS (Continued)

● Standard Voltage (Continued)

(6) P-ch Driver Output Current vs. Input Voltage

