



## Technical Specification

### DMPR MK4 Electronic Motor Protection Relay

The DMPR, together with suitable current transformers, monitors motor supply current. Three-phase motors generally require two CTs. An overload condition causes the unit to trip after a time delay inversely proportional to the overcurrent.

The DMPR uniquely provides independently adjustable time delays for starting and normal running. This allows an extended response time during starting, minimising nuisance trips, while maintaining a fast response during normal running. By setting the run delay at minimum (0,2s), shearpin type protection is achieved. Automatic transfer from the start delay to run delay occurs after a period of approximately twice the selected start delay. If necessary the start delay can be disabled to give conventional single delay operation.

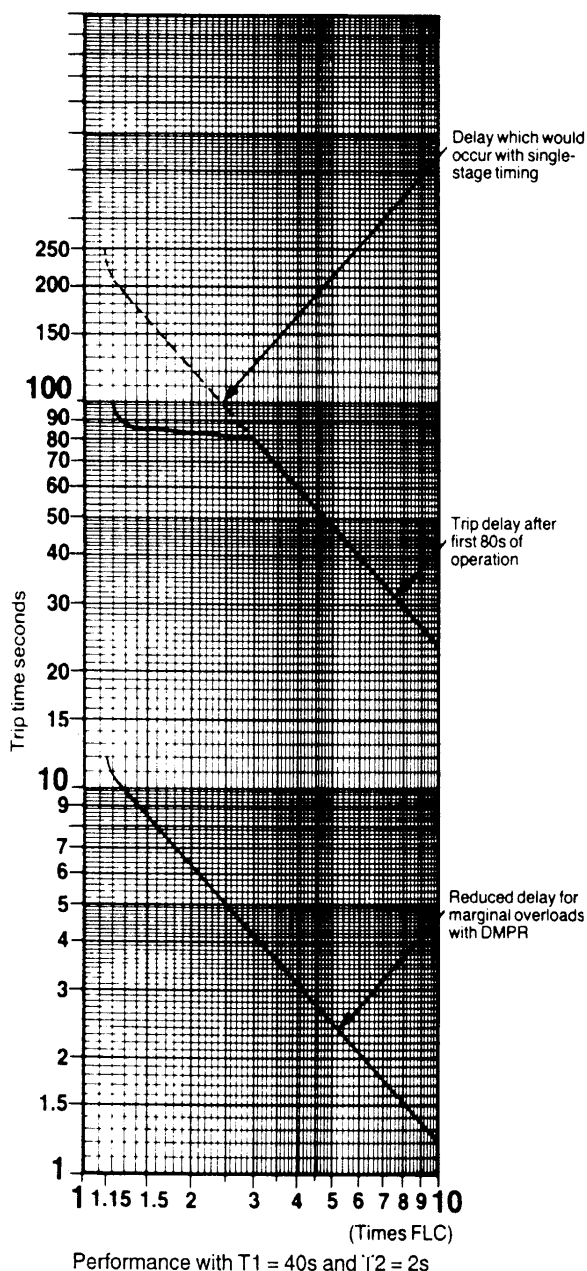

Auto/manual reset facilities, with an adjustable reset delay, are provided. A pushbutton is fitted for local reset, with terminals for a remote reset contact.

A latching version is also available, which contains a retentive circuit which is not affected by loss of supply; if supply is removed following a trip condition, the trip status (in the manual reset mode) is remembered when the supply is restored. The unit can be reset in the manual mode only by momentarily linking terminals R1 and R2 - or operating the RESET button - with supply connected. Other DMPR features include phase loss detection, motor temperature monitoring and a test button to confirm unit operation.

#### Technical specification

Supply voltage: (Must be specified)	110...120/220...240V or 380...415V : 50/60Hz 3VA
Load current range:	Up to 200A using a single CT in each of two phases, extending to 3000A with 2 CTs per phase. See CT selection charts. The current range at the DMPR input is 17,5 - 50mA.
Output relay:	Ratings (n.c. and n.o. contacts) Resistive load: 5A at 240V    2A at 415V
A.C. inductive load switching (B600) I <sub>o</sub> = 5A max.	120V to 415V max. Make: 3600VA    Break: 360VA
D.C. inductive load switching (Q300) I <sub>o</sub> = 2,5mA	125V & 250V Make: 69W    Break: 69W
Ambient temperature range	-10° C to +60° C
Operations/h:	60 max.
Indicators:	Green- Power On. Amber- Trip level exceeded / timing in progress Amber- Output relay de-energised
Phase imbalance:	Normal time-delayed tripping if any line current exceeds set trip level
Phase loss:	Trip within 2s provided load current exceeds 50% of set trip level. Disabled by linking terminals S1 + S2 when used with soft starters or single-phase motors.
Start Delay T1:	4-40s at 600% FLC Enabled by linking terminals S2 + S3
Run Delay T2:	0,2 - 8s at 600% FLC See Time/current graph
Motor temperature:	Trip when sensing element exceeds 2-4KΩ, reset when resistance falls to 750Ω. Suitable for motor thermistors to BS4999 Part 111. Alternatively a normally-closed bi-metallic thermostat can be used. Disabled by linking terminals P1 and P2.
Reset:	Hand/Auto selection by terminal link. Button for local reset, terminals for remote reset, contact loading 2mA at 20V d.c. Reset delay (hand or auto) 1-20m
Caution:	If supply is removed for a period greater than 200ms the reset delay is terminated, and non-latching versions reset automatically when supply is restored. Manual reset should be used for latching versions.
Test:	Test button simulates 600% FLC overload to check operation
Enclosure:	IP20 EN35 top hat rail or surface mounting
Terminal cable capacity:	1 x 2,5mm <sup>2</sup>

#### Order references

<b>DMPR Standard</b>	
115/230V	<b>DMPR 230S 000</b>
400V	<b>DMPR 400S 000</b>

<b>DMPR Latching</b>	
115/230V	<b>DMPR 230L 000</b>
400V	<b>DMPR 400L 000</b>

Current transformers	Type
20A : 25mA	01 000158 221 CTA
50A : 25mA	222 CTA
100A : 25mA	223 CTA
500A : 5A	300 CTB
1000A : 5A	302 CTB
2000A : 5A	303 CTB
3000A : 5A	304 CTB

# Technical Specification

## Terminal functions

A1. Supply	R1. } Remote reset
A2. 115/230V or 400V	R2. } Volt-free n.o. contact required
A3. dependent on model	(Link for auto reset)
95. } Trip contact (Closed	P1. } Thermistor trip
96. } when relay is energised)	P2. } Link to disable
05. common	C. CT common
06. n.o. (Closed when relay is energised)	C1. CT1
	C2. CT2
08. n.c. (Open when relay is energised)	S1. } Phase loss - disabled by link to S2
	S2. } Function common
	S3. } Start delay T1 - enabled by link to S2

Alarm contact

## Time/current graph

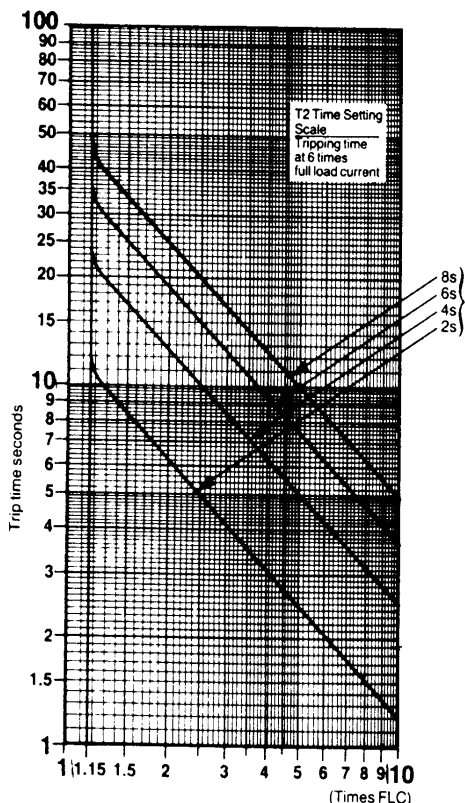

Typical operating time characteristics during running

## Setting up procedure

### Method 1:

Set FLC and time delay potentiometers to required values. The trip current will be in the range 105-120% of set FLC.

### Method 2:

For precise setting with close protection.

1. With the current and both trip delays set to maximum, start the motor.
2. Reduce current setting until amber SET LED is illuminated, then increase setting until LED is just extinguished. The unit is then correctly set.
3. When the current increases by 10-15% the amber SET LED will illuminate and the unit will go into overload mode.
4. Trip delay settings and Reset time should be set to suitable values. A suitable value for T1 delay should be sufficient to allow motor to run up to speed on maximum load. The higher the load inertia the longer the trip delay required.
5. For motors with short acceleration times, T1 may not be required, in which case the T1 link should be omitted.
6. T2 setting can be adjusted to give a faster trip response during running whilst allowing for normal fluctuations in current which might cause nuisance tripping.

### Method 3 :

Inject test current corresponding to load current directly into DMPR (allowing for CT turns ratio) and follow method 2.

The current range at the input terminals of the DMPR is 17,5 - 50mA. Single-phase injection (using one CT or directly into terminals C + C1) requires a current 40% higher than corresponding 3-phase.

## Current transformer selection table

FLC adjustment span (A)	CTA reference	Primary turns	CTB (One primary turn)
0,7 - 2	RS346 - 261*	-	-
1,4 - 4	01 / 000158 / 221	10	-
1,75 - 5	01 / 000158 / 221	8	-
3,5 - 10	01 / 000158 / 221	4	-
7 - 20	01 / 000158 / 221	2	-
14 - 40	01 / 000158 / 221	1	-
17,5 - 50	01 / 000158 / 222	2	-
35 - 100	01 / 000158 / 222	1	-
70 - 200	01 / 000158 / 223	1	-
175 - 500	01 / 000158 / 221	8	01 / 000158 / 300
350 - 1000	01 / 000158 / 221	8	01 / 000158 / 302
700 - 2000	01 / 000158 / 221	8	01 / 000158 / 303
1050 - 3000	01 / 000158 / 221	8	01 / 000158 / 304

\* Order wound primary current transformers direct from RS Components Limited.

# Technical Specification

## Typical wiring diagrams

**DOL starter, 415V coil, 3-phase 3-wire supply**  
Up to 200A using directly connected CTs

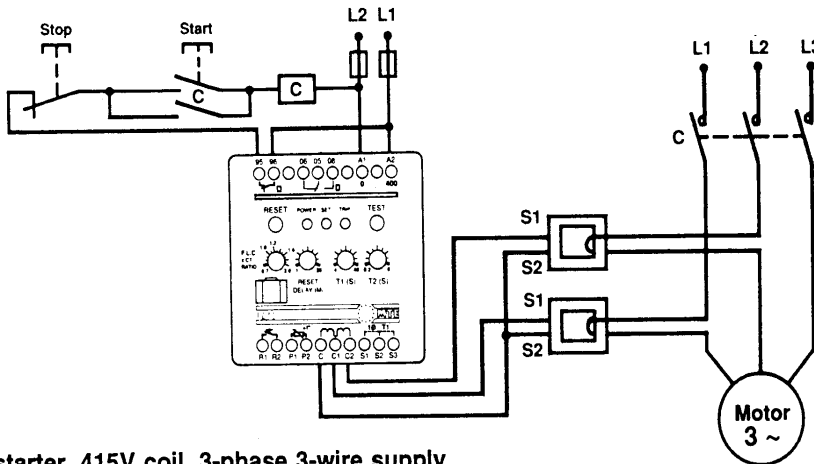

**DOL starter, 415V coil, 3-phase 3-wire supply**  
Up to 3000A using cascaded CTs

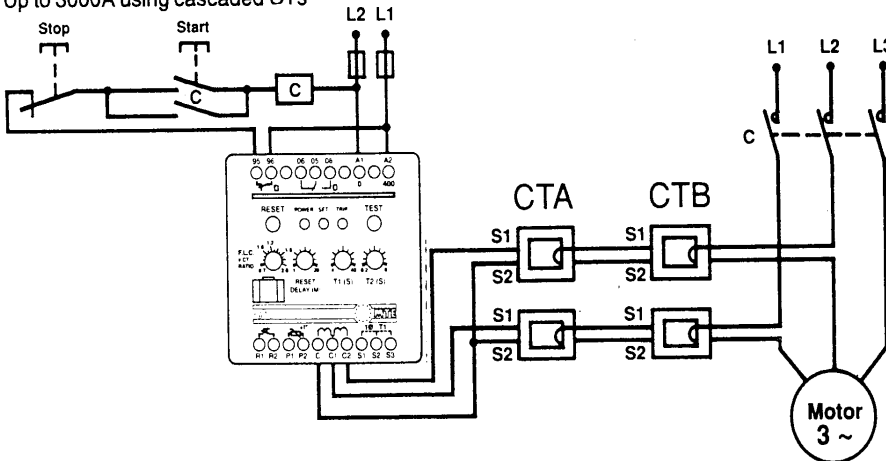

**DOL starter 240V coil, 3-phase 4-wire supply**

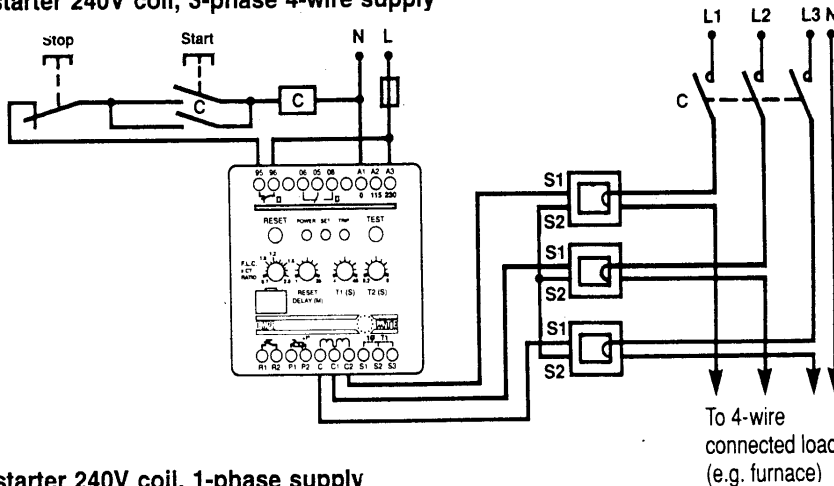

**DOL starter 240V coil, 1-phase supply**

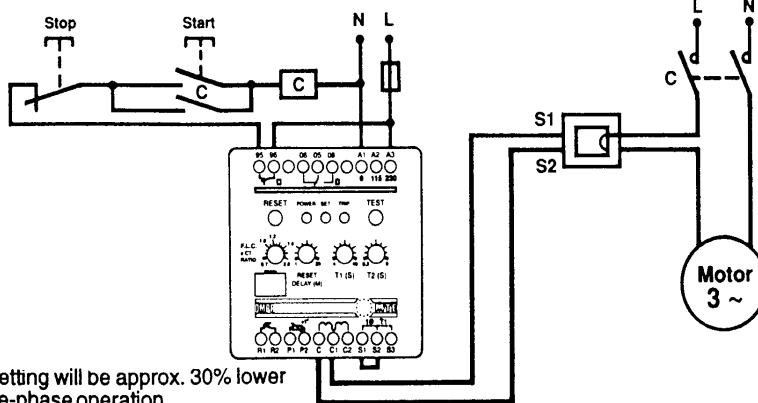

**Note:** Trip setting will be approx. 30% lower than for three-phase operation

**Operation:** When power is applied to the DMPR, the output relay energises, closing contacts 95 - 96 and 05 - 06. If the motor current exceeds the set level and the associated delay time the relay de-energises, disabling the starter circuit.

**Installation:** Terminals R1 to S3 inclusive (i.e all lower terminals) are internally connected to a common circuit. P1 terminal only may be earthed. Wiring to all other terminals must be isolated and adequately insulated.  
To avoid inductive pickup, thermistor wiring should be twisted pair and/or screened cable. This cable should not be run parallel to other cabling for long distances as a protection against capacitive pickup.  
4A HBC fuses are recommended for control circuit protection, connected as shown.

# Technical Specification

## Dimensions (mm)

DMPR

Weight 0,35kg

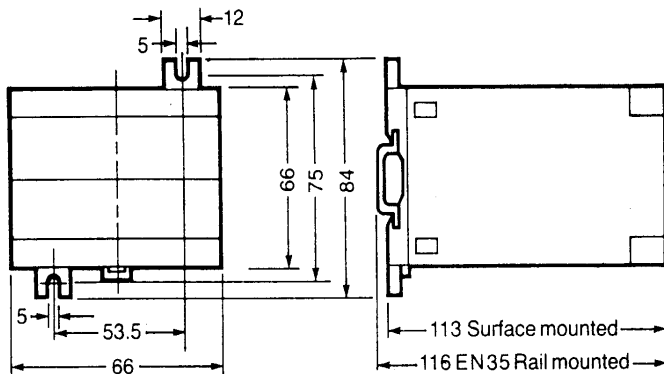

DIN enclosure

Order references

01 000158 221  
01 000158 222  
01 000158 223

Weight 0,24kg

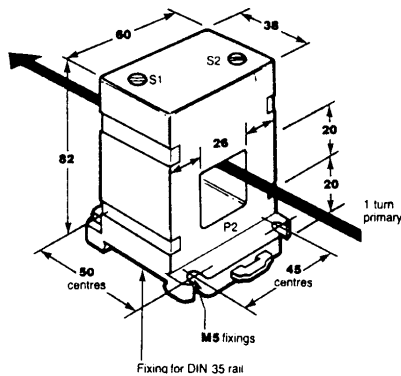

Order references

01 000158 300

Weight 1kg

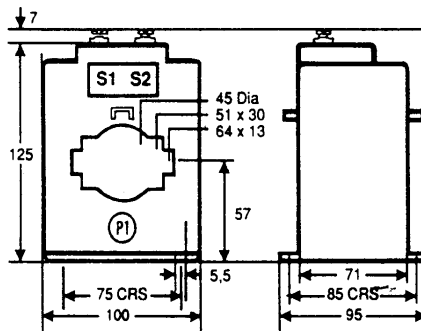

Order references

01 000158 302  
01 000158 303  
01 000158 304

Weight 2kg

