

1

2

3

4

5

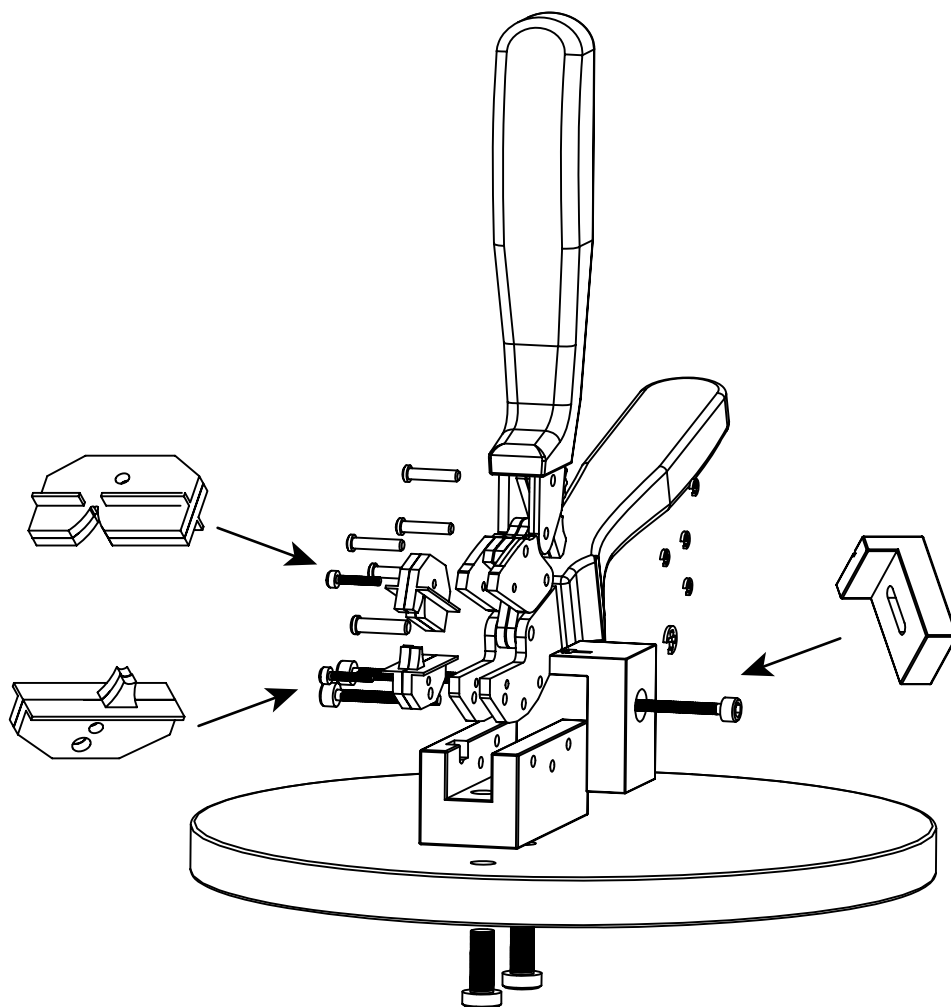

CHARACTERISTICS

- TOOL FOR WIRE ASSEMBLY WITH CRIMPING TERMINAL
- DESIGNED FOR HAND USE
- EASY PROCESS - DO NOT REQUIRE STRONG PRESSURE
- CRIMPING QUALITY SIMILAR TO AUTOMATIC MOUNTING

INSTRUCTIONS FOR USE:

- INTRODUCE THE TERMINAL INTO DIE'S CAVITY
- PUT CORRECTLY THE WIRE INTO THE TERMINAL
- PRESS THE HANDLE
- REMOVE THE CRIMPED WIRE

RoHS Compliant

PROJECTION:

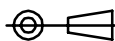

GENERAL TOLERANCE

.X = +/- 0.2

.XX = +/- 0.15



APPROVAL: RJ

UNIT: MM

DESCRIPTION: MPC4 HAND PLIER FOR FEMALE CRIMP TERMINAL
(64900113722) WIRE 22-16 AWG (0.33 TO 1.31MM²)

SIZE

SCALE:

SHEET: 1/1

WERI PART NO: 600649222161

A4

APPROVAL: RJ

DRAW: CH

G			
F			
E			
D			
C			
B	23-DEC-07	DESCRIPTION	EC
A	24-APR-07	PDF	JPP
REV	DATE	FILE	BY