

308 225

technical manual

impact dot matrix printer

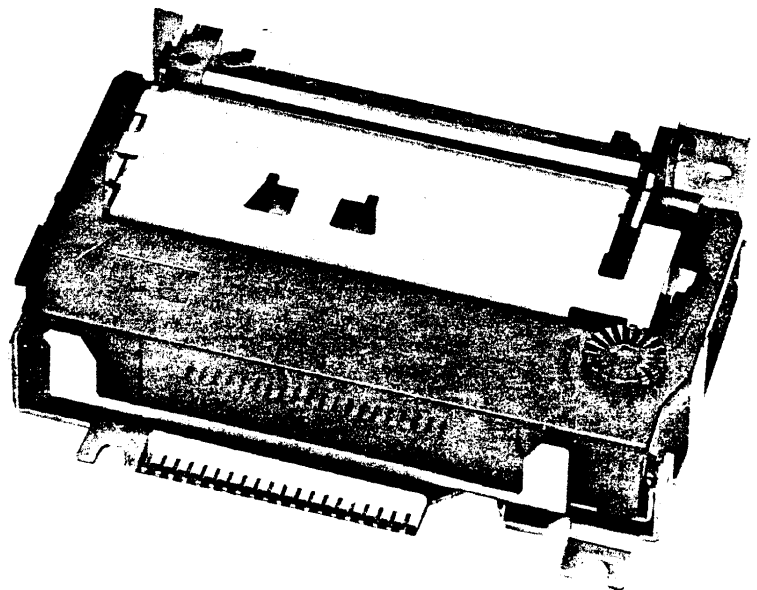

English

PREFACE

This Technical Manual for this printer contains a description of the mechanisms and instructions on maintenance and repair of the printer.

Major technical modifications or improvements of the printer, if made in future, will be published in SERVICE BULLETINS, which can be used in conjunction with this Manual. The contents of this Manual are subject to change without prior notice.

Should any discrepancy exist between the contents of this Technical Manual and the provisions of "Master Contract" or the Specifications, the latter shall take precedence over the former.

We shall not be responsible for any troubles that might occur from the customer's applying this Manual to machines other than this printer or his applying to said printer a drive circuit or other device which is a third party's industrial property.

If you desire to produce copies of the whole or part of this Manual for the purpose of distributing to a third parties, please notify us in advance.

TABLE OF CONTENTS

CHAPTER 1

SPECIFICATIONS AND OPERATING PRINCIPLES

CHAPTER 2

HANDLING, MAINTENANCE, AND REPAIR

CHAPTER 3

DISASSEMBLY, ASSEMBLY, AND ADJUSTMENT

CHAPTER 1

SPECIFICATIONS AND OPERATING PRINCIPLES

CONTENTS

1.1	SPECIFICATIONS.....	1- 1
1.1.1	Features.....	1- 1
1.1.2	Specifications.....	1- 1
1.1.3	Mechanisms.....	1- 3
1.2	OPERATING PRINCIPLES.....	1- 3
1.2.1	Transmission Mechanism.....	1- 3
1.2.2	Detection Mechanism.....	1- 4
1.2.3	Printing Mechanism.....	1- 5
1.2.4	Paper Feeding Mechanism.....	1- 6
1.2.5	Ribbon Feeding Mechanism.....	1- 8
1.2.6	Ribbon Switching Mechanism.....	1- 9
1.2.7	Printer Operation.....	1-11

1.1 SPECIFICATIONS

1.1.1 Features

The Model-260 and Model-262 Micro Dot Printer were developed and designed for use mainly as a hard copy device for a wide range of applications, such as for POS or ECR, the issuing of slips, general measuring instruments, and other kitchen printers. These two models offer the following features:

- Slim, compact, and lightweight design
- Extremely clear and well-defined printing quality
- Capable of graphics printing due to the adoption of a shuttle head
- Use of ordinary paper
- Capable of multi-form duplication printing (1 original sheet + 2 copies)
- Use of a dedicated long-life ribbon cassette
- Capable of two-color printing in black or red (Model-262 only)
- Use of the same trigger coil to control paper feeding and ribbon-color switching (Model-262 only)

1.1.2 Specifications

The main specifications are listed as follows. For further details, refer to our separate "Model-260/262 Specifications."

Print method : Mechanical dot printer (with built-in shuttle head)

Total no. of dots
: Max. 210 dots/1 dot line
(When using the normal dot positions plus the half-dot positions, 420 dots positions can be printed (see Fig. 1-2). For details, refer to the "Model-260/262 Specifications.")

Basic Printed Dot Positions (for 5×7 dot matrix)
(210 Dot Positions)

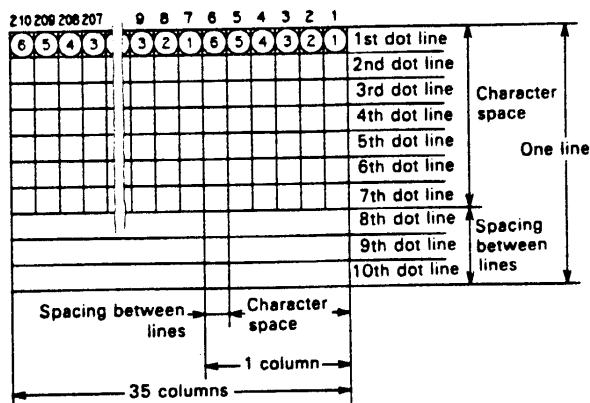

Fig. 1-1. Basic Printed Dot Positions

420 Dot Positions

- : Basic printed dot positions (1, 2, 3,...)
- : Half-printed dot positions (①, ②, ③,...)

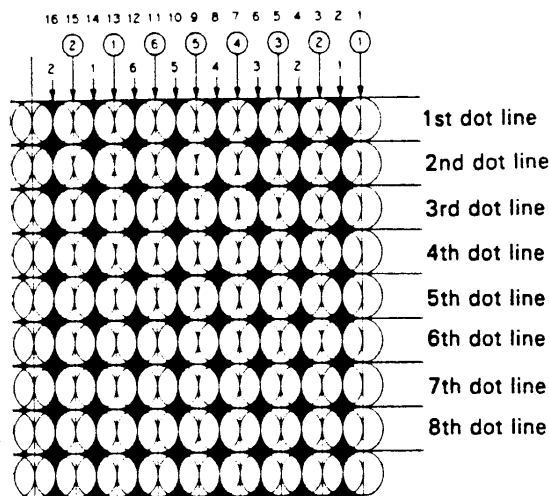

Fig. 1-2. 420 Printed Dot Positions

No. of printed columns

- ① Normal dot positions: Max. 35 columns (5×7 dot matrix with 1-dot column spacing)
- ② Combined normal and half dot positions: 42 columns (7×7 dot matrix with 1-dot column spacing)

Character format (width × height)

- ① Normal dot positions: 1.6 mm × 2.9 mm (5×7 dot matrix)
- ② Combined normal and half dot positions: 1.3 mm × 2.9 mm (7×7 dot matrix)

Dot intervals (vertical × horizontal)

- ① Normal dot positions: 0.315 mm × 0.423 mm (5×7 dot matrix)
- ② Combined normal and half dot positions: 0.158 mm × 0.423 mm (7×7 dot matrix)

Print speed (for consecutive printing at 25°C)

- ① Per dot line: Approx. 54 ms (13.2VDC) to 65 ms (10.8VDC)
- ② For 5×7 dot matrix +3-dot line spacing: Approx. 2.3 lps (13.2VDC) to 1.9 lps (10.8VDC)

Paper feeding

(equipped with paper free function)

Method : Friction

Paper feeding

pitch : After the printing of one dot line, paper feeding can be controlled to select a 0, 1, 3 or 4 dot line pitch.

Control method : Timing is selected by charging the trigger coil

Fast feeding speed (at 25°C)

: Approx. 7.4 ips (13.2VDC) to 6.1
ips (10.8VDC)

Paper (supplied by the user)

Ordinary paper

Width : 76 ± 0.5 mm
Diameter : 83 + 0 mm (outer dia. of roller paper)
Thickness : 0.06 ~ 0.085 mm
Weight : 52.3 gm/m² ~ 64 gm/m² (45 ~ 55
kg/1000 sheets/1091 × 788 mm)

Multi-form copy paper

(up to one original sheet + 2 copies)

Width : 76 ± 0.5 mm
Diameter : 83 + 0 mm (outer dia. of roller paper)
Thickness : 0.05 ~ 0.08 mm per sheet for a
combined total of 0.2 mm or less

Inking

Method : Dedicated ribbon cassette
Ribbon feed : Automatically fed during motor
rotation

Ribbon cassette (supplied by the user)

Standard : ERC-23
Cassette size : Approx. 122 (W) × 64 (D) × 20.8 (H)
mm
Ribbon colors : Purple or black (Model-260)
Both red and black (Model-262)
Ribbon life : (for consecutive printing at 12VDC
and 25°C)
[Purple] Approx. 1,500,000 cha-
racters
[Black] Approx. 1,500,000 cha-
racters
[Red/black] Approx. 700,000 cha-
racters each
(For details, refer to the "Model-
260/262 Specifications."

Motor

Terminal voltage : 12VDC ± 10%
Average current : Approx. 0.2A (for 12VDC at 25°C)
Peak current : Approx. 0.7A (for 12VDC at 25°C)
Worst case : 1A or less

Print solenoids (Dot head unit)

Quantity : 7 solenoids
Drive voltage : 12VDC ± 10%
D.C. resistance : Approx. 3.7Ω (at 25°C)
Average current : Approx. 0.1A per solenoid (for
12VDC at 25°C)
Peak current : Approx. 3A per solenoid

Trigger coil

(for paper feeding and ribbon-color switching)

Drive voltage : 12VDC ± 10%
D.C. resistance
value : Approx. 47Ω (at 25°C)

Detectors

Timing detector : Tachogenerator (directly coupled to
motor)

Reset detector

Mechanical contact point

Contact point

ratings : Rated voltage = 2.85 ~ 15VDC
Rated current = 20μA ~ 0.3mA

Connection method

Printer side : Pin connector

Rating = BS20P-SHF-1AA

(made by Nippon Compression
Terminals)

Circuit side (supplied by the user)

: Connector

Rating = H20P-SHF-AA

(made by Nippon Compression
Terminals)

Guaranteed operating temperature

: 0° ~ 50°C

Reliability

① Head life

100 million strokes/1 wire (1.5 million × 5 charac-
ters per head; 1 character = 14 strokes)

② Non-head components

MCBF = 1,500,000 lines

External dimensions of printer (W × D × H)

① Model-260: 122 × 83.6 × 25.4 mm

② Model-262: 122 × 83.6 × 33 mm

Weight of printer (including ribbon cassette)

① Model-260: Approx. 340 gm

② Model-262: Approx. 350 gm

Options

Manual knob

1.1.3 Mechanisms

This micro dot printer (both Model-260 and -262) consists of five mechanisms: the transmission mechanism, detection mechanism, printing mechanism, paper feeding mechanism, and ribbon feeding mechanism.

Figs. 1-3 and 1-4 respectively show an external view of the Model-260 and -262 Micro Dot Printer. For details on the operating principles and handling of each mechanism, see section 1.2, "OPERATING PRINCIPLES," and Chapter 2, "HANDLING, MAINTENANCE, AND REPAIR."

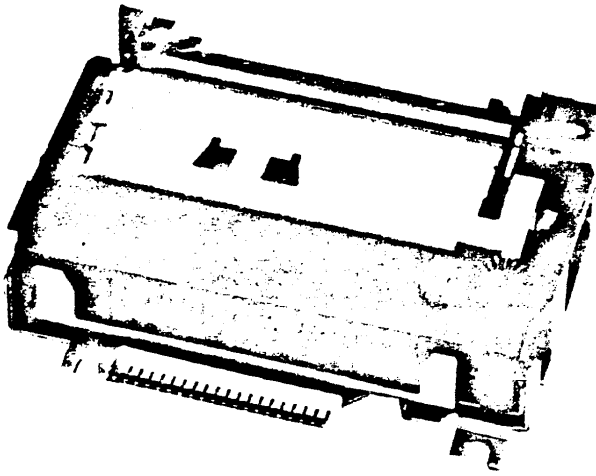

Fig. 1-3. Model-260 Exterior View

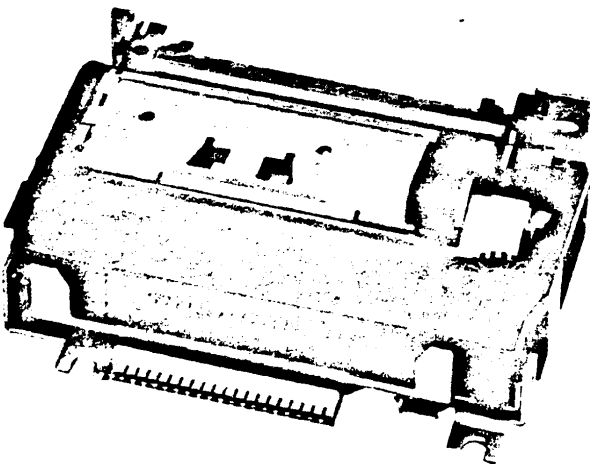

Fig. 1-4. Model-262 Exterior View

1.2 OPERATING PRINCIPLES

1.2.1 Transmission Mechanism

This mechanism consists of the reduction gear series, paper feeding gear series, ribbon feeding gear series, and (for Model-262 only) the ribbon-switching gear series.

Reduction Gear Series (see Fig. 1-5)

The reduction gear series within the reduction unit consists of the first reduction gear fixed to the motor shaft, the second reduction gear (formed by the second reduction gear wheel and the second reduction pinion), and the internal gear built into the carrier driving cam ass'y.

The second reduction gear wheel engages with the first reduction gear and the second reduction pinion is engaged with the internal gear of the carrier driving cam ass'y, they are both sequentially reduced and the rotation force is then transmitted to the carrier driving cam ass'y.

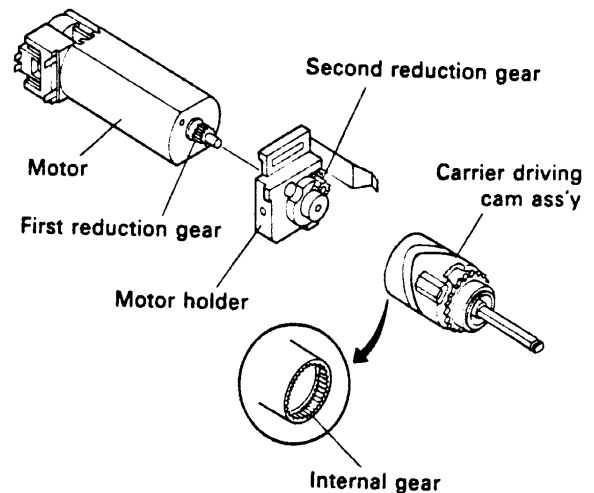

Fig. 1-5. Reduction Gear Series

Paper Feeding Gear Series (see Fig. 1-6)

The paper feeding gear series consists of the paper feeding gear and the paper feeding driving gear, which are both fixed to the paper feeding shaft.

The paper feeding driving gear is engaged with the paper feeding lever within the frame ass'y so that the paper feeding driving gear is rotated reciprocally in the \square arrow (c) and (d) directions by the up/down movement (▀ arrow (a) and (b) directions) of the paper feeding lever. The paper feeding gear is only engaged when the paper feeding gear rotates in the \square arrow (c) direction, intermittently rotating in the ▀ arrow (e) direction in one or three

teeth units according to the stroke size of the paper feeding lever.

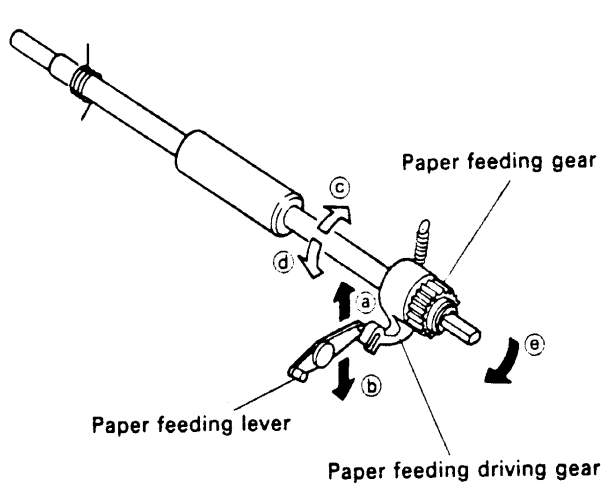

Fig. 1-6. Paper Feeding Gear Series

Ribbon Feeding Gear Series (see Fig. 1-7)

The ribbon feeding gear series consists of the ribbon driving gear, ribbon gear, and the ribbon transmission gear which integrates a bevel gear and pinion. When the ribbon driving gear rotates in the arrow (a) direction, the bevel gear which is engaged to the ribbon driving gear also rotates in the arrow (b) direction. The pinion, which is mounted on the same shaft as the bevel gear, is engaged to the ribbon gear. Therefore, rotation of the bevel gear causes the ribbon gear to rotate in the arrow (c) direction.

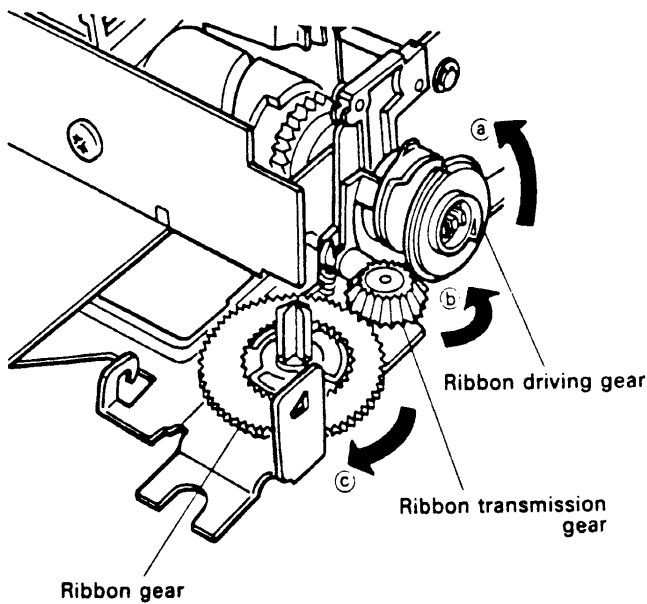

Fig. 1-7. Ribbon Feeding Gear Series

Ribbon Switching Gear Series (see Fig. 1-8)
(Model-260 Only)

The ribbon switching gear series consists of the gear integrated with the trigger yoke holder fixed to the carrier driving camshaft of the carrier driving cam ass'y,

and the switching gear which is built into the carrier driving cam shaft holder ass'y and is engaged with the gear of the trigger yoke holder.

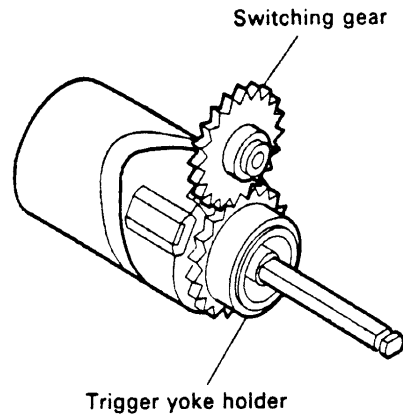

Fig. 1-8. Ribbon Switching Gear Series

1.2.2 Detection Mechanism

Consisting of the Timing (T) detection mechanism and the Reset (R) detection mechanism, the detection mechanism plays an important role in the development of the operating status at each section of the Model-260/262 printer mechanism.

T Detection Mechanism

As shown in Fig. 1-9, the T detection mechanism consists of a tachogenerator that is directly coupled to the motor. As a result, it generates the positive sine wave T_n (Timing signal) of a frequency in proportion to the rotating speed of the motor, and the selection of this Timing signal determines the timing for printing and for driving the trigger coil.

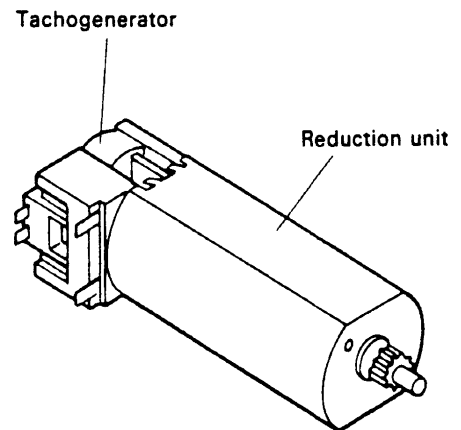

Fig. 1-9. T Detection Mechanism

R Detection Mechanism

As shown in Fig. 1-10, the R detection mechanism is a mechanism switch that consists of two components: the R detection ass'y (plate brush) which is fixed to the frame ass'y, and the R detection plate (conductor) which is

fixed to the carrier driving cam ass'y. Upon one rotation (one dot line) of the carrier driving cam ass'y, the switch enters MAKE status and generates a Reset signal.

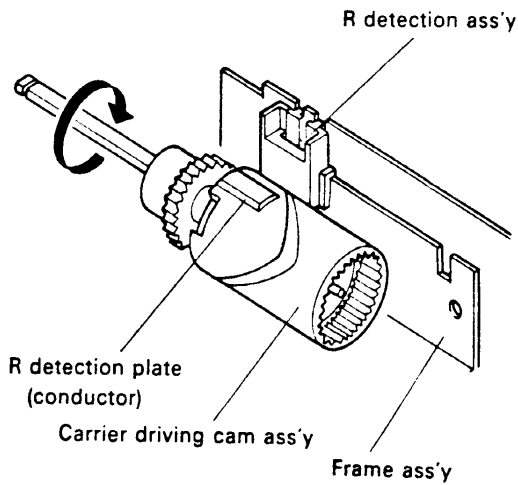

Fig. 1-10. R Detection Mechanism

1.2.3 Printing Mechanism

As shown in Fig. 1-11, the printing mechanism consists of a dot head unit with a parallel arrangement of seven pairs of coils, a guide shaft, return support spring, carrier driving cam ass'y, and paper guide unit.

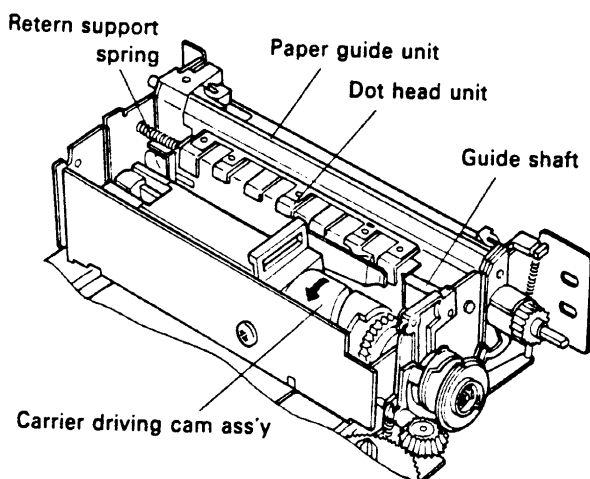

Fig. 1-11. Printing Mechanism

Printing Operation of Head (see Fig. 1-12)

● The movement of the printing plate during the printing of one dot is described as follows:

① When the coils are charged, the actuating iron core is drawn (in the **➡** arrow **Ⓐ** direction) toward the iron core.

- ② When the actuating iron core is drawn, the printing plate moves in the **➡** arrow **Ⓑ** direction around its fulcrum point, and the printing wire which is integrated with the printing plate is projected in the **➡** arrow **Ⓑ** direction toward the platen of the paper guide unit (the status indicated by the broken line).
- ③ When the projected printing wire strikes the platen ass'y through the ribbon and paper, one dot is printed.
- ④ When the charge to the coils is ended, both the printing plate and actuating iron core are returned to their original positions by spring force of the printing plate spring, where they assume standby status (indicated by the solid line).

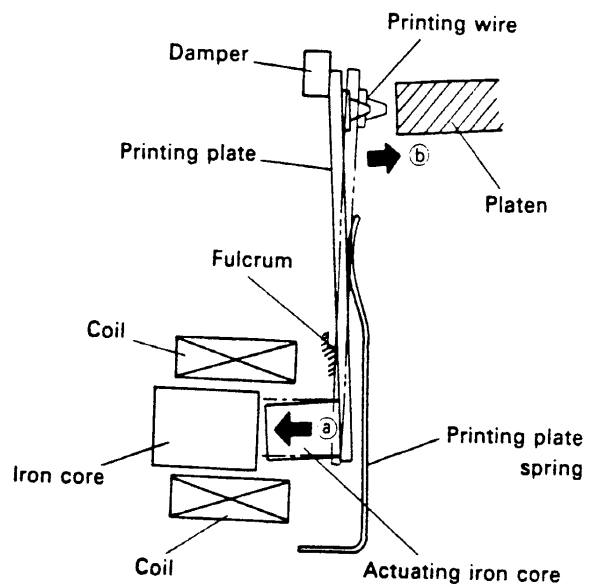

Fig. 1-12. Operation of the Printing Plate

- **One dot line is formed as follows:** (see Fig. 1-13)
 - ① Charge pulse P1, which is formed by the first Timing signal T1 following detection of Reset signal R, is concurrently applied to Coils A to G, then P1 (the dot the right edge of each coil) is printed.
 - ② Charge pulse P2, which is formed by T2, is next

concurrently applied to Coils A to G, then P2. (the second dot from the right edge of each coil) is printed.

- ③ Next, the coils are repeatedly and sequentially charged by Charge pulses P3 to P30 so that one dot line is formed.

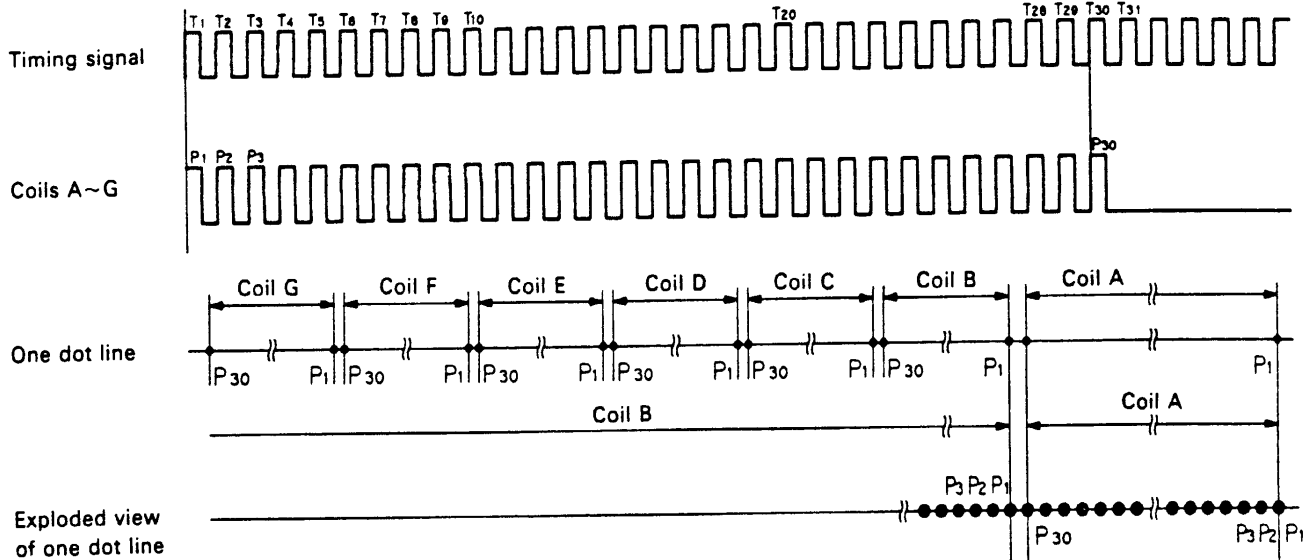

Fig. 1-13. Timing Chart for Forming One Dot Line

1.2.4 Paper Feeding Mechanism

This mechanism consists of the paper feeding cam, paper feeding cam lever, trigger lever, trigger coil, paper guide unit, release lever, and so on.

Besides having one mechanism for normal paper feeding and another for fast feeding, the paper feeding mechanism also has a paper free mechanism which lets the paper be freely pulled straight out in the direction of paper feeding or the reverse direction. Fig. 1-14 shows the paper feeding mechanism.

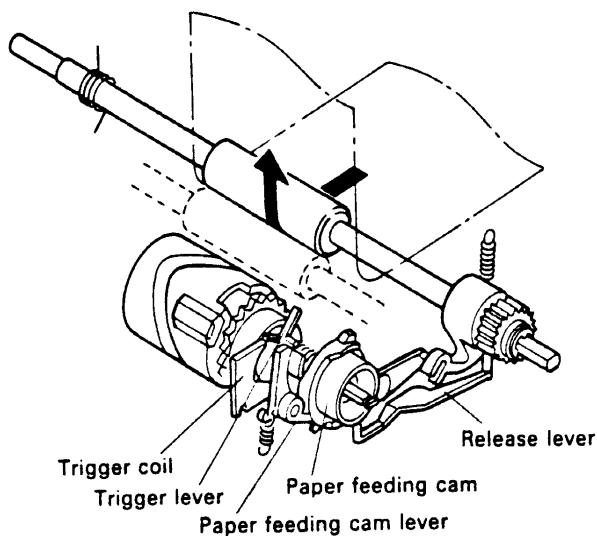

Fig. 1-14. Paper Feeding Mechanism

Operation of the Paper Feeding Lever

(see Fig. 1-15)

The paper feeding cam incorporates Cams 1 and 2, which are engaged with the paper feeding cam lever and

control movement in the thrust direction, and Cams 3 and 4, which are engaged with Pin "A" of the paper feeding lever and control the up/down movement of the paper feeding lever. When the paper feeding cam rotates in the \blacktriangleright arrow (a) direction, the paper feeding cam lever, Cam 1, and Cam 2 cause the paper feeding cam to slide in the direction of the carrier driving camshaft. The paper feeding lever becomes engaged with Cams 3 and 4, and rotates around "B" as its fulcrum point so that section "C" moves up and down in the \blacktriangleright arrow (c) and (d) directions. During the usual rotation of the paper feeding cam, however, Cams 1 and 2 cause it to slide in the carrier driving camshaft direction at the point where Pin "A" of the paper feeding lever, Cam 3, and Cam 4 would become engaged. Therefore, Pin "A" cannot engage with Cams 3 and 4 and the paper feeding lever will not operate.

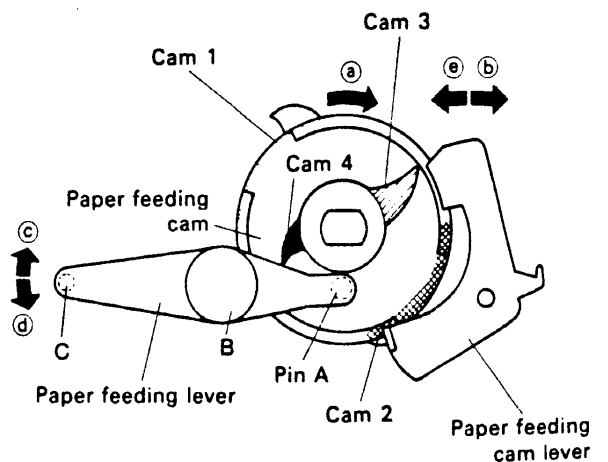

Fig. 1-15. Operation of the Paper Feeding Lever

Paper Feeding Operation for One Dot Line

(see Figs. 1-16 and 1-17)

When the trigger coil is charged with the prescribed pulse after the paper feeding cam rotates in the \blacktriangleright arrow \textcircled{a} direction shown in Fig. 1-16 and just before Cam 2 of the paper feeding cam engages with paper feeding cam lever, the trigger plate is drawn toward the trigger coil, adheres closely to the trigger yoke holder of the carrier driving cam ass'y, then rotates in the \square arrow \textcircled{a} direction shown in Fig. 1-17.

Moreover, this rotating force is also transmitted to the trigger lever built into the trigger plate and rotates the trigger lever in the \square arrow \textcircled{a} direction shown in Fig. 1-17. This causes the trigger lever and paper feeding cam lever to become disengaged so that the paper feeding cam lever rotates in the \blacktriangleright arrow \textcircled{b} direction of Fig. 1-16 and the \square arrow \textcircled{b} direction of Fig. 1-17, and the tip of the paper feeding cam lever separates from the track of Cam 2 of the paper feeding cam. Because the paper feeding cam will not slide in the carrier driving camshaft direction while the paper feeding cam lever is free, Cam 4 and Pin "A" of the paper feeding cam lever become engaged, Pin "C" of the paper feeding lever moves up and down (\blacktriangleright arrow \textcircled{c} and \textcircled{d} directions) the distance of one pitch, and the paper is fed one dot line forward.

When the paper feeding cam rotates further, the paper feeding cam lever is rotated in the \blacktriangleright arrow \textcircled{e} direction by Cam 5 which is integrated with the outer periphery of the paper feeding cam so that the paper feeding cam returns to its original position.

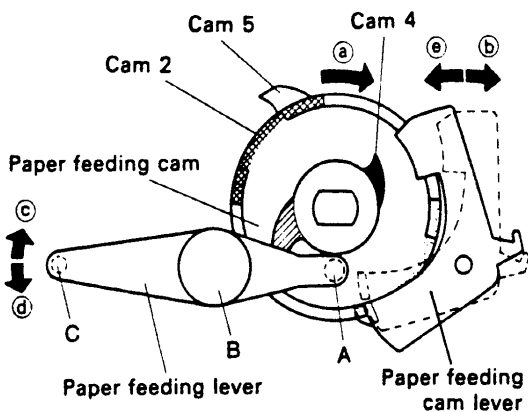

Fig. 1-16. Paper Feeding Operation for One Dot Line

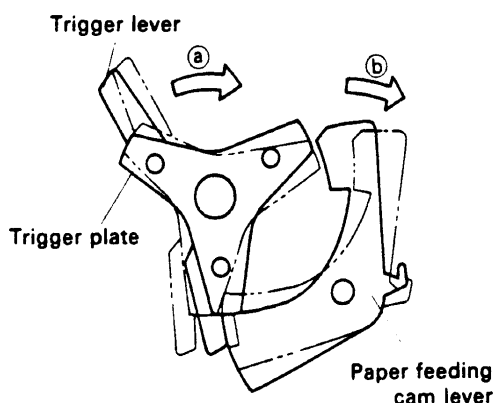
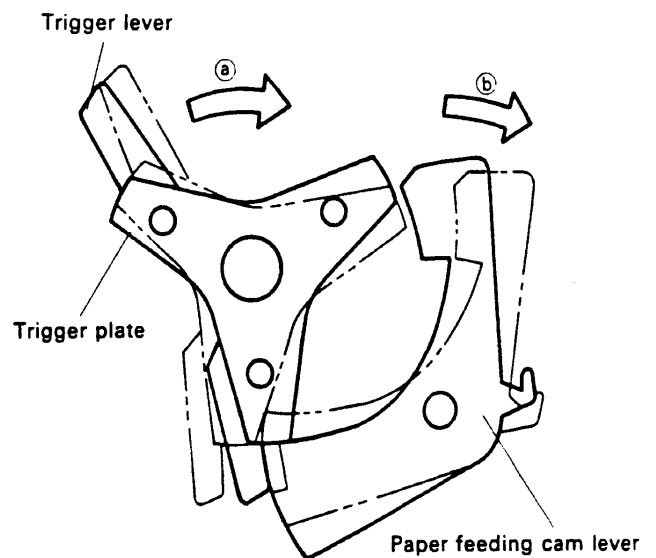

Fig. 1-17. Trigger Lever Operation During Paper Feeding

Paper Feeding Operation for Three Dot Lines

(see Fig. 1-18)

When the trigger coil is charged with the prescribed pulse after the paper feeding cam rotates in the \blacktriangleright arrow \textcircled{a} direction and just before Cam 1 of the paper feeding cam engages with paper feeding cam lever, the trigger plate, trigger lever, and paper feeding cam lever rotate in the \square and \blacktriangleright arrow \textcircled{b} directions (just as the case of one dot line paper feeding), and the tip of the paper feeding cam lever separates from the track of Cam 1 of the paper feeding cam. Because the paper feeding cam will not slide in the carrier driving camshaft direction while the paper feeding cam lever is free, Cam 3 and Pin "A" of the paper feeding cam lever become engaged, Pin "C" of the paper feeding lever moves up and down (\blacktriangleright arrow \textcircled{c} and \textcircled{d} directions) the distance of three pitches, and the paper is fed three dot lines forward. When the paper feeding cam rotates further, the paper feeding cam lever is rotated in the \blacktriangleright arrow \textcircled{e} direction by Cam 6 which is integrated with the outer periphery of the paper feeding cam so that the paper feeding cam returns to its original position.



<Trigger Lever Operation During Paper Feeding>

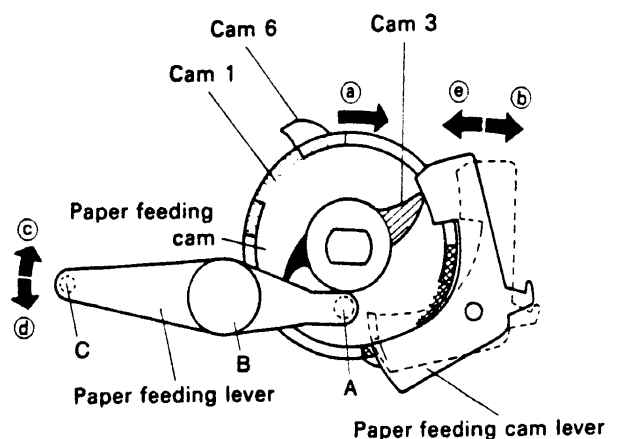

Fig. 1-18. Paper Feeding Operation for Three Dot Lines

Fast Feeding Operation

During fast feeding, the paper is fed four (1 + 3) dot lines forward by charging the trigger coil twice during one rotation of the paper feeding cam.

Operation of the Paper Feeding Driving Gear and Paper Feeding Gear (see Figs. 1-19 and 1-20)

The paper feeding driving gear is engaged with the paper feeding lever and repeats a reciprocating rotating movement as a result of the up/down movement of the paper feeding lever. The paper feeding gear becomes engaged with the paper feeding driving gear with respect to only one direction of the reciprocal rotation of the paper feeding driving gear, and thus performs intermittent rotation.

Paper Feeding Mode (see Fig. 1-19)

When the paper feeding lever is rotated in the \blacktriangleright arrow (a) direction by Cams 3 and 4 of the paper feeding cam, the paper feeding driving gear is rotated in the \blacktriangleright arrow (b) direction and engages with the paper feeding gear. The paper feeding gear thus performs intermittent rotation the distance of one or three teeth in the \blacktriangleright arrow (c) direction, the paper feeding roller on the same shaft also rotates at the same time in the \blacktriangleright arrow (d) direction, and the paper is fed.

Return (see Fig. 1-19)

When the paper feeding driving gear is rotated in the \square arrow (e) direction by the spring force of the paper feeding driving gear spring, the paper feeding lever also rotates in the \square arrow (f) direction. The paper feeding driving gear is returned to its original position by riding over the teeth of the paper feeding gear. Because the detent spring prevents rotation of the shaft at this time, the paper feeding gear becomes disengaged from the paper feeding driving gear, and only the paper feeding driving gear rides over the teeth of the paper feeding gear to rotate in the opposite direction and return to its original position.

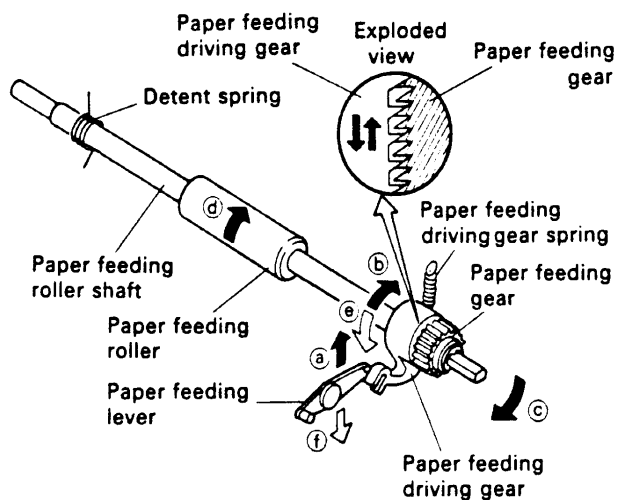

Fig. 1-19. Operation of the Paper Feeding Driving Gear and Paper Feeding Gear

Paper Free Operation (see Fig. 1-20)

The release lever is shifted in the \square arrow (a) direction by Cams 1 and 2 of the paper feeding cam, the paper feeding driving gear is slid in the \square arrow (b) direction, and the teeth of the paper feeding driving gear and of the paper feeding gear become disengaged so that the paper feeding gear is free to rotate in the \square arrow (c) and (d) directions (hereafter referred to as the "Paper Free status").

Even in the status where the paper feeding cam has rotated in the \square arrow (f) direction and Cam 7 is stopped so that cam control cannot be performed, Cams 1 and 2 of the paper feeding cam and the paper feeding cam lever will slide the paper feeding cam in the \square arrow (e) direction to maintain the Paper Free status.

Because this printer normally stops in Paper Free status under usual operation (but not after abnormal termination due to trouble, etc.), the paper can be simply pulled out in the forward or reverse direction and can also be fed in both directions using the manual knob <option>.

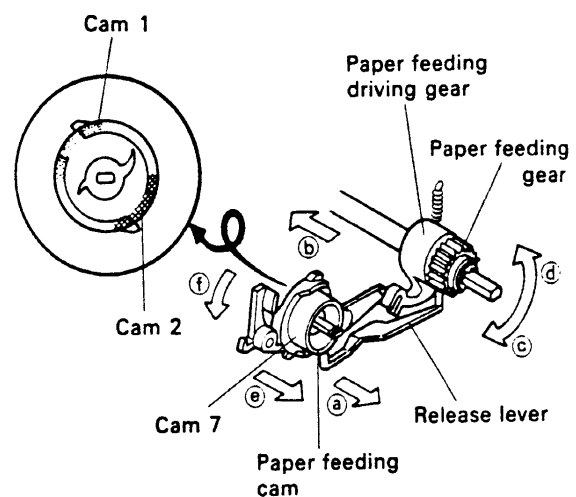

Fig. 1-20. Paper Free Operation

1.2.5 Ribbon Feeding Mechanism

The ribbon feeding mechanism of this printer consists of the ribbon driving gear, ribbon transmission gear, ribbon gear, ribbon rolling shaft, and a ribbon cassette that employs an endless ribbon. It is constructed so that rotation of the motor will cause the ribbon to be fed. Fig. 1-21 shows the ribbon feeding mechanism.

Ribbon Feeding Operation (see Fig. 1-21)

When the ribbon driving gear – which is integrated at its outer periphery with a cam formed from a linear section and lead section – rotates in the \square arrow (a) direction, the ribbon transmission gear – which is engaged with the ribbon driving gear and integrates a bevel gear and pinion – intermittently rotates in the \square arrow (b) direction, causing the ribbon gear engaged with the pinion of the ribbon transmission gear to intermittently rotate in the \square arrow (c) direction. Because the ribbon rolling shaft receives the intermittent rotation

of the ribbon gear then becomes engaged with the ribbon feeding roller (an internal component of the ribbon cassette), the ribbon feeding roller rotates to intermittently feed the ribbon (in the \odot arrow \textcircled{d} direction).

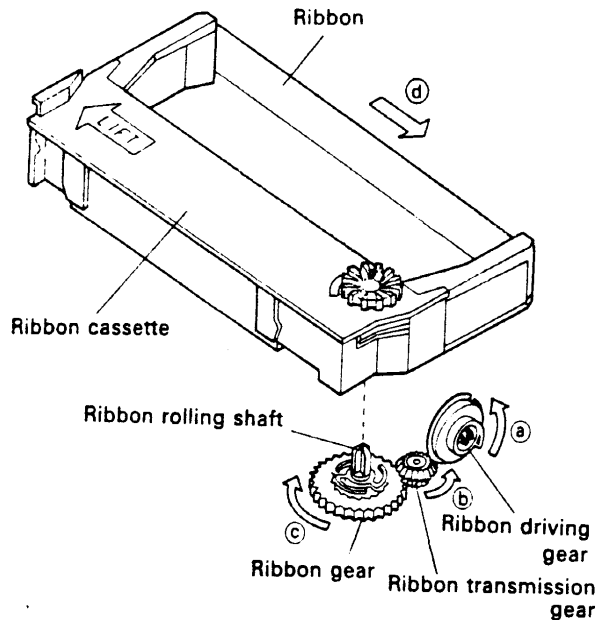

Fig. 1-21. Ribbon Feeding Mechanism

1.2.6 Ribbon Switching Mechanism (Model-262 Only)

As shown in Fig. 1-22, this mechanism consists of the ribbon frame and the carrier driving cam shaft holder ass'y (clutch control lever, switching clutch plate, switching gear, switching cam, etc.). It controls the switching of the ribbon color by use of the trigger coil employed during control of paper feeding.

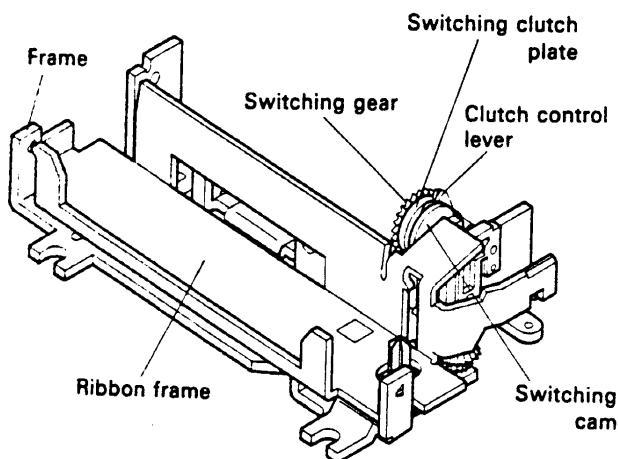

Fig. 1-22. Ribbon Switching Mechanism

Black Printing Status (see Fig. 1-23)

In the status for the black printing position, section "A" of the ribbon frame is engaged with the low lead section of the cam built into the switching cam, and the switching trigger lever is engaged with the pawl "A" of the switching clutch plate.

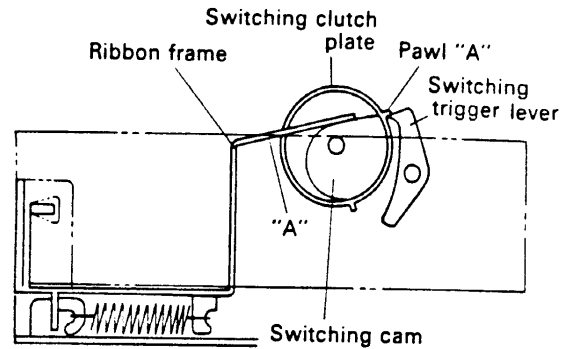

Fig. 1-23. Black Printing Status

Red Printing Status (see Fig. 1-24)

In the status for the red printing position, section "A" of the ribbon frame is engaged with the high lead section of the cam built into the switching cam then becomes tilted, and the switching trigger lever is engaged with pawl "B" of the switching clutch plate.

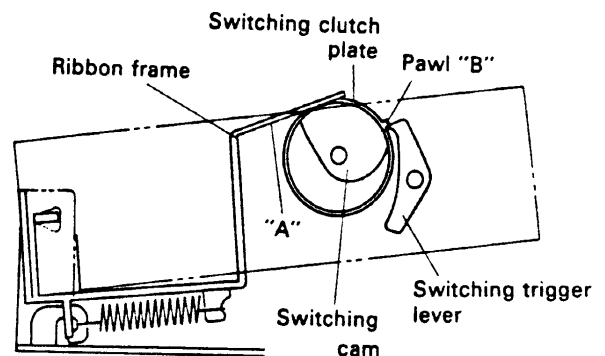

Fig. 1-24. Red Printing Status

Operation of Clutch Control Lever (see Fig. 1-25)

The switching gear has a built-in cam section which engages with the clutch control lever. When the switching gear rotates in the \blacktriangleright arrow \textcircled{a} direction, the cam section of the switching gear rotates the clutch control lever in the \blacktriangleright arrow \textcircled{b} direction so that the clutch control lever engages with the pawl of the switching clutch plate. When the switching gear rotates further, the control over the clutch control lever by the cam section is canceled, then the clutch control lever rotates in the \blacktriangleright arrow \textcircled{c} direction and becomes disengaged from the

pawl of the switching clutch plate. During one rotation of the switching gear, the clutch control lever makes two reciprocal rotating movements.

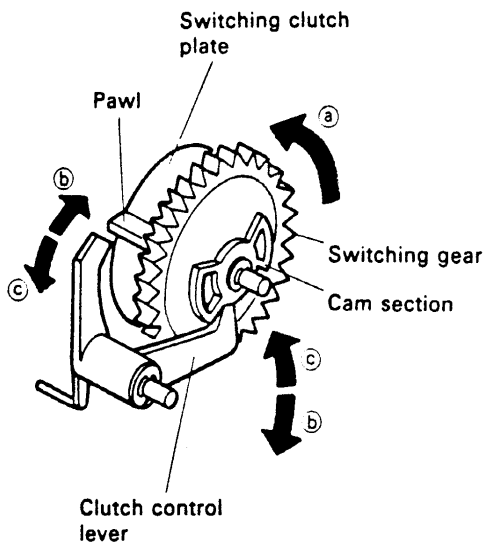

Fig. 1-25. Operation of Clutch Control Lever

Operation of Switching Clutch (see Fig. 1-26)

- ① The switching trigger lever rotates in the \blacktriangleright arrow \textcircled{a} direction and becomes disengaged from the pawl of the switching clutch plate.
- ② Upon disengagement, while rotating the switching clutch plate in the \blacktriangleright arrow \textcircled{b} direction, the switching clutch pawl moves in the \blacktriangleright arrow \textcircled{c} direction around the fulcrum point of the switching camshaft to become engaged with the built-in pawl of the switching gear.

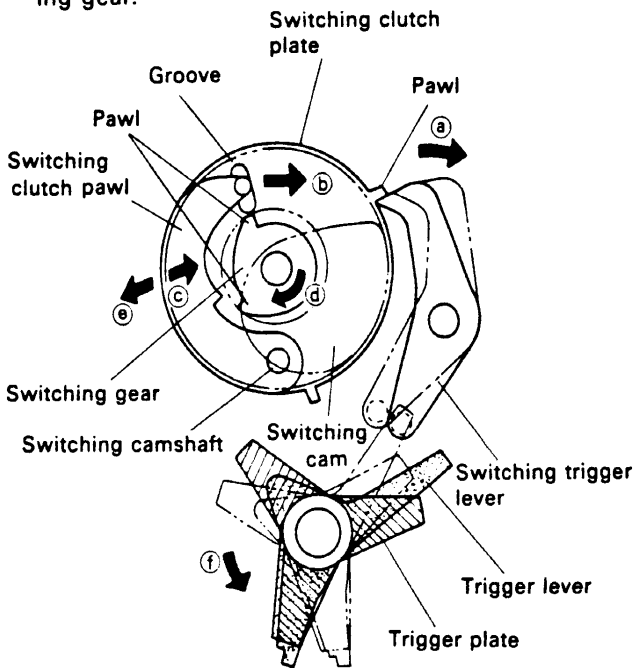

Fig. 1-26. Operation of Switching Clutch

- ③ Upon engagement with the pawl, because the switching gear's rotating force in the \blacktriangleright arrow \textcircled{d} direction is transmitted to the switching clutch pawl, switching clutch plate, and switching cam, they are respectively rotated in the \blacktriangleright arrow \textcircled{e} direction.

- ④ When the switching clutch plate rotates the prescribed amount and the pawl at its outer periphery becomes engaged again with the switching trigger lever, the switching clutch plate stops rotating, and the switching clutch pawl is moved in the \blacktriangleright arrow \textcircled{e} direction by the groove of the switching clutch plate so that it becomes disengaged from the pawl of the switching gear.
- ⑤ When the switching clutch pawl stops, the rotation of the switching cam stops and the switching gear continues rotating without its pawl becoming engaged.

Initialization (see Figs. 1-23, 24, and 1-26)

When the printer power is switched ON, this mechanism cannot distinguish whether the ribbon position is red or black, and thus requires initialization.

- ① When the trigger coil is charged with the prescribed pulse (see "1. Initialization" of the "Model-262 Operating Description," on page 1-14), the trigger plate is drawn toward the trigger coil, adheres to the trigger yoke holder of the carrier driving cam ass'y, then rotates in the \blacktriangleright arrow \textcircled{f} direction shown in Fig. 1-26. The rotating force is also transmitted to the trigger lever which is combined with the trigger plate so the trigger lever is rotated in the \blacktriangleright arrow \textcircled{f} direction of Fig. 1-26.
- ② Rotation of the trigger lever causes the switching trigger lever to rotate in the \blacktriangleright arrow \textcircled{a} direction of Fig. 1-26.
- ③ Rotation of the trigger lever disengages it from the switching clutch plate so that the switching clutch plate and switching cam rotate in the \blacktriangleright arrow \textcircled{d} direction.
- ④ When the trigger coil is recharged at the moment that the switching makes a 50% rotation after the initial charging, because the switching clutch plate continues rotating if the ribbon switching mechanism was in black printing status (Fig. 1-23), the mechanism will not operate despite operation of the switching trigger lever. If initially in the red printing status (Fig. 1-24), the switching clutch plate will be stopped by the switching trigger lever and the black printing status (Fig. 1-23) will be assumed, so the switching trigger lever rotates in the \blacktriangleright arrow \textcircled{a} direction, it becomes disengaged from the switching clutch plate, then the switching clutch plate and switching cam begin rotating once more.
- ⑤ When the switching gear rotates further and the trigger coil is charged with the prescribed pulse, the switching trigger lever rotates. Consequently, the switching trigger lever becomes disengaged from the switching clutch plate, the switching cam rotates, and the ribbon switching mechanism switches from the red status to black status then assumes standby mode.

Red/Black Switching

(see Figs. 1-23, 1-24, 1-25, and 1-26)

When the trigger coil is charged with the prescribed pulse (see "3. Ribbon Red/Black Switching" of the

"Model-262 Operating Description," on page 1-15), the switching trigger lever rotates and becomes disengaged from the switching clutch plate, and the switching cam rotates (Fig. 1-26). Next, if the mechanism either switches to red status (Fig. 1-24) if it was in black status (Fig. 1-23), or switches to black status (Fig. 1-23) if it was in red status (Fig. 1-24).

At this time, because the clutch control lever is engaged with the pawl of the switching clutch plate due to the cam of the switching gear, the switching clutch plate does not rotate in the \blacktriangleright arrow (a) direction (Fig. 1-25) and the ribbon color is not switched.

1.2.7 Printer Operation

Model-260 Operating Description

1. Paper Feeding (see Fig. 1-27)

(a) One dot line feeding

- ① The Motor Drive signal is applied and the Timing signals T following motor start-up are counted. The Reset signal R following the 45th Timing signal T is regarded as R1 and the first Timing signal T after the rise of R1 is regarded as T1.

NOTE: Because the Reset signal R is approximately 2.5 times wider than Timing signal T, if a Reset signal

R is generated at the time the 45th Timing signal is counted, the next Reset signal R (Because chattering sometimes occurs at the rise of Reset signal R, the Reset signal R will be detected again after the 3rd Timing signal T is counted.) is regarded as R1 and the first Timing signal T after the rise of R1 is regarded as T1.

- ② By applying Drive pulses T28 to T30 to the trigger coil, the paper is fed forward one dot line.
- ③ The charge to the motor can be switched OFF after T55.

(b) Three dot line feeding

- ① Identical to Step ① of (a).
- ② By applying Drive pulses T1 to T3 to the trigger coil, the paper is fed forward three dot lines.
- ③ The charge to the motor can be switched OFF after T28.

(c) Four dot line feeding

- ① Identical to Step ① of (a).
- ② By applying Drive pulses T1 to T3 and T28 to T30 to the trigger coil, the paper is fed forward four (3 + 1) dot lines.
- ③ The charge to the motor can be switched OFF after T55.

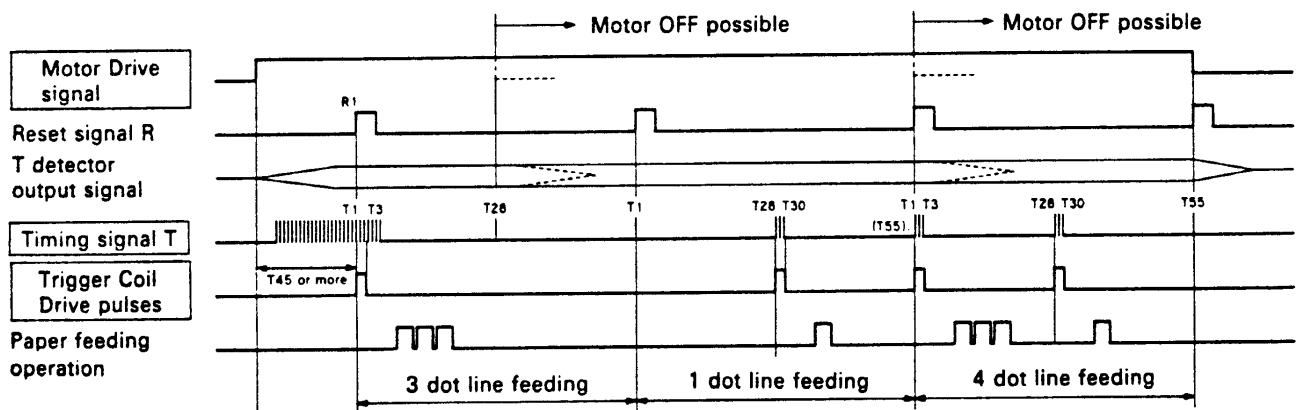

Fig. 1-27. Timing Chart of Paper Feeding (Model-260)

2. Printing (see Figs. 1-28, 1-29, and 1-30)

(a) 5×7 dot matrix with 3 dot line spacing

- ① Identical to Step ① of 1.(a).
- ② By applying the Drive pulse formed at T1A to Print Solenoids A to G, the top right dot of the characters in Columns 1, 6, 11, 16, 21, 26, and 31 is printed.
- ③ By applying the Drive pulse formed at T2A to Print Solenoids A to G, the second-from-the-right top dot of the characters in Columns 1, 6, 11, 16, 21, 26, and 31 is printed.
- ④ Sequentially following the above control process, by applying the Drive pulse formed at T30A to Print Solenoids A to G, the top left dot of the characters in Columns 5, 10, 15, 20, 25, 30, and 35 is printed, thus completing the printing of one dot line.

- ⑤ After printing is completed, the dot head is returned to its home position during the interval between T31 and T55.
- ⑥ By charging the trigger coil during the interval from T28 to T30, the paper is fed one dot line forward.
- ⑦ By consecutively performing the above Steps ② to ⑥ for seven dot lines and applying the Drive pulse formed at T354A to Print Solenoids A to G, the bottom left dot of the characters in Columns 5, 10, 15, 20, 25, 30, and 35 is printed, thus completing the printing of a character having a 5×7 dot matrix.
- ⑧ By charging the trigger coil during the interval from T379 to T381, fast feeding of the paper (three-pitch paper feeding during one reciprocal movement of the dot head) is performed so that a three dot line

spacing is achieved.

⑨ In case of consecutive printing, R9 of Reset signal R is regarded as R1 and the above process is repeated from Step ②.

⑩ To quit printing, switch OFF the Motor Drive signal at T406 to stop the motor.

NOTE: During one print cycle, the Timing signals T shall be counted with reference to R1 of Reset signal R.

During one print cycle, the count value of Timing signals T shall not be reset at other generated Reset signals R, that is, at R2 to R8.

(b) 7×7 (including half dots) dot matrix with 3 dot line spacing

① Identical to Step ① of 1.(a).

② By applying the Drive pulse formed at T1A to Print Solenoids A to G, the top right dot of the characters in Columns 1, 7, 13, 19, 25, 31, and 37 is printed.

③ By applying the Drive pulse formed at T2B to Print Solenoids A to G, a dot is printed between the second-from-the-right top dot and third-from-the-right top dot of the characters in Columns 1, 7, 13, 19, 25, 31, and 37. (Half-dot printing)

④ Sequentially following the above control process, by applying the Drive pulse formed at T30A to Print Solenoids A to G, the top left dot of the characters in Columns 6, 12, 18, 24, 30, 36, and 42 is printed, thus completing the printing of one dot line.

NOTE: By applying the Drive pulse formed at T30B to the Print Solenoids, printing can also be performed between the 30th and 31st dots of each

Print Solenoid.

⑤ After printing is completed, the dot head is returned to its home position during the interval between T31 and T55.

⑥ By charging the trigger coil during the interval from T28 to T30, the paper is fed one dot line forward.

⑦ By consecutively performing the above Steps ② to ⑥ for seven dot lines and applying the Drive pulse formed at T354A to Print Solenoids A to G, the bottom left dot of the characters in Columns 6, 12, 18, 24, 30, 36, and 42 is printed, thus completing the printing of a character having a 7×7 dot matrix.

⑧ Identical to Step ⑧ of 2.(a).

⑨ Identical to Step ⑨ of 2.(a).

⑩ Identical to Step ⑩ of 2.(a).

NOTE: During one print cycle, the Timing signals T shall be counted with reference to R1 of Reset signal R.

During one print cycle, the count value of Timing signals T shall not be reset at other generated Reset signals R, that is, at R2 to R8.

The minimum driving cycle of the print solenoids shall be the interval between two Timing signals.

(c) Bit-image printing

In case bit images will be printed, T1 is detected according to Step ① of 1.(a), then printing is performed according to Timing signals T which are continuously counted until no more bit images exist.

NOTE: Regarding the quantity of consecutive charges to the print solenoids, refer to the separate "Model-260/262 Specifications."

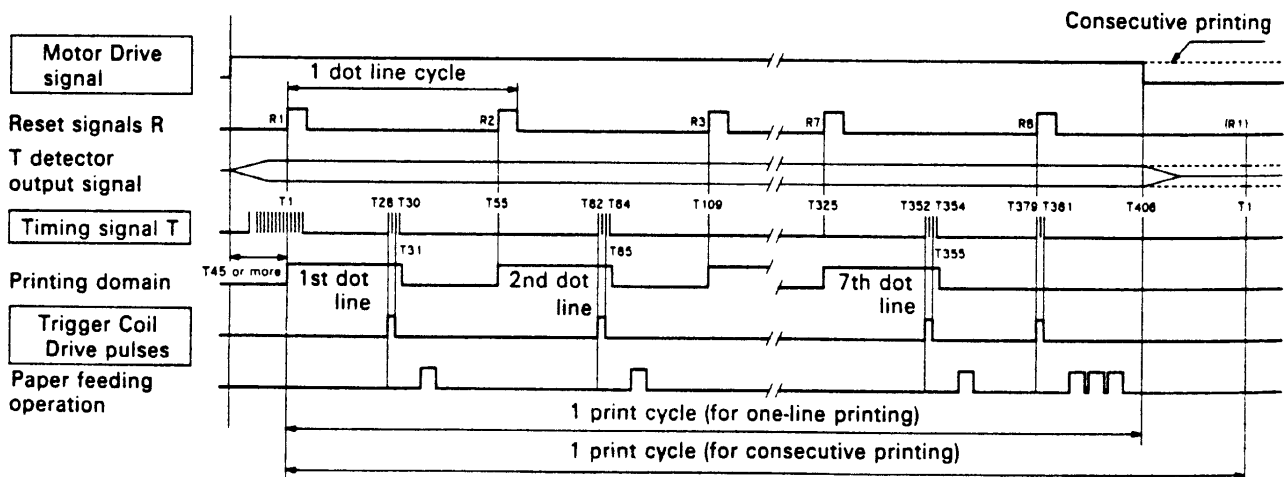
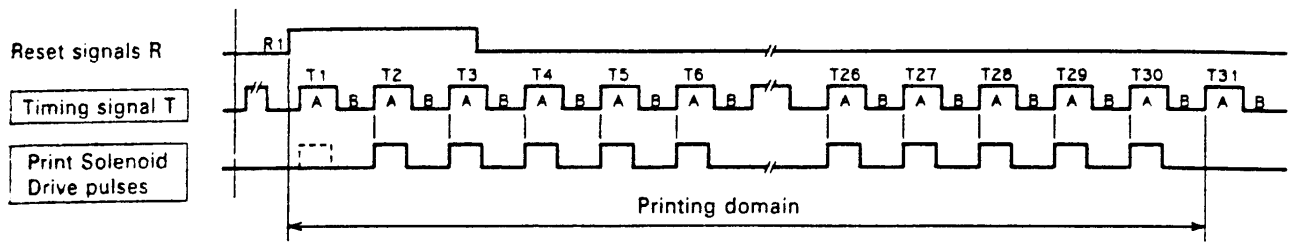

Fig. 1-28. Timing Chart of Printing (Model-260)

< Exploded View of One Dot Line >



< Printing Example >

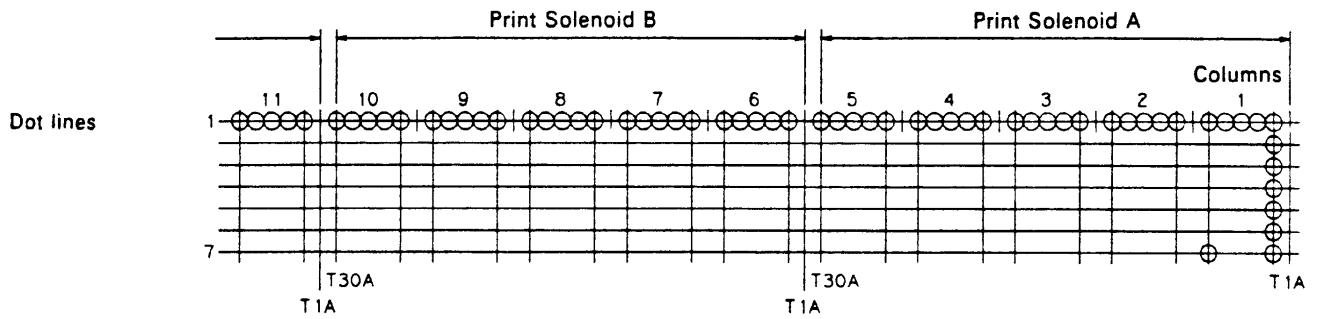
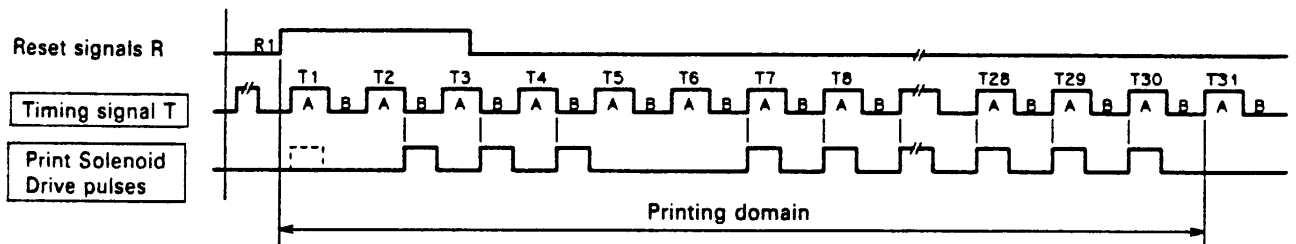

Fig. 1-29. 5×7 Dot Matrix (Model-260)

< Exploded View of One Dot Line >



< Printing Example >

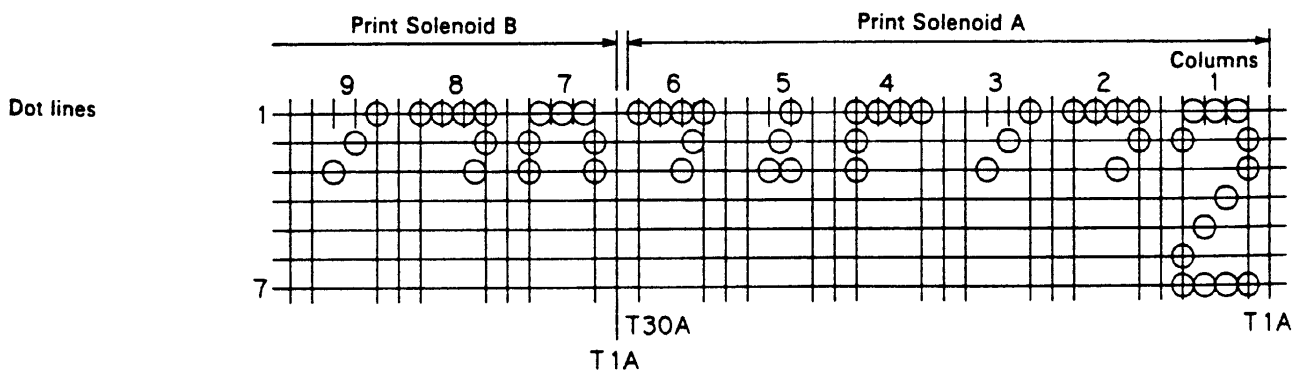

Fig. 1-30. 7×7 Dot Matrix (Model-260)

Model-262 Operating Description

1. Initialization (see Fig. 1-31)

Because the color status (red or black) is unclear when the printer power is switched ON or when the printer recovers from an Error status, initialization is required.

- ① The Motor Drive signal is applied and the Timing signals T following motor start-up are counted. The Reset signal R following the 45th Timing signal T is regarded as R1 and the first Timing signal T after the rise of R1 is regarded as T1.

NOTE: Because the Reset signal R is approximately 2.5 times wider than Timing signal T, if a Reset signal

R is generated at the time the 45th Timing signal is counted, the next Reset signal R (Because chattering sometimes occurs at the rise of Reset signal R, the Reset signal R will be detected again after the 3rd Timing signal T is counted) is regarded as R1 and the first Timing signal T after the rise of R1 is regarded as T1.

- ② By applying Drive pulses T16 to T18, T43 to T45, and T124 to T126 to the trigger coil, the ribbon is set to its black position.
- ③ The charge to the motor can be switched OFF after T163.

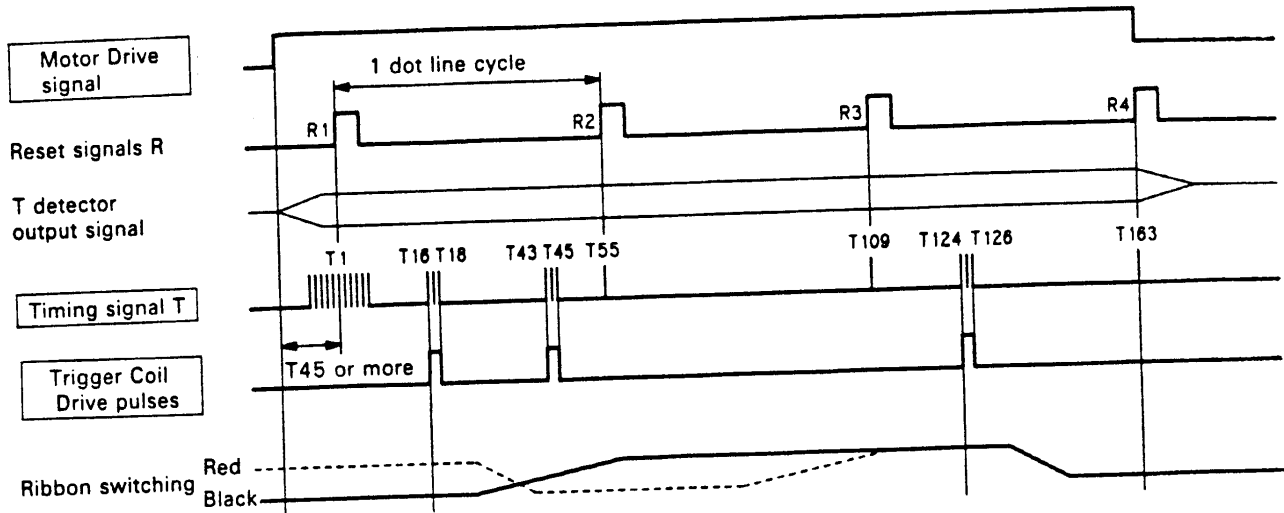

Fig. 1-31. Timing Chart of Initialization (Model-262)

2. Paper Feeding (see Fig. 1-32)

(a) One dot line feeding

- ① Identical to Step ① of "1. Initialization."
- ② By applying Drive pulses T28 to T30 to the trigger coil, the paper is fed forward one dot line.
- ③ The charge to the motor can be switched OFF after T55.

(b) Three dot line feeding

- ① Identical to Step ① of "1. Initialization."
- ② By applying Drive pulses T1 to T3 to the trigger coil,

the paper is fed forward three dot lines.

- ③ The charge to the motor can be switched OFF after T28.

(c) Four dot line feeding

- ① Identical to Step ① of "1. Initialization."
- ② By applying Drive pulses T1 to T3 and T28 to T30 to the trigger coil, the paper is fed forward four (3 + 1) dot lines.
- ③ The charge to the motor can be switched OFF after T55.

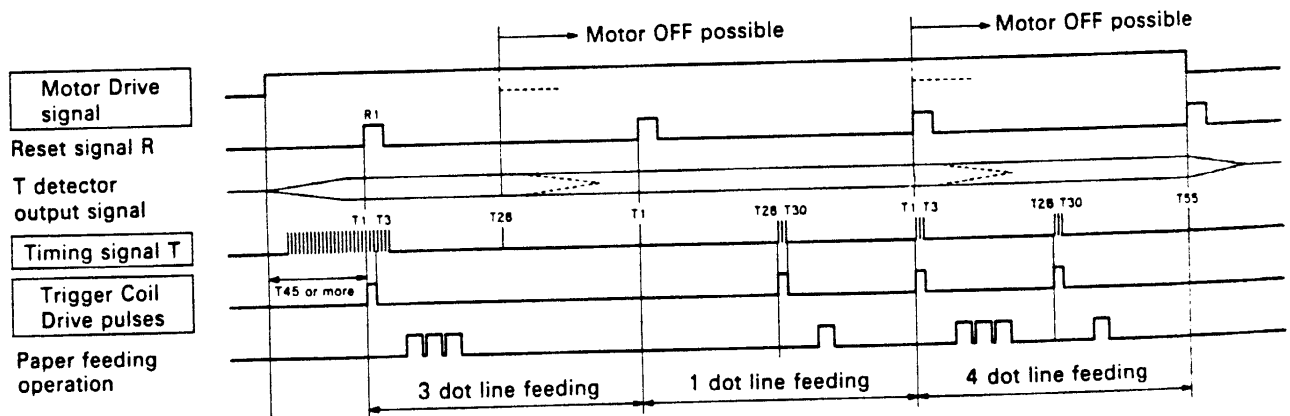

Fig. 1-32. Timing Chart of Paper Feeding (Model-262)

3. Ribbon Red/Black Switching (see Fig. 1-33)

- ① Identical to Step ① of "1. Initialization."
- ② By applying Drive pulses T16 to T18 to the trigger coil, the ribbon will either be switched from red status to black status or from black status to red status.

- ③ After T82, it is possible to either stop the motor or continue printing.

NOTE: Paper feeding and ribbon color switching must not be performed at the same time.

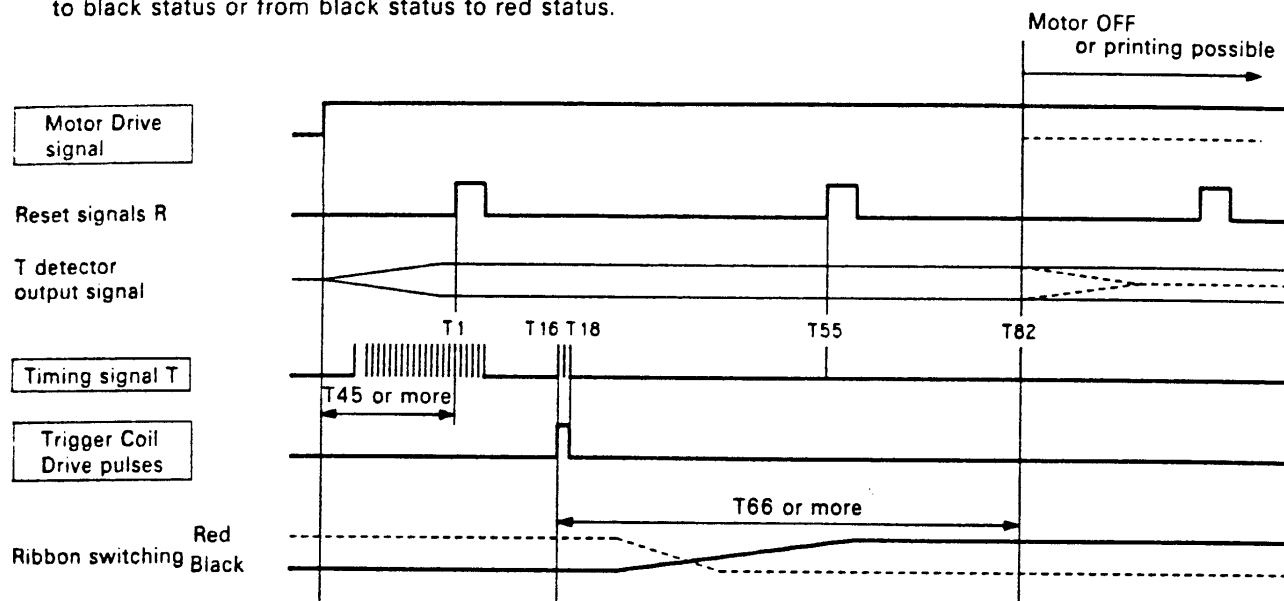

Fig. 1-33. Timing Chart of Ribbon Red/Black Switching

4. Printing (see Figs. 1-34, 1-35, and 1-36)

- (a) 5×7 dot matrix with 3 dot line spacing
 - ① Identical to Step ① of "1. Initialization."
 - ② By applying the Drive pulse of T1 to Print Solenoids A to G, the top right dot of the characters in Columns 1, 6, 11, 16, 21, 26, and 31 is printed.
 - ③ By applying the Drive pulse of T2 to Print Solenoids A to G, the second-from-the-right top dot of the characters in Columns 1, 6, 11, 16, 21, 26, and 31 is printed.
 - ④ Sequentially following the above control process, by applying the Drive pulse of T30 to Print Solenoids A to G, the top left dot of the characters in Columns 5, 10, 15, 20, 25, 30, and 35 is printed, thus completing the printing of one dot line.
 - ⑤ After printing is completed, the dot head is returned to its home position during the interval between T31 and T55.
 - ⑥ By charging the trigger coil during the interval from T28 to T30, the paper is fed one dot line forward.
 - ⑦ By consecutively performing the above Steps ② to ⑥ for seven dot lines and applying the Drive pulse of T354 to Print Solenoids A to G, the bottom left dot of the characters in Columns 5, 10, 15, 20, 25, 30, and 35 is printed, thus completing the printing of a character having a 5×7 dot matrix.
 - ⑧ By charging the trigger coil during the interval from T379 to T381, fast feeding of the paper (three-pitch paper feeding during one reciprocal movement of the dot head) is performed so that a three dot line spacing is achieved.
 - ⑨ In case of consecutive printing, R9 of Reset signal R is regarded as R1 and the above process is repeated from Step ②.

- ⑩ To quit printing, switch OFF the Motor Drive signal at T406 to stop the motor.

NOTE: During one print cycle, the Timing signals T shall be counted with reference to R1 of Reset signal R.

During one print cycle, the count value of Timing signals T shall not be reset at other generated Reset signals R, that is, at R2 to R8.

- (b) 7×7 (including half dots) dot matrix with 3 dot line spacing

- ① Identical to Step ① of "1. Initialization."
- ② By applying the Drive pulse formed at T1A to Print Solenoids A to G, the top right dot of the characters in Columns 1, 7, 13, 19, 25, 31, and 37 is printed.
- ③ By applying the Drive pulse formed at T2B to Print Solenoids A to G, a dot is printed between the second-from-the-right top dot and third-from-the-right top dot of the characters in Columns 1, 7, 13, 19, 25, 31, and 37. (Half-dot printing)
- ④ Sequentially following the above control process, by applying the Drive pulse formed at T30A to Print Solenoids A to G, the top left dot of the characters in Columns 6, 12, 18, 24, 30, 36, and 42 is printed, thus completing the printing of one dot line.

NOTE: By applying the Drive pulse formed at T30B to the Print Solenoids, printing can also be performed between the 30th and 31st dots of each Print Solenoid.

- ⑤ After printing is completed, the dot head is returned to its home position during the interval between T31 and T55.
- ⑥ By charging the trigger coil during the interval from T28 to T30, the paper is fed one dot line forward.

- ⑦ By consecutively performing the above Steps ② to ⑥ for seven dot lines and applying the Drive pulse formed at T354A to Print Solenoids A to G, the bottom left dot of the characters in Columns 6, 12, 18, 24, 30, 36, and 42 is printed, thus completing the printing of a character having a 7×7 dot matrix.
- ⑧ Identical to Step ⑧ of 4.(a).
- ⑨ Identical to Step ⑨ of 4.(a).
- ⑩ Identical to Step ⑩ of 4.(a).

NOTE: During one print cycle, the Timing signals T shall be counted with reference to R1 of Reset signal R.

During one print cycle, the count value of Timing signals T shall not be reset at other generated

Reset signals R, that is, at R2 to R8.

The minimum driving cycle of the print solenoids shall be the interval between two Timing signals.

(c) Bit-image printing

In case bit images will be printed, T1 is detected according to Step ① of "1. Initialization," then printing is performed according to Timing signals T which are continuously counted until no more bit images exist.

NOTE: Regarding the quantity of consecutive charges to the print solenoids, refer to the separate "Model-260/262 Specifications."

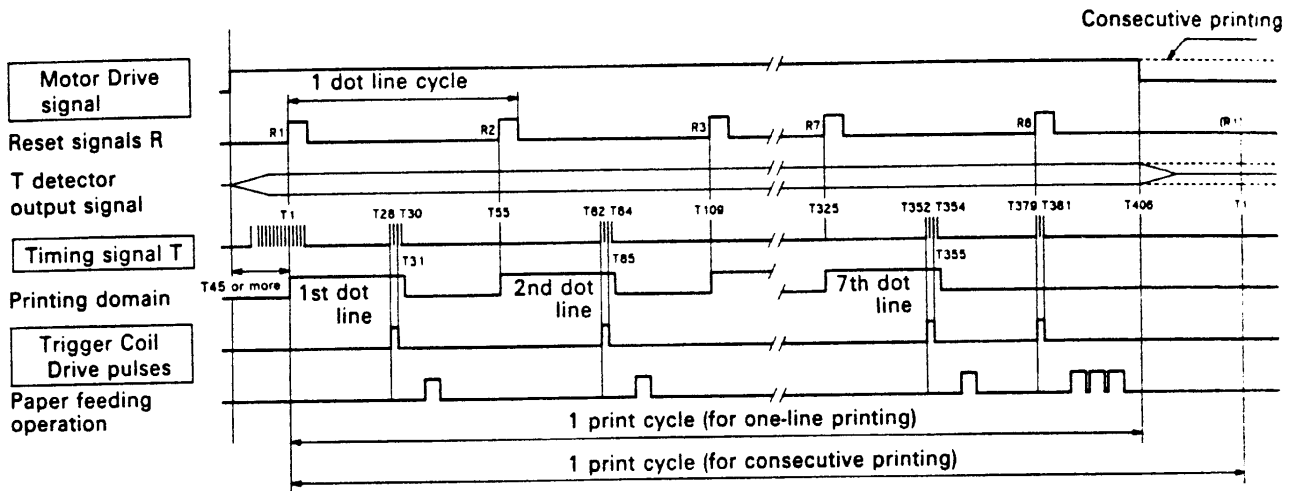
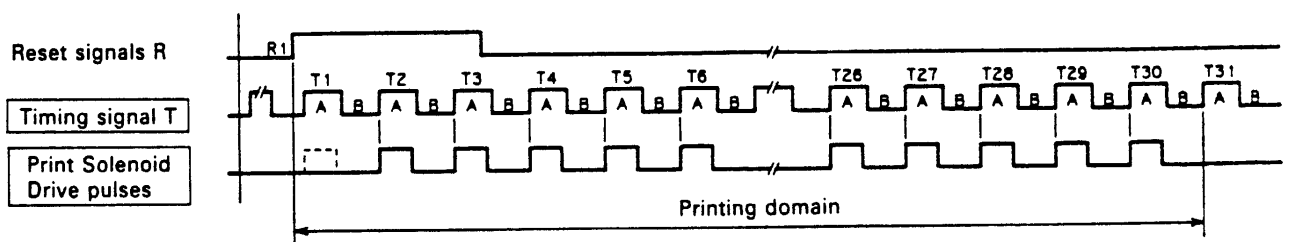

Fig. 1-34. Timing Chart of Printing (Model-262)

< Exploded View of One Dot Line >



< Printing Example >

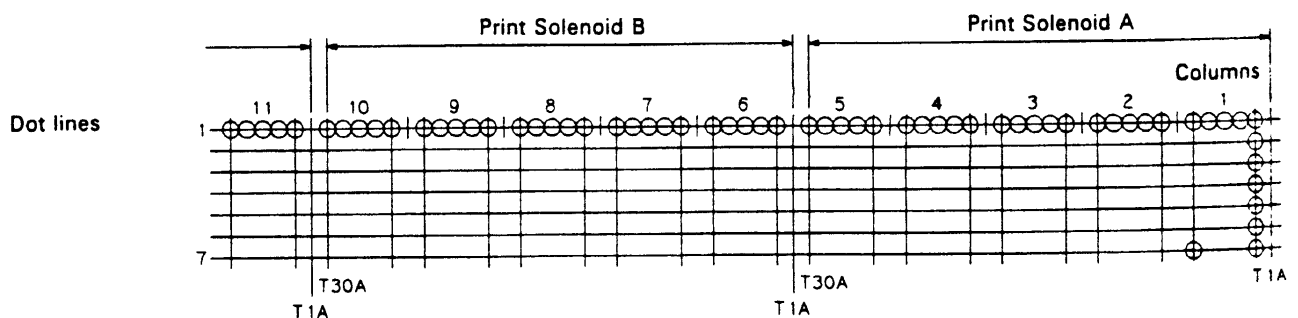
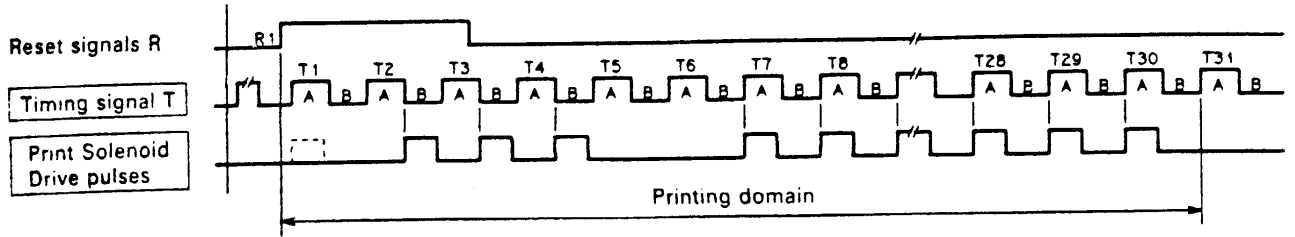

Fig. 1-35. 5×7 Dot Matrix (Model-262)

< Exploded View of One Dot Line >



< Printing Example >

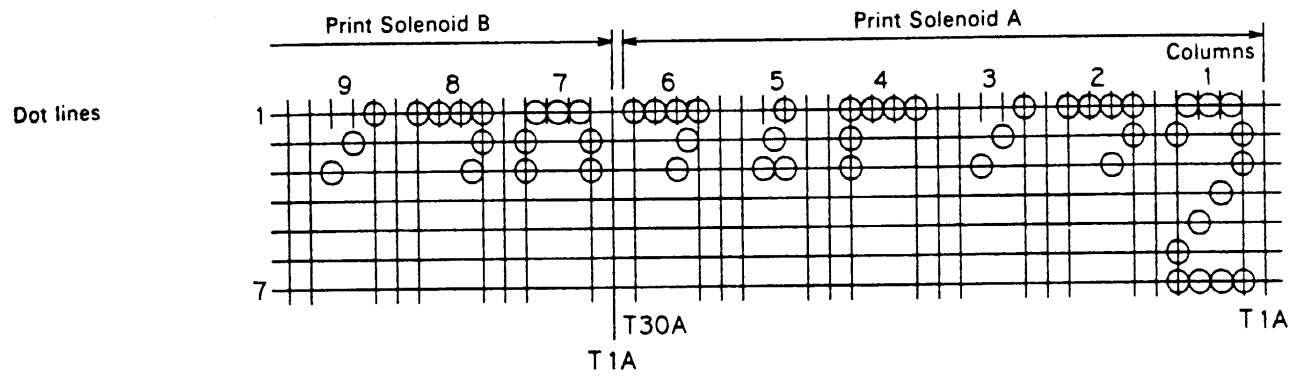

Fig. 1-36. 7×7 Dot Matrix (Model-262)

2.1 HANDLING THE PRINTER

2.1.1 Precautions on Printer Handling

Precautions on Transport

- (1) Never transport the printer by grasping it by its FPC (at the printer bottom), connectors, paper guide unit or gear sections.
- (2) Never expose the printer to external stress nor impact by dropping or striking it, placing two printers into contact or other similar means.

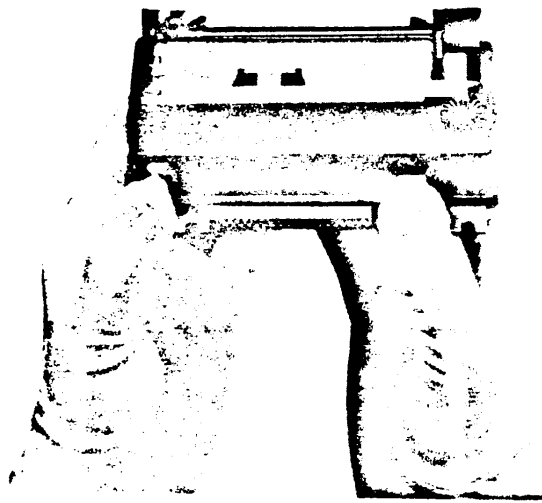

Fig. 2-1. Proper Carrying Method

Precautions on Storage

- (1) Avoid storage in locations exposed to excessive dirt or dust, direct sunlight, and excessive moisture.
- (2) In case of long-term storage, place the printer into a polyethylene bag after wrapping it in anti-rust (VCI) paper, then store it in a dry location.

Precautions on Use

- (1) Since this printer employs a permanent magnet (motor section) and trigger magnets, avoid using it in locations exposed to excessive iron filings, dirt, dust or other foreign particles.
- (2) **Never perform a printing operation without the paper and ribbon cassette installed.**
- (3) Since the ribbon cassette is disposable, never replenish its ink supply.
- (4) Be sure to use only the paper that conforms to our specifications. (See subsection 1.1.2, "Specifications.")
- (5) Be sure to use only the ribbon cassettes that conform to our specifications.
- (6) Never handle the manual knob < optional > during a printing operation.

2.1.2 Paper Setting Procedures

Paper Insertion

When setting paper into the printer, be sure to heed the following precautions:

- (1) Always insert the paper in the direction shown in Fig. 2-2.

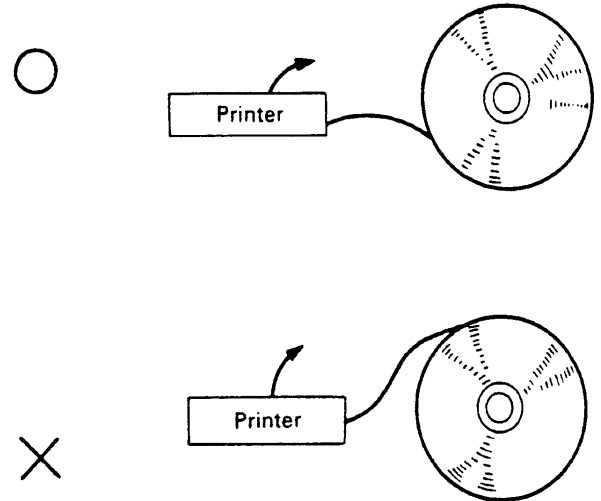

Fig. 2-2. Direction of Paper Insertion

- (2) The paper's leading edge should be as shown in Fig. 2-3.

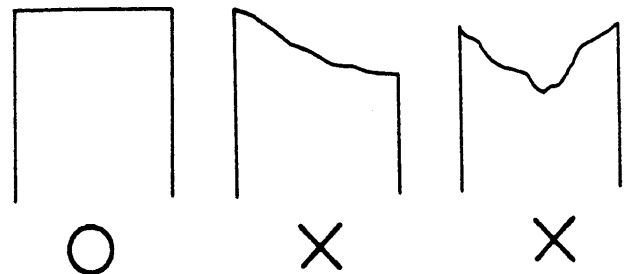

Fig. 2-3. Processing the Paper's Leading Edge

- Always insert the paper straight into the printer. (When setting the paper, its insertion is simplified by pushing the paper in the direction of paper feeding.)

Paper Removal

Whenever the paper is removed, one of the two methods below must be used.





- (1) Perform paper feeding by an electrical operation (switch the printer power ON then press the Paper Feed button), then remove the paper.
- (2) Operate the paper release mechanism (see subsection 1.2.4, "Paper Feeding Mechanism"), then slowly pull the paper straight out in the direction of paper ejection of paper insertion.
- (3) Remove the paper by operating the manual knob < optional >.

Always remove the paper using one of the above methods. Use of other methods shall be avoided as they will cause jamming of the paper.

2.1.3 Installation/Removal of Ribbon Cassette

Be sure that only ribbon cassettes that conform to our specifications are used. Use of non-standard ribbon cassettes shall be strictly avoided as their use may lead to such problems as deteriorated printing quality and durability or ink leakage.

Ribbon Cassette Installation

- (1) Using your fingers, turn the knob of the ribbon cassette in the  direction to take up any slack in the ribbon as shown in Fig. 2-4.
- (2) Insert (in the  direction ①) the ribbon between the dot head unit and the paper guide unit, then set the ribbon in the  direction ②. (See Fig. 2-5.)
- (3) Turn the knob of the ribbon cassette by finger once more in the  direction to confirm that the ribbon cassette is securely installed.

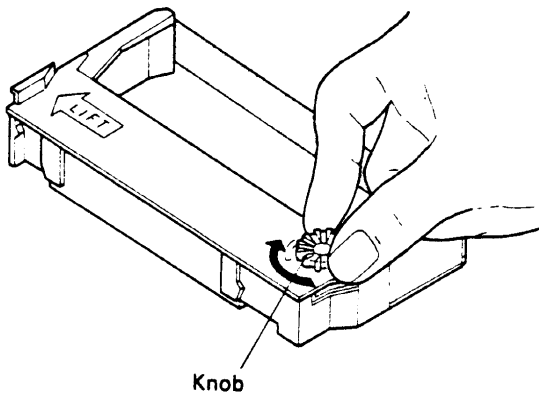

Fig. 2-4. Taking Up Slack in the Ribbon

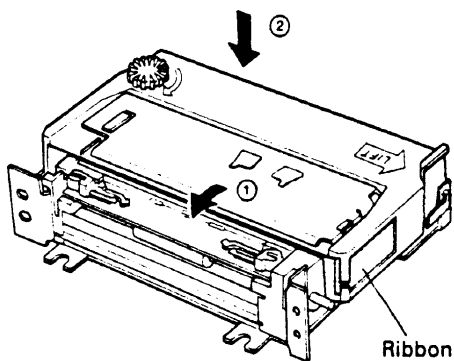



Fig. 2-5. Installation of the Ribbon Cassette

Removal of Ribbon Cassette

- (1) Grasp section "A" of the ribbon cassette with your fingers, then lift the ribbon cassette in the  direction to remove it as shown in Fig. 2-6.

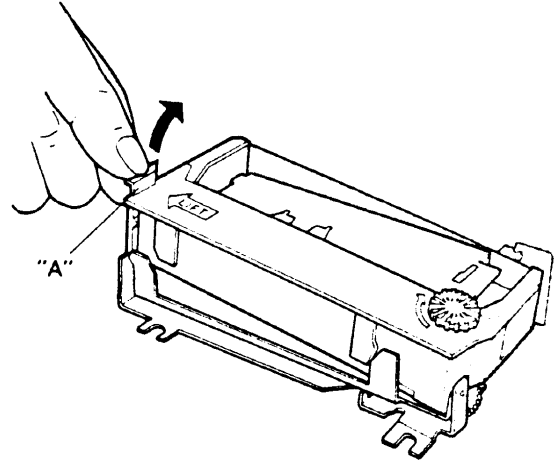

Fig. 2-6. Removal of Ribbon Cassette

CHAPTER 2

HANDLING, MAINTENANCE, AND REPAIR

CONTENTS

2.1	HANDLING THE PRINTER	2- 1
2.1.1	Precautions on Printer Handling	2- 1
2.1.2	Paper Setting Procedures.....	2- 1
2.1.3	Installation/Removal of Ribbon Cassette	2- 2
2.2	MAINTENANCE.....	2- 3
2.2.1	Cleaning.....	2- 3
2.2.2	Inspection.....	2- 3
2.3	LUBRICATION	2- 3
2.3.1	Lubricant Types	2- 3
2.3.2	Lubrication Requirements.....	2- 3
2.3.3	Lubrication Points	2- 4
2.3.4	Adhesive Application Requirement	2- 4
2.3.5	Adhesive Type	2- 4
2.3.6	Adhesive Application Point.....	2- 4
2.4	TOOLS AND LUBRICANTS	2- 4
2.4.1	List of Tools	2- 4
2.4.2	List of Lubricants and Adhesive.....	2- 4
2.5	REPAIR.....	2- 5
2.5.1	Repair Levels.....	2- 5
2.5.2	Repair Procedures	2- 5
2.5.3	Repair Guidelines	2- 5
Fig. 3-2.	Lubrication and Adhesive Application Points of Model-260	3-22
Fig. 3-4.	Lubrication and Adhesive Application Points of Model-262	3-24

2.2 MAINTENANCE

To constantly ensure the maintenance of this printer at its initial performance level throughout a long product life as well as to prevent potential troubles, be sure to perform maintenance according to the points described herein.

2.2.1 Cleaning

Eliminating Stains

Wipe of the soiled sections using alcohol or benzine.

Eliminating Dirt, Scraps and Dust

Use a vacuum cleaner to carefully draw out all foreign particles from every part of the printer.

NOTES:

- (1) Never use thinner, trichloroethylene nor ketone solvents, because they may deteriorate or deform the plastic or rubber components.
- (2) Check the remaining lubrication at each cleaned area, and perform additional lubrication as required (see subsection 2.3.3, "Lubrication Points").

2.2.2 Inspection

The maintenance and inspection procedures for this printer are grouped into two types: 1) daily checks that can be easily performed by the printer's operator during the course of daily work, and 2) periodic checks that should be performed only by persons having a thorough understanding of the printer mechanisms. These procedures are to implemented according to the technical level of the person conducting them.

Daily Check

The printer is checked according to section 2.1, "HANDLING THE PRINTER," to see if the printer is being properly used so that it can always be used under optimum conditions.

Periodic Check

Every six months, periodic maintenance and inspection of the points below should be conducted:

No.	Check Item	Standard	Repair Method
1	Adhesion/penetration of dirt, scraps or dust to the printer parts	<ul style="list-style-type: none"> ● No excessive adhesion of dirt, scraps or dust. No penetration by foreign matter. 	<ul style="list-style-type: none"> ● Use a vacuum cleaner to carefully remove all foreign matter from the printer.
2	Shape of the springs	<ul style="list-style-type: none"> ● No deformed springs 	<ul style="list-style-type: none"> ● Replace any deformed springs.
3	Lubrication status	<ul style="list-style-type: none"> ● See section 2.3, "LUBRICATION." 	<ul style="list-style-type: none"> ● Perform lubrication with reference to section 2.3.
4	Operating check	<ul style="list-style-type: none"> ● No abnormalities in the printing operation. ● No abnormalities in the paper feeding operation. ● Observe each function and check for malfunctioning due to wear, deformation or warping of parts, etc. 	<ul style="list-style-type: none"> ● See subsection 2.5.3, "Repair Guidelines." ● See subsection 2.5.3 and section 2.3.

2.3 LUBRICATION

Lubrication plays a vital role in maintaining this printer at its initial performance level throughout a long product life as well as preventing potential troubles. Make sure to apply the specified lubricant at the specified intervals.

2.3.1 Lubricant Types

The type of oil used greatly influences the printer's performance and durability, and its low-temperature characteristic requires particular attention. Consequently, we have conducted thorough analyses of technical data and various experiments related to diverse oils, and our selection of the oils specified for use with this printer are based on the results of such research.

Note that our specified oils can be supplied in 40-cc (40-gr) metal cans or plastic containers (the minimum supply unit).

The three types of oils used with this printer are: G-18, G-19, and O-3.

2.3.2 Lubrication Requirements

- Prior to lubricating a part during an assembly or disassembly operation, that part must be thoroughly cleaned. Points requiring lubrication and the corresponding lubricant types are listed in the table of subsection 2.3.3, "Lubrication Points," and shown in Figs. 3-2, "Lubrication and Adhesive Application Points of Model-260," and 3-4, "Lubrication and Adhesive Application Points of Model-262." Note that corresponding numbers being used for the table and figures.
- Lubrication should be performed in periodic intervals according to the lubrication classes listed below. If lubrication becomes deficient due to cleaning, disassembly or parts replacement, be sure to perform lubrication regardless of the actual lubrication interval.

A : Lubrication after every six months

B : Lubrication after every overhaul or 1,500,000 printed lines

2.3.3 Lubrication Points (See also Figs. 3-2 and 3-4)

#(1) ~ (19) require lubrication during assembly

No.	Lubrication Point	Oil Type	Class
(1)	Paper feeding cam lever shaft of the frame ass'y	G-19	B
(2)	Contact point between the paper feeding cam lever and the frame ass'y	G-19	A
(3)	Contact point between the frame ass'y and the release lever	G-19	B
(4)	Contact point between the carrier driving cam ass'y and the trigger plate	O-3	B
(5)	Contact point between the carrier driving camshaft and the paper feeding cam	G-18	B
(6)	Internal gear of the carrier driving cam ass'y	G-19	B
(7)	Cam groove of the carrier driving cam ass'y (2 apex points of the cam groove)	G-19	B
(8)	Motor holder hole of the reduction unit	G-19	B
(9)	Sleeve section between the frame ass'y and the dot head unit (both sides)	G-19	B
(10)	Hole at the top of the dot head unit (2 points)	G-19	B
(11)	Contact point between the protruding sections of the dot head unit and the carriage spring	G-19	B
(12)	Contact point between the dot head unit and guide shaft (2 points)	G-19	A
(13)	Outer surface of the R detection plate of the carrier driving cam ass'y	G-19	B
(14)	Contact point between the carrier driving camshaft and the frame ass'y	G-19	B
(15)	Sleeve section between the paper feeding lever and the frame ass'y	G-19	A
(16)	Contact point between the paper feeding lever within the frame ass'y and the paper feeding cam	G-19	A
(17)	Teeth of the bevel gear of the ribbon transmission gear	G-19	A
(18)	Carrier driving camshaft section between the carrier driving cam shaft holder and the paper feeding cam	G-18	B
(19)	Contact point between the paper feeding cam and the paper feeding cam lever	G-19	B
(20)	Paper feeding spring section of the paper guide unit	O-3	A
(21)	Contact point between the paper feeding driving gear and the release lever	G-19	A
(22)	Interlocked section between the paper feeding driving gear and the paper feeding lever within the frame ass'y	G-19	A
(23)	Fulcrum point of the paper feeding lever	G-19	A
(24)	Type-E retainer ring of the ribbon rolling shaft	G-19	A
(25)	Contact point between the paper feeding cam and the release lever	G-19	B

2.3.4 Adhesive Application Requirement

So that the screws of this printer do not become loosened by vibration during transport or other occasions, adhesive has been applied to certain points prior to tightening. Consequently, when performing disas-

sembly or parts replacement, be sure to apply adhesive according to subsection 2.3.6, "Adhesive Application Points" and also Figs. 3-2 and 3-4 at the end of this manual.

2.3.5 Adhesive Type

The adhesive for use with this printer consists of Neji Lock Green #2.

2.3.6 Adhesive Application Point (See also Figs 3-2, 3-4)

No.	Adhesive Application Point	Adhesive Type
(26)	Mounting screw of the circuit board	Neji Lock (G) #2

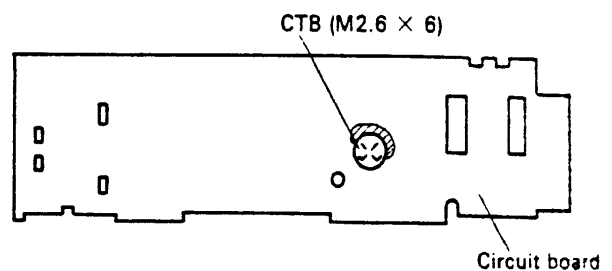

Fig. 2-7 Adhesive Application Point

2.4 TOOLS AND LUBRICANTS

2.4.1 List of Tools

No.	Tool Designation	Availability
1	Brush #1 (Fine)	○
2	Brush #2 (Medium)	○
3	Cleaning brush	○
4	Precision Phillips screwdriver #0	○
5	Precision Phillips screwdriver #1	○
6	Flat screwdriver #1	○
7	Tweezers	○
8	Diagonal cutting nippers	○
9	Electric soldering iron	○
10	ET holder #4	○
11	ET holder #2.3	○
12	Clearance gauges (0.55, 0.6, and 0.65 mm)	○
13	Jig for pressing the trigger lever	Ⓢ

○ Commercially available
Ⓢ Our exclusive product

2.4.2 List of Lubricants and Adhesive

Item	Designation	Volume	Availability
Oil	O-3	40gr	Ⓢ
Grease	G-18	40gr	Ⓢ
	G-19	40gr	Ⓢ
Adhesive	Neji Lock Green #2	500gr	○

○ Commercially available
Ⓢ Our exclusive product

2.5 REPAIR

With consideration of the level of expertise required for implementation of after-service and repair procedures for this printer, such procedures have been grouped into two rankings: Level A and Level B. The person in charge of repair should thus perform the repair procedures appropriate to the required LEVEL cited in subsection 2.5.3, "Repair Guidelines" and to his/her own level of expertise.

2.5.1 Repair Levels

LEVEL A: Requires general knowledge and technical skills regarding the operating principles and construction of the printer, but does not require prior repair experience.

LEVEL B: Requires full knowledge regarding the operating principles and construction of the printer, the necessary expertise for using the tools and measuring instruments for disassembly and assembly, as well as prior repair experience.

2.5.2 Repair Procedures

If a printer problem should occur, carefully checks its symptoms and condition, clarify the source of the problem with reference to subsection 2.5.3, "Repair Guidelines," then repair the damaged area. Note that the tables of "Repair Guidelines" consist of the five following items, enabling troubleshooting and repair to be

performed with speed, efficiency, and minimum errors of judgement.

PHENOMENON

Check the symptoms of the trouble.

CONDITION

Compare the condition of the trouble with the description in this column and locate the matching condition.

CAUSE

This column lists the potential causes of the problem on the basis of its condition, allowing confirmation of the location of the trouble. The required repair LEVEL is also listed according to the cause, so be sure to refer to the LEVEL column before attempting repair.

CHECK POINT AND METHOD

According to the cause, this column lists what parts to check as well as the checking procedure to be used. Be sure to inspect the check points according to the instructions in this column.

REPAIR METHOD

Repair the trouble area according to the instructions in this column. If the original symptoms and condition persist even after repair is performed, check another item of the CAUSE column then perform the pertinent repair.

- To simplify checking procedures during troubleshooting or repair, Fig. 2-8, "Pin Assignment of the Pin Connector" (page 2-8) and Figs. 1-27 to 1-36, "Timing Charts" (pages 1-11 to 1-17) have been included for your reference.

2.5.3 Repair Guidelines

PHENOMENON	CONDITION	CAUSE	LEVEL	CHECK POINT AND METHOD	REPAIR METHOD
1. The motor doesn't rotate.	Motor doesn't rotate or remains locked, despite issuing of Print command	(1) Defective power supply input to the motor	—	● Confirm the input power supply Use a tester or oscilloscope to measure the input voltage between the motor power supply terminals. Rated value: 12 VDC ± 10%	● Inspect and repair the power supply circuit.
		(2) Improper contact between the circuit board and the connector circuit board or a damaged lead wire	B	● Check the conductivity between the circuit board and the connector circuit board.	● If no conductivity exists, perform resoldering or replace the defective board.
		(3) Defective motor	B	● Apply 12V to the motor terminals, then check if the motor rotates.	● If not, replace the reduction unit.
2. No dots are printed.	Motor rotates normally, but no printing is performed	(1) Damaged common wire in the FPC	B	● Check the conductivity between the FPC common lead wires.	● If no conductivity exists, replace the dot head unit.
		(2) Improper contact between the FPC common lead wires and the connector circuit board	B	● Check the conductivity of the soldered section between the FPC common lead wires and the connector circuit board.	● If no conductivity exists, perform resoldering.

PHENOMENON	CONDITION	CAUSE	LEVEL	CHECK POINT AND METHOD	REPAIR METHOD
3. Dots are continuously missing.	Only specific dots are never printed (so certain groups of columns are always skipped).	(1) Improper contact of FPC	B	● Check the conductivity of the soldered section between the pertinent FPC common lead wire and the connector circuit board .	● If no conductivity exists, perform resoldering.
		(2) Damaged FPC lead wire	B	● Check the conductivity between the pertinent FPC terminal and the common lead wire.	● If no conductivity exists, replace the dot head unit.
		(3) Damaged wire of dot head coil	B	● Check if the resistance of the pertinent dot head coil is within rated values. Rated value: Approx. 3.7Ω	● If not, replace the dot head unit.
4. Dots are intermittently missing.	Only specific dots are intermittently missing	(1) Improper contact of FPC	B	● See CAUSE (1) of PHENOMENON 3.	
		(2) Damaged wire of FPC	B	● See CAUSE (2) of PHENOMENON 3.	
	Dots are intermittently missing across all columns	Improper contact of FPC	B	● Check the soldering status between the common terminals of FPC and the connector circuit board .	● If the soldering status is not satisfactory, perform resoldering.
5. The character width fluctuates.	The character width fluctuates only for specific columns.	(1) Wear or damage to the gears	B	● Check the first reduction gear, second reduction gear, and internal gear of the carrier driving cam ass'y for wear and damage.	● In any gear is worn or damaged, replace the reduction unit and the carrier driving cam ass'y.
		(2) Worn cam groove of the carrier driving cam ass'y	B	● Check the cam groove of the carrier driving cam ass'y for wear.	● If worn, replace the carrier driving cam ass'y.
6. Paper feeding cannot be performed.	All printing is done at one line without the paper being fed	(1) Improper paper supply	A	● Check if the paper is of the rated width, thickness, and diameter. ● Check for obstructions in the paper supply path.	● Use only the specified paper. ● Remove any obstructions in the paper supply path.
		(2) Damaged wire of trigger coil	B	● Use a tester to check if the resistance value of the trigger coil is within rated values. Rated value: approx. 47Ω at 25°C	● If not, replace the trigger coil.
		(3) Improper contact or damaged wire between the circuit board and the connector circuit board .	B	● Check the conductivity between the circuit board and the connector circuit board .	● If no conductivity exists, perform resoldering or replace both boards.
		(4) Worn or disconnected spring of the paper feeding driving gear	B	● Check if the spring is worn or disconnected.	● If damaged, replace the spring. ● If disconnected, connect it properly.
		(5) Worn or disconnected spring of the paper feeding cam lever	B	● Check if the spring is worn or disconnected.	● If damaged, replace the spring. ● If disconnected, connect it properly.
		(6) Damage or disengagement of the interlocking section between the paper feeding driving gear and the paper feeding lever	B	● Confirm that the interlocking section between the paper feeding driving gear and paper feeding lever is neither damaged nor disengaged.	● If damaged, replace the paper guide unit. ● If disengaged, perform re-setting for proper engagement.

PHENOMENON	CONDITION	CAUSE	LEVEL	CHECK POINT AND METHOD	REPAIR METHOD
7. The line spacing pitch is not uniform.	The line spacing of the printed paper is not uniform or the characters are defaced	(1) Improper paper supply	A	● See CAUSE (1) of PHENOMENON 6.	
		(2) Worn or disconnected spring of the paper feeding driving gear	B	● See CAUSE (4) of PHENOMENON 6.	
		(3) Worn or disconnected spring of the paper feeding cam lever	B	● See CAUSE (5) of PHENOMENON 6.	
8. The paper cannot be released.	The paper cannot be released despite normal operation of the printing mechanism	(1) Worn or damaged release lever	B	● Check if the release lever is worn or damaged.	● If so, replace it
			B	● Check if the teeth of the paper feeding driving gear and those of the paper feeding gear remain interlocked. (Refer to Fig. 1-20 of Chapter 1.)	
9. The inking mechanism doesn't operate at all.	The inking mechanism doesn't operate at all despite normal operation of the printing mechanism	(1) Defective ribbon cassette	A	● Check if the ribbon of the ribbon cassette is rotating.	● If not, replace the ribbon cassette.
		(2) Worn or damaged ribbon transmission gear	B	● Check if the ribbon transmission gear is worn or damaged.	● If so, replace it.
		(3) Worn or damaged ribbon driving gear, ribbon gear or ribbon rolling shaft	B	● Check if the ribbon driving gear, ribbon gear or ribbon rolling shaft is worn or damaged.	● If so, replace the pertinent component.
10. The color of the ink is not properly switched (Model-262 only)	Switching to red or black printing cannot be performed	(1) Worn or damaged carrier driving cam shaft holder ass'y	B	● Check if the carrier driving cam shaft holder ass'y is worn or damaged.	● If so, replace the carrier driving cam shaft holder ass'y.
		(2) Damaged wire of trigger coil	B	● See CAUSE (2) of PHENOMENON 6.	
		(3) Disconnected or damaged ribbon frame spring	B	● Check if the ribbon frame spring is damaged or disconnected.	● If damaged, replace the spring. ● If disconnected, connect it properly.
		(4) Entry of foreign matter below the ribbon frame	A	● Check if foreign matter has entered below the ribbon frame	● If so, remove it.

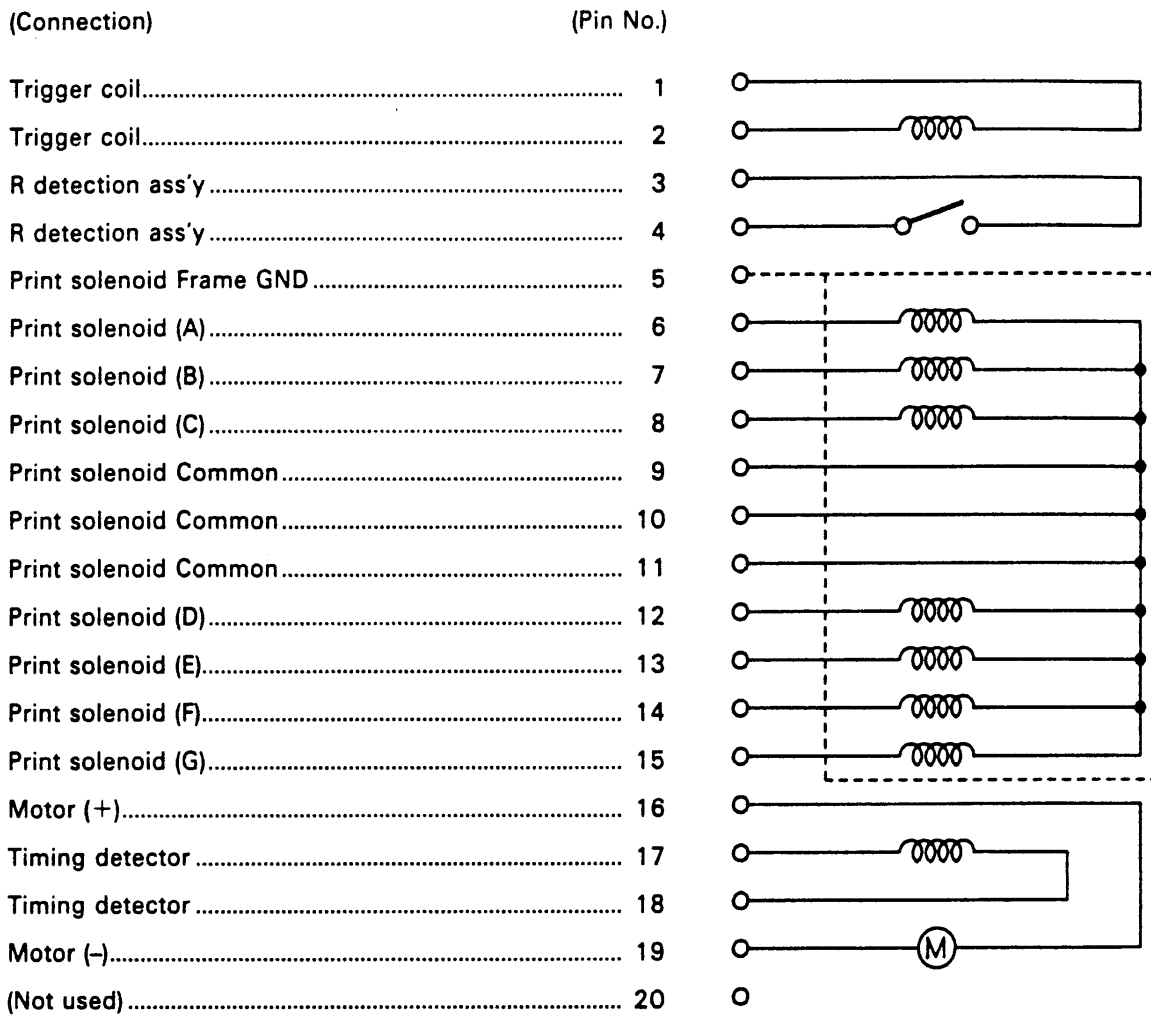

NOTE: The Pin Nos. are counted from 1 to 20 from the right side of the connector.

Fig. 2-8. Pin Assignment of the Pin Connector

CHAPTER 3

DISASSEMBLY, ASSEMBLY AND ADJUSTMENT

CONTENTS

3.1	DISASSEMBLY.....	3- 1
3.2	ASSEMBLY	3- 1
3.2.1	Subassembly.....	3- 2
	Frame Unit.....	3- 2
	Carrier Driving Camshaft Unit.....	3- 5
3.2.2	Main Assembly.....	3- 8
	Frame Unit, Carrier Driving Camshaft Unit, Reduction Unit, and Circuit Board.....	3- 8
	Dot Head Unit, Guide Shaft, and Return Support Spring.....	3-10
	Paper Guide Unit, Connector, and Connector Circuit Board	3-12
	Ribbon Frame	3-15
	Cover and Ribbon Frame.....	3-16
	Soldering	3-18
3.3	ADJUSTMENTS	3-19
	Platen Gap Adjustment	3-19
	Fig. 3-1. Exploded View of Model-260	3-21
	Fig. 3-3. Exploded View of Model-262	3-23

3.1 DISASSEMBLY

- For disassembly, perform the assembly procedures described in section 3.2, "ASSEMBLY," in reverse sequence. Disassemble the main assembly and divide it into the subassemblies, then disassemble each subassembly.
- Disassembly of printer components beyond the examples shown in Figs. 3-1, "Exploded View of Model-260," and 3-3, "Exploded View of Model-262," may result in damage to the printer and its functions, so you are advised not to do so.
- The "☆" (white star) symbol in the "Reassembly Step" column indicates the presence of a <POINT IN DISASSEMBLY> in the "Points of Assembly Work" column, so be sure to refer to such points during disassembly work. If you also confirm the mounting procedures, etc. described in the "Points of Assembly Work" column while performing disassembly, the reassembly process will later be easier to perform.

3.2 ASSEMBLY

- The assembly process is divided into main assembly and subassembly. First, assemble the subassemblies, then proceed to the main assemblies after the components have been somewhat modularized.
- The differences in the reassembly (or disassembly) procedures for Model-260 and Model-262 are indicated at the top right of the pertinent page, so be sure to perform reassembly (or disassembly) using the procedures conforming to the proper model. In case no model is indicated, the procedures listed on that page are common for both models.
- Perform assembly while referring to the component shapes and mounting positions shown in Figs. 3-1 and 3-3 at the end of this manual.
- The "★" (black star) symbol in the "Reassembly Step" column indicates the need for a <CHECK> or <ADJUSTMENT>. Be sure to perform <ADJUSTMENT> procedures according to the detailed descriptions in section 3.3, "ADJUSTMENTS."
Even if only a small amount of disassembly has been performed, confirm the presence/absence of pertinent adjustment points during reassembly.
- Circled numbers in the "Reassembly Step" column indicate that lubrication is required during the reassembly of that component and that such lubrication will be difficult unless performed during reassembly.
- For details on lubrication, including those points which require lubrication after the printer is totally assembled, see subsection 2.3.3, "Lubrication Points," and perform lubrication while also referring to Figs. 3-2, "Lubrication and Adhesive Application Points of Model-260," and 3-4, "Lubrication and Adhesive Application Points of Model-262," at the end of this manual.
- The "◎" symbol in the "Reassembly Step" column indicates that the marked components can be individually supplied, independently of the unit components shown in Figs. 3-1 and 3-3 at the end of this manual.
- All small parts are represented by the abbreviations listed below.
- The actual size of the small parts are shown in the below figure. By referring to this figure while you are mounting them, you can avoid the mistaken use of the wrong small parts.

List of Abbreviations for Small Parts

CS	: <u>C</u> up <u>S</u> crew
CTB	: <u>C</u> ross-recessed head <u>T</u> apping screw (<u>B</u> ind screw)
RE	: <u>R</u> etaining ring Type-E

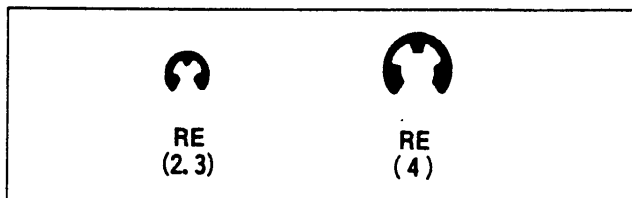

Actual Size of Small Parts

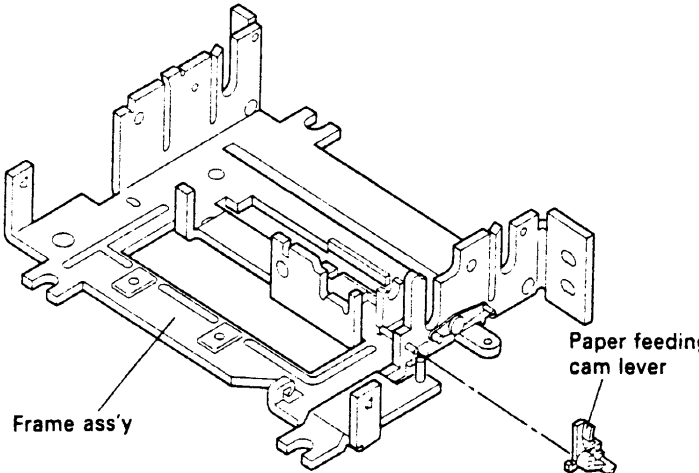
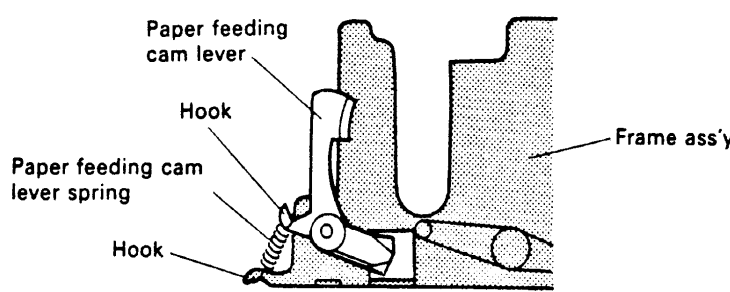
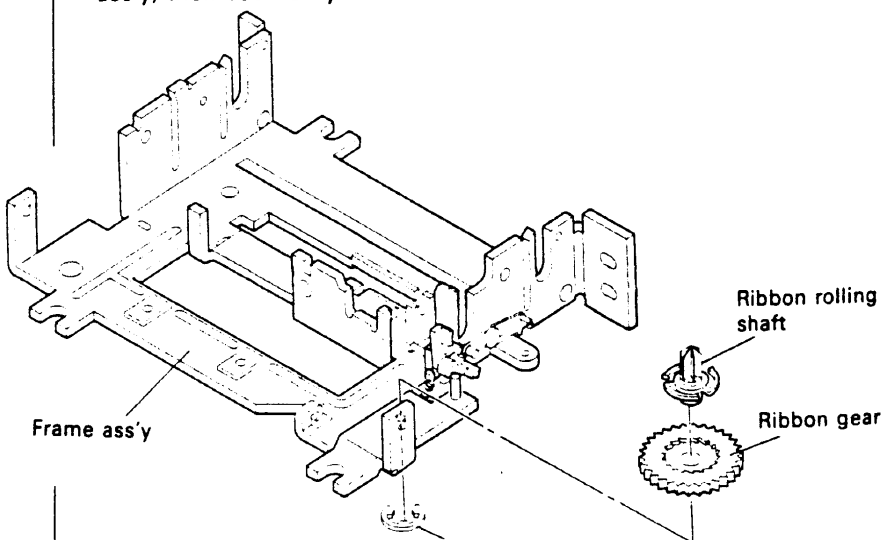

3.2.1 Subassembly

Subassembly A Frame Unit

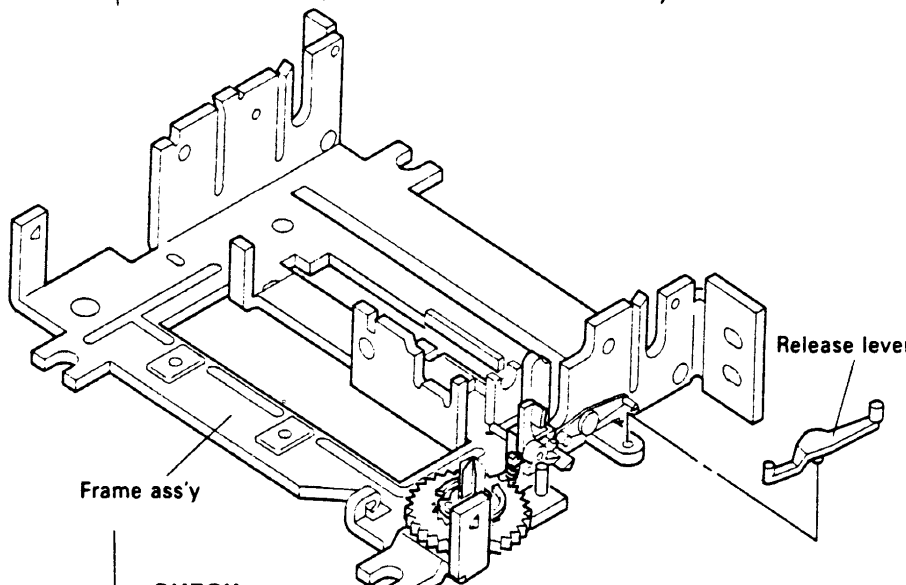
Reassembly Step	Names of Parts	Points of Reassembly Work
<p>1 ②</p>	<p>Frame ass'y Paper feeding cam lever</p>	<p>● Mount the paper feeding cam lever onto the paper feeding cam lever shaft of the frame ass'y.</p> 
<p>3</p>	<p>Paper feeding cam lever spring</p>	<p>● Attach one side of the paper feeding cam lever spring to the hook of the frame ass'y and the other side to the hook of the paper feeding cam lever.</p>  <p style="text-align: center;">< Frame G Side ></p>
<p>4</p>	<p>Ribbon gear</p>	<p>● Mount the ribbon gear and the ribbon rolling shaft into the frame ass'y, then secure by RE.</p>
<p>5</p>	<p>Ribbon rolling shaft RE (4)</p>	

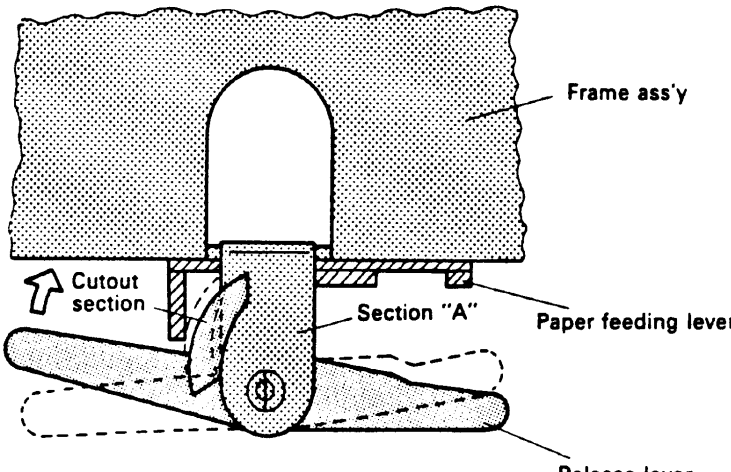
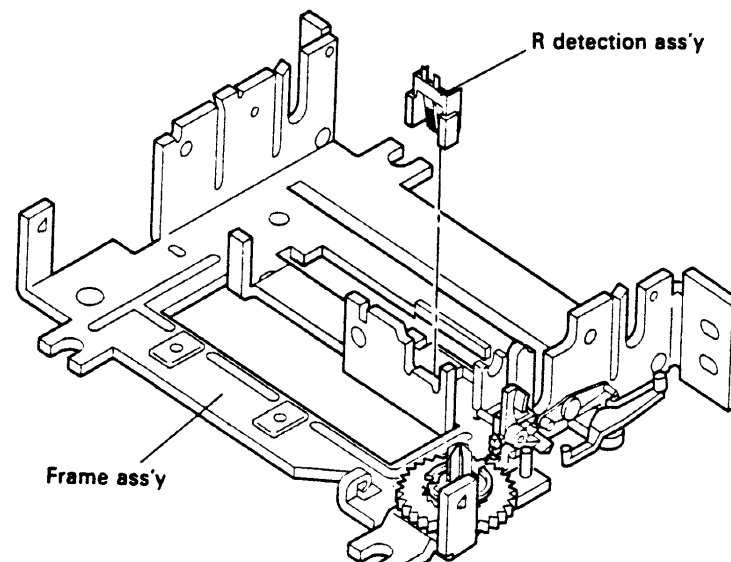

Reassembly Step	Names of Parts	Points of Reassembly Work
<p>⑥</p> <p>★</p>	<p>Release lever</p>	<p>● Mount the release lever into the frame ass'y.</p>  <p><CHECK></p> <p>● When the release lever is moved in the  arrow direction, the cutout section of the lever should smoothly catch section "A" of the frame.</p> 
<p>7</p>	<p>R detection ass'y</p>	<p>● Mount the R detection ass'y into the frame ass'y.</p> 

Reassembly Step	Names of Parts	Points of Reassembly Work
<p>8 ★</p>	<p>FPC holding spring</p>	<ul style="list-style-type: none"> ● Mount the FPC holding spring from the bottom of the frame ass'y. <CHECK> ● The two tabs on the bottom of the frame ass'y should be inserted securely into the two holes of the FPC holding spring.

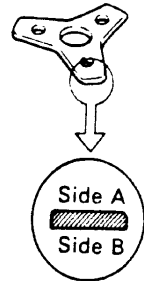
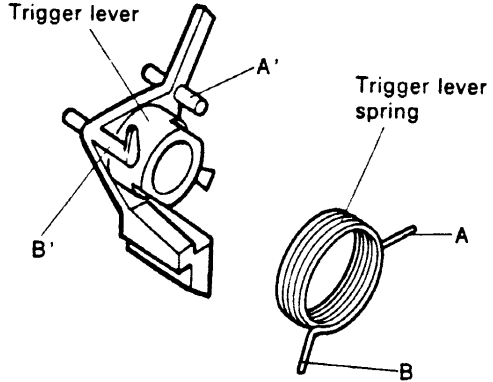
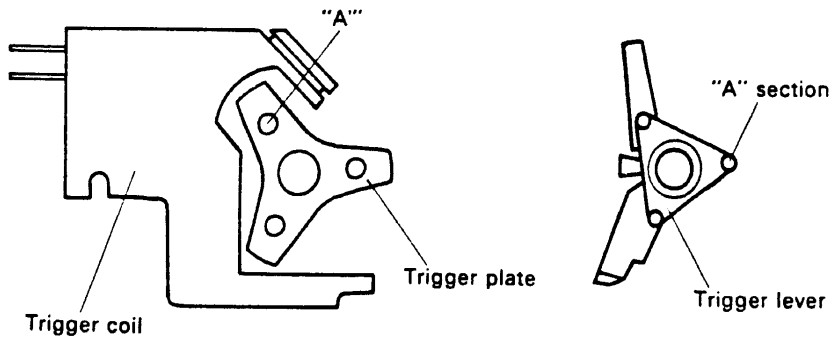
Subassembly B Carrier Driving Camshaft Unit

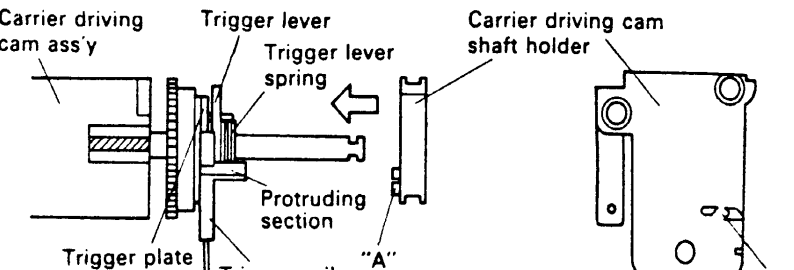
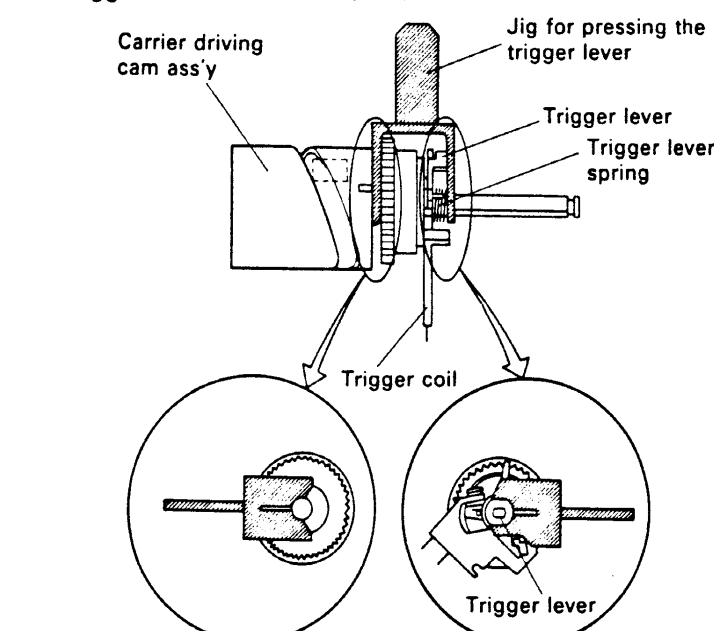
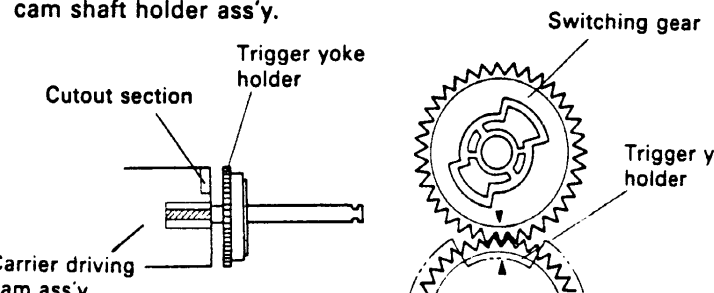
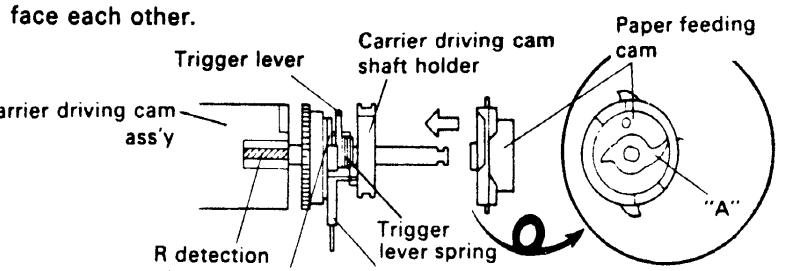
Reassembly Step	Names of Parts	Points of Reassembly Work
① 2 3	Carrier driving cam ass'y Trigger coil Trigger plate	<ul style="list-style-type: none"> ● Mount the trigger plate so its B side faces the trigger coil. 
4 5 6	Trigger plate spring Trigger lever Trigger lever spring	<ul style="list-style-type: none"> ● Hook "A" of the trigger lever spring onto "A'" of the trigger lever, and hook "B" onto "B".
		 <ul style="list-style-type: none"> ● Mount the trigger lever so that its "A" section (protruding section) enters holes "A" of the trigger plate. 
★		<p><CHECK></p> <ul style="list-style-type: none"> ● Make sure the three protruding sections of the trigger lever enter their respective holes of the trigger plate.

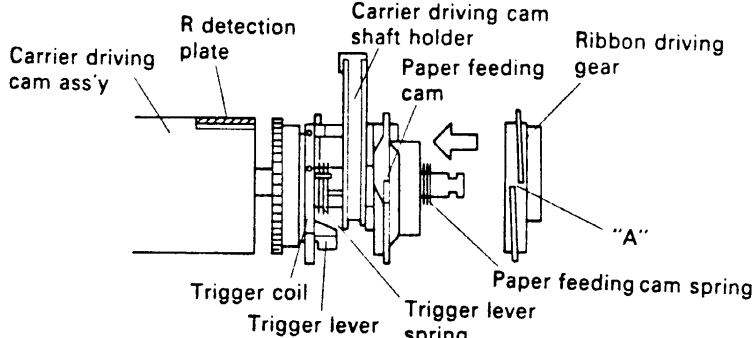
Reassembly Step	Names of Parts	Points of Reassembly Work
7	Carrier driving cam shaft holder Model-260	<ul style="list-style-type: none"> ● Mount the carrier driving cam shaft holder so that its "A" section is penetrated by the protruding section of the trigger coil. 
	Carrier driving cam shaft holder ass'y Model-262	<ul style="list-style-type: none"> ● After mounting the components of Steps 2 to 6 into the carrier driving cam ass'y, temporarily secure them using the jig for pressing the trigger lever as shown below. 
⑧	Paper feeding cam	<ul style="list-style-type: none"> ● Perform setting by matching the ▲ symbol (on the side corresponding to the cutout section of the carrier cam ass'y) of the trigger yoke holder with the ▲ symbol of the switching gear on the carrier driving cam shaft holder ass'y. 
9	Paper feeding cam spring	<ul style="list-style-type: none"> ● Mount the paper feeding cam so that the R detection plate of the carrier driving cam ass'y and section "A" of the paper feeding cam face each other. 

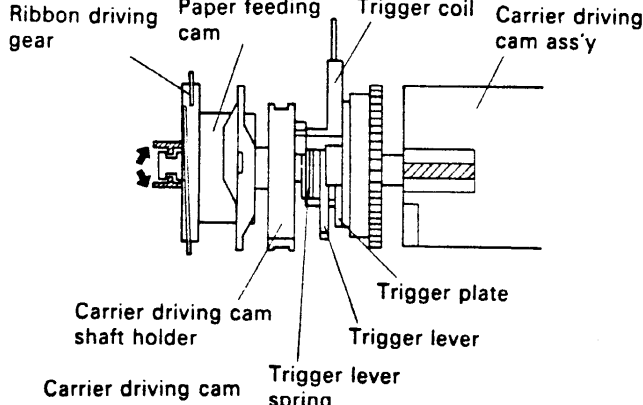
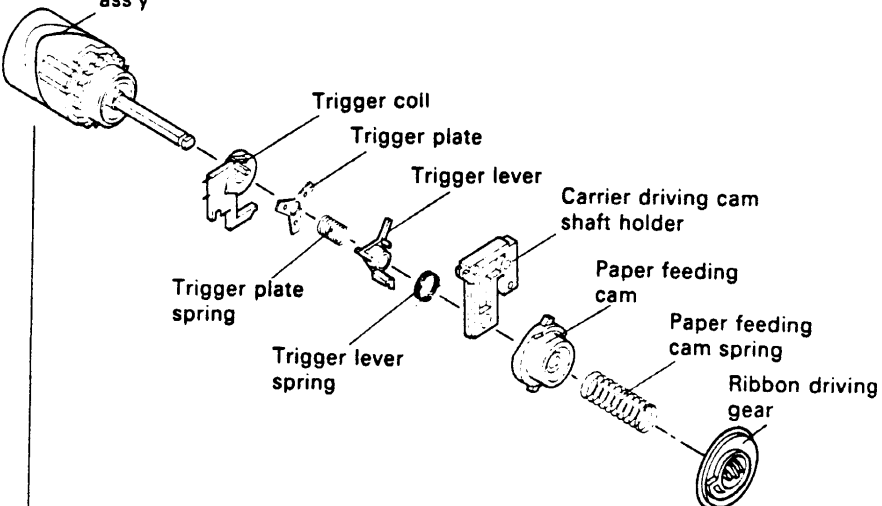
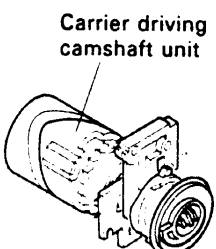
Reassembly Step	Names of Parts	Points of Reassembly Work
<p>10</p> <p>★</p> <p>★</p>	<p>Ribbon driving gear</p>	<ul style="list-style-type: none"> ● With the R detection plate of the carrier driving cam ass'y at the very top, rotate the ribbon driving gear in the counter-clockwise direction and then mount it so that its "A" section is horizontal, pressing it inward until a click is heard. <p>< CHECK ></p> <ul style="list-style-type: none"> ● The ribbon driving gear should be securely mounted.  <p>< POINT IN DISASSEMBLY ></p> <ul style="list-style-type: none"> ● Remove the ribbon driving gear while pressing its pawl section in the  arrow direction.   

3.2.2 Main Assembly

Main Assembly A Frame Unit, Carrier Driving Camshaft Unit, Reduction Unit, and Circuit Board

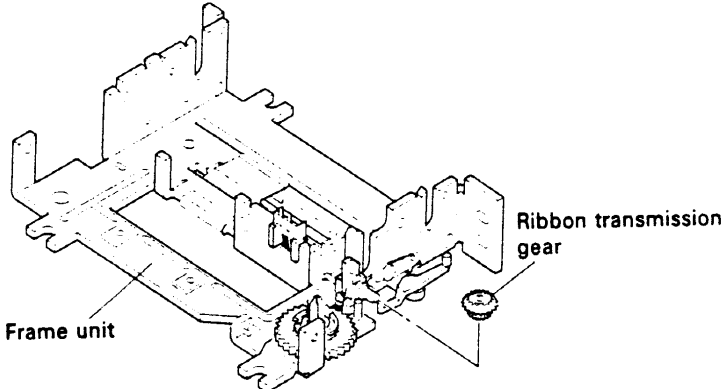
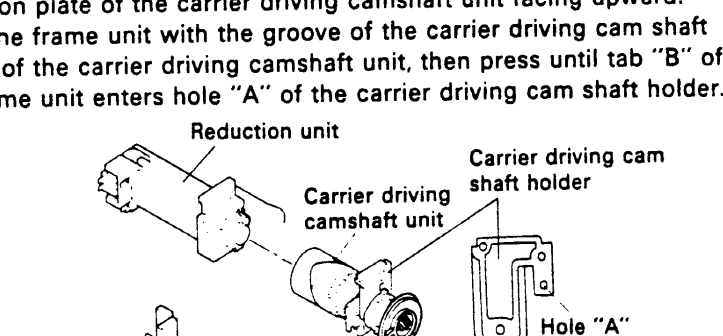
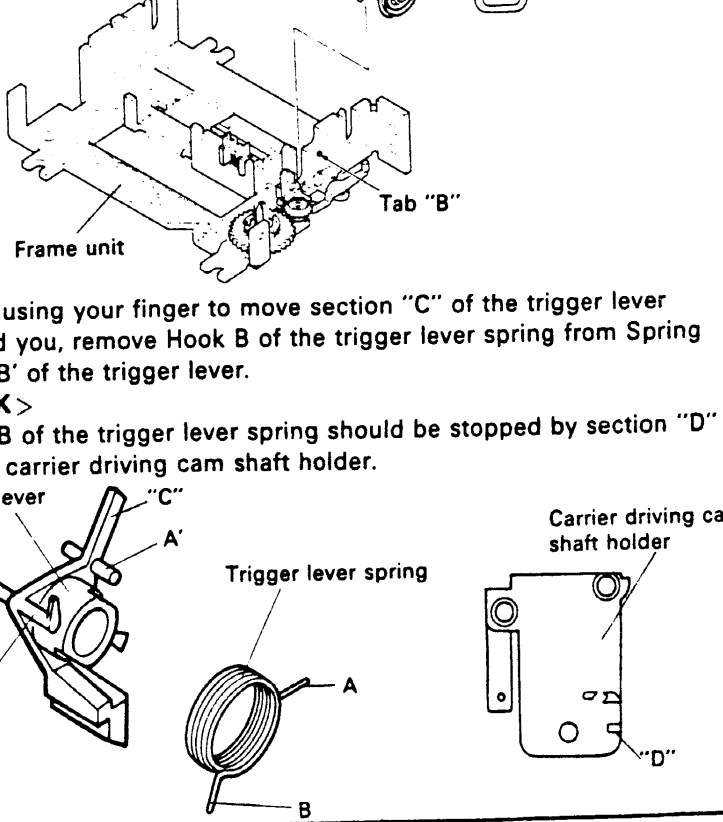
Reassembly Step	Names of Parts	Points of Reassembly Work
1	Frame unit Subassembly A	
2	Ribbon transmission gear	<ul style="list-style-type: none"> ● Mount the ribbon transmission gear onto the ribbon transmission gear shaft of the frame unit.
3	Carrier driving camshaft unit Subassembly B	
④	Reduction unit	<ul style="list-style-type: none"> ● Mount the reduction unit with its label facing upward and the R detection plate of the carrier driving camshaft unit facing upward. ● Align the frame unit with the groove of the carrier driving cam shaft holder of the carrier driving camshaft unit, then press until tab "B" of the frame unit enters hole "A" of the carrier driving cam shaft holder.
★		 <ul style="list-style-type: none"> ● While using your finger to move section "C" of the trigger lever toward you, remove Hook B of the trigger lever spring from Spring Hook B' of the trigger lever. <p><CHECK></p> <ul style="list-style-type: none"> ● Hook B of the trigger lever spring should be stopped by section "D" of the carrier driving cam shaft holder. 

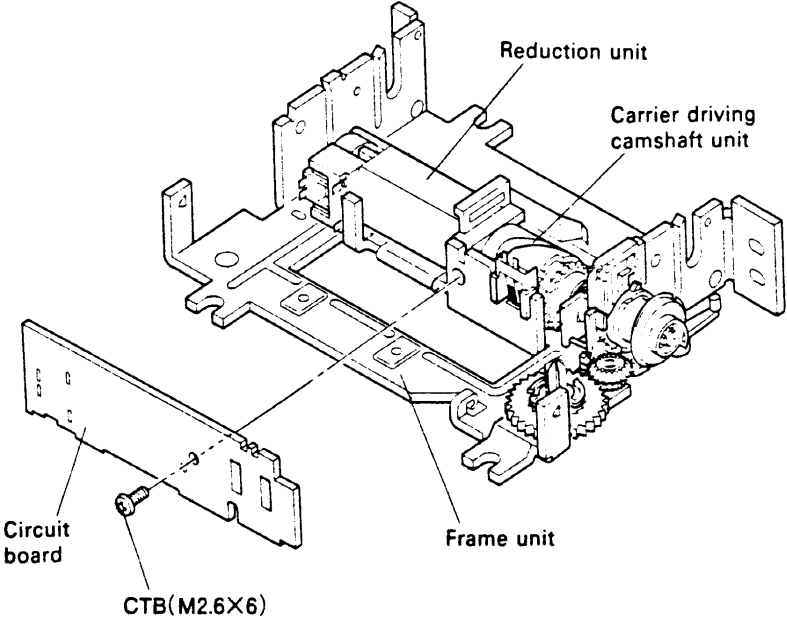
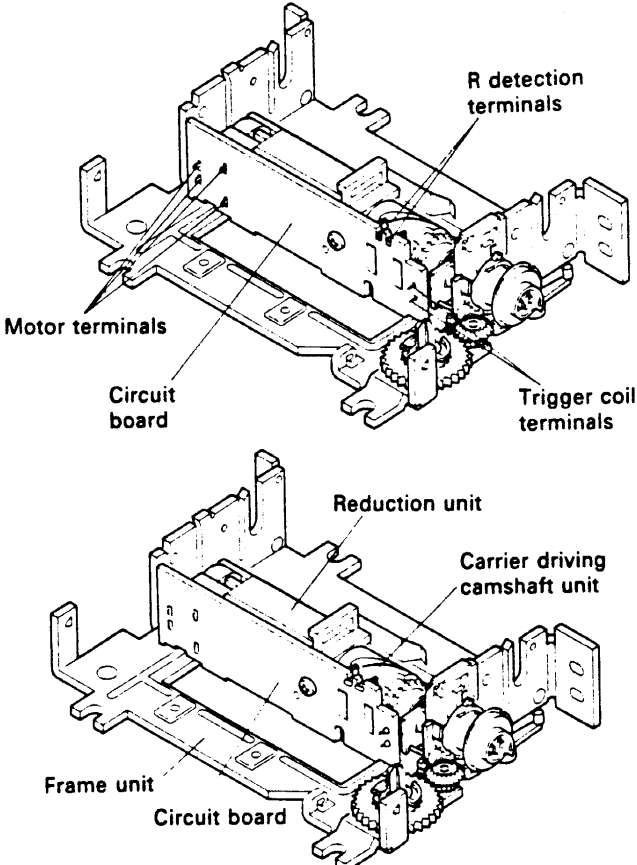
Reassembly Step	Names of Parts	Points of Reassembly Work
☆ ⑤	Circuit board CTB (M2.6×6) ×1	<p><POINT IN DISASSEMBLY></p> <ul style="list-style-type: none"> ● After removing tab "B" of the frame unit from hole "A" of the carrier driving cam shaft holder, lift up the carrier driving camshaft unit and the reduction unit. ● Mount the circuit board into the frame unit, simultaneously press down on the reduction unit and circuit board from above, then tighten the screw. 
6	Soldering	<ul style="list-style-type: none"> ● Solder the four motor terminals, two R detection terminals, and two trigger coil terminals to the circuit board. 

Main Assembly B Dot Head Unit, Guide Shaft, and Return Support Spring

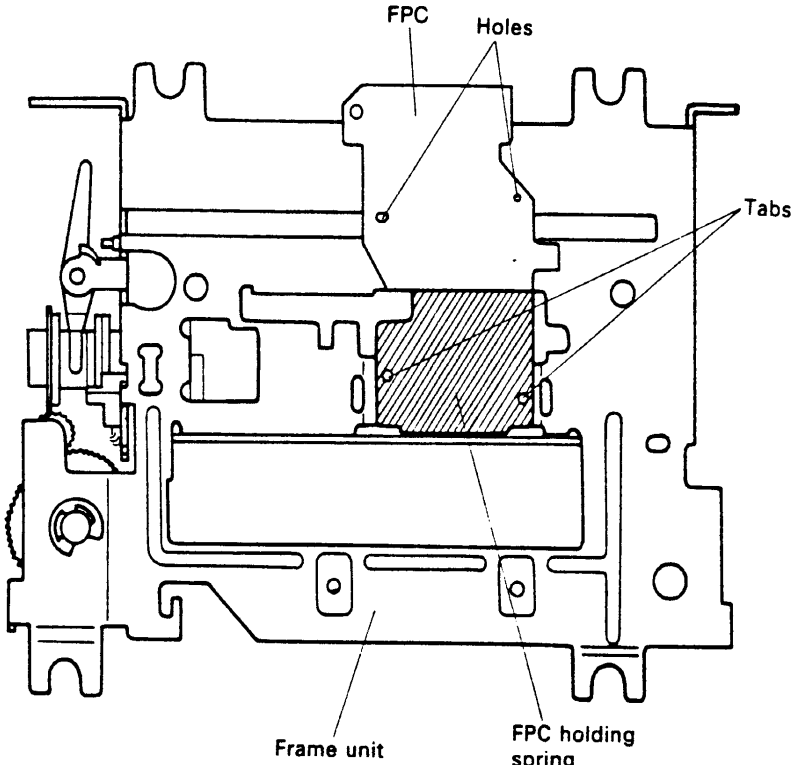
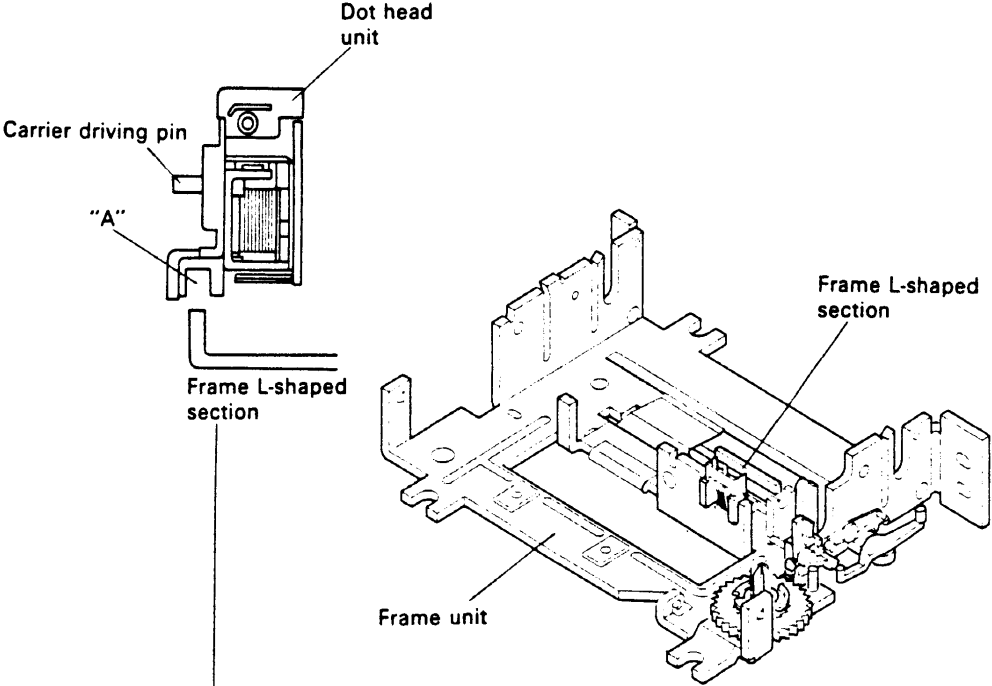
Reassembly Step	Names of Parts	Points of Reassembly Work
<p>① ★</p>	<p>Dot head unit</p>	<ul style="list-style-type: none"> ● Mount the FPC of the dot head unit beneath the FPC holding spring. <p><CHECK></p> <ul style="list-style-type: none"> ● The two holes of the FPC of the dot head unit should fit onto the tabs at the bottom of the frame unit (where the FPC holding spring is also mounted).  <ul style="list-style-type: none"> ● While inserting the carrier driving pin of the dot head unit into the cam groove of the carrier driving camshaft unit, mount section "A" of the dot head unit onto the L-shaped section of the frame unit. 

Reassembly Step	Names of Parts	Points of Reassembly Work
2	Guide shaft	<ul style="list-style-type: none"> ● Pass the guide shaft through the dot head unit from Side G of the frame unit.
3	Return support spring RE(2.3) × 1	<ul style="list-style-type: none"> ● Mount from Side M of the frame unit, then secure to the guide shaft by RE from inside the frame.

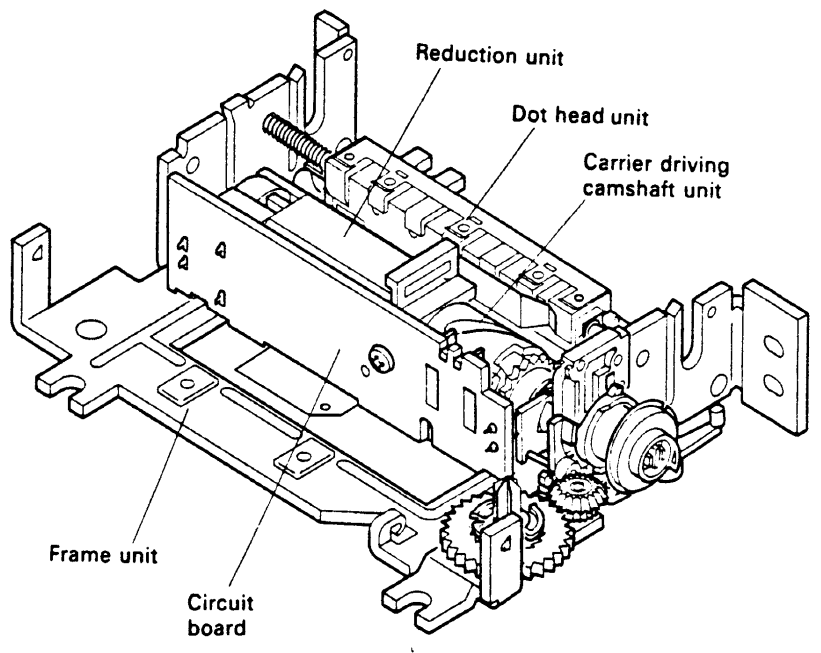
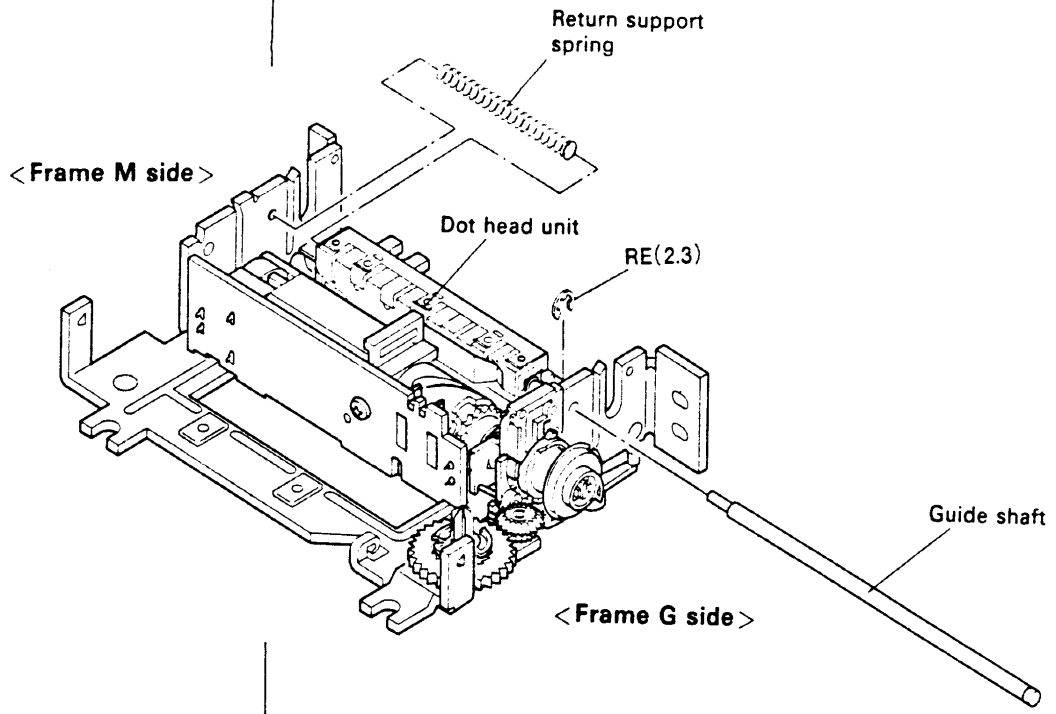

Main Assembly C Paper Guide Unit, Connector, and Connector Circuit Board

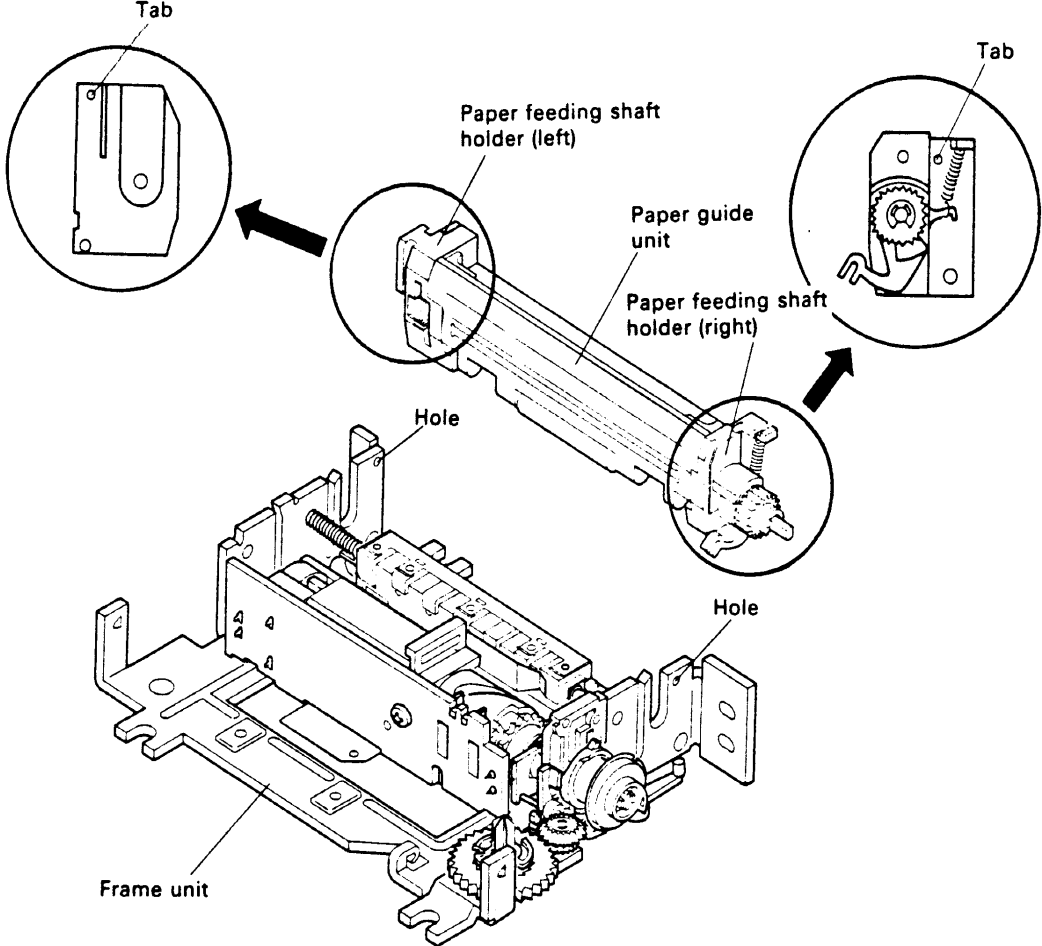
Reassembly Step	Names of Parts	Points of Reassembly Work
<p>①</p> <p>★</p>	<p>Paper guide unit</p>	<ul style="list-style-type: none"> ● Mount the paper guide unit by aligning the frame unit with the grooves on the right and left paper feeding shaft holders. <p><CHECK></p> <ul style="list-style-type: none"> ● Make sure that the two tabs of the right and left paper feeding shaft holders are inserted into the holes of the frame unit.
<p>☆</p>		 <p><POINT IN DISASSEMBLY></p> <ul style="list-style-type: none"> ● Remove the tabs of the right and left paper feeding shaft holders, then remove the right and left paper feeding shaft holders by using tweezers to lift them up and out of the frame unit.

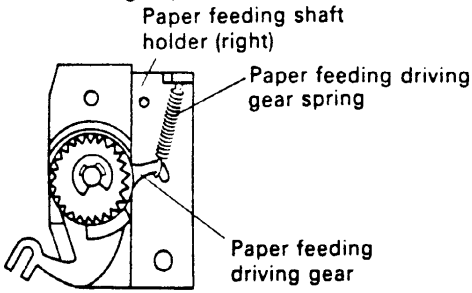
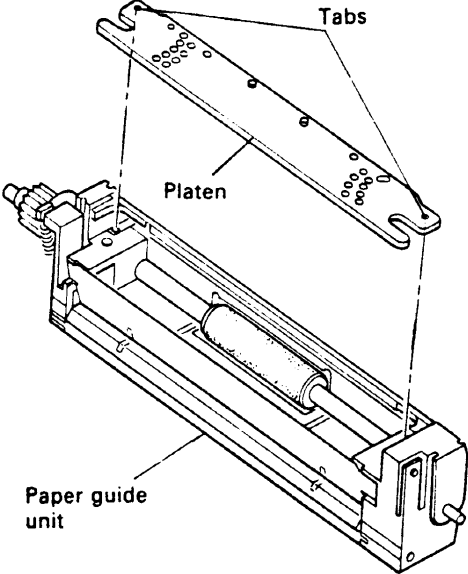
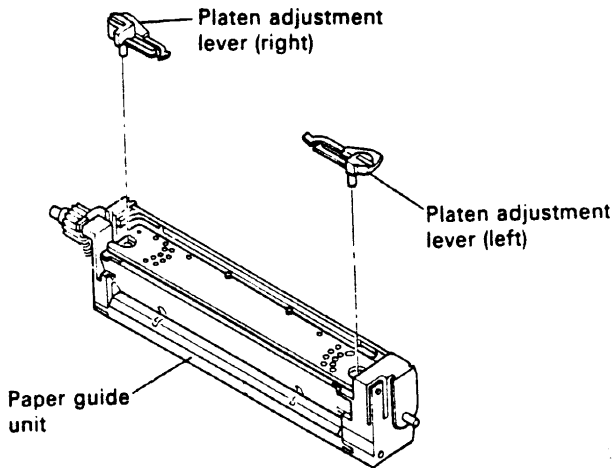
Reassembly Step	Names of Parts	Points of Reassembly Work
◎ ☆	(Paper feeding driving gear spring)	<ul style="list-style-type: none"> ● Mount the spring by first hooking one side to the right paper feeding shaft holder, then hooking the other side to the paper feeding driving gear. <p>< POINT IN DISASSEMBLY ></p> <ul style="list-style-type: none"> ● After disconnecting the spring from the paper feeding driving gear, disconnect it from the right paper feeding shaft holder .  <p>Paper feeding shaft holder (right) Paper feeding driving gear spring Paper feeding driving gear</p>
◎	(Platen)	<ul style="list-style-type: none"> ● Insert the two tabs of the platen into the holes of the inner paper guide of the paper guide unit.  <p>Platen Paper guide unit Tabs</p>
☆ ☆		<ul style="list-style-type: none"> ● Mount the right and left platen adjustment levers. <p>< POINT IN DISASSEMBLY ></p> <ul style="list-style-type: none"> ● Remove the right and left platen adjustment levers from the paper guide unit, then remove the platen. <p>< ADJUSTMENT ></p> <ul style="list-style-type: none"> ● Platen Gap Adjustment (See ADJUSTMENT A of section 3.3, "ADJUSTMENTS.")  <p>Platen adjustment lever (right) Platen adjustment lever (left) Paper guide unit</p>

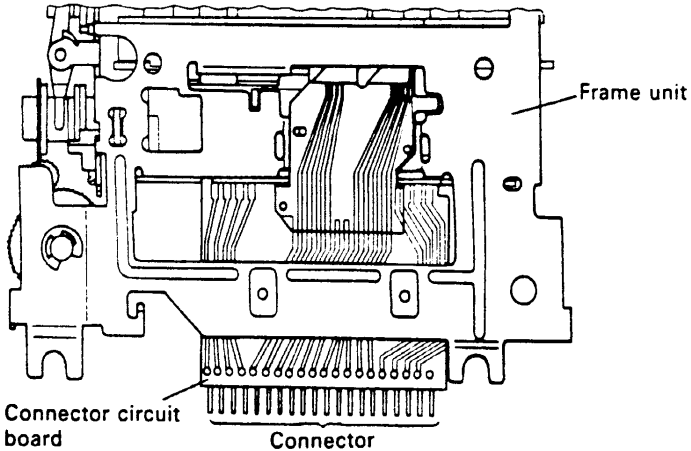
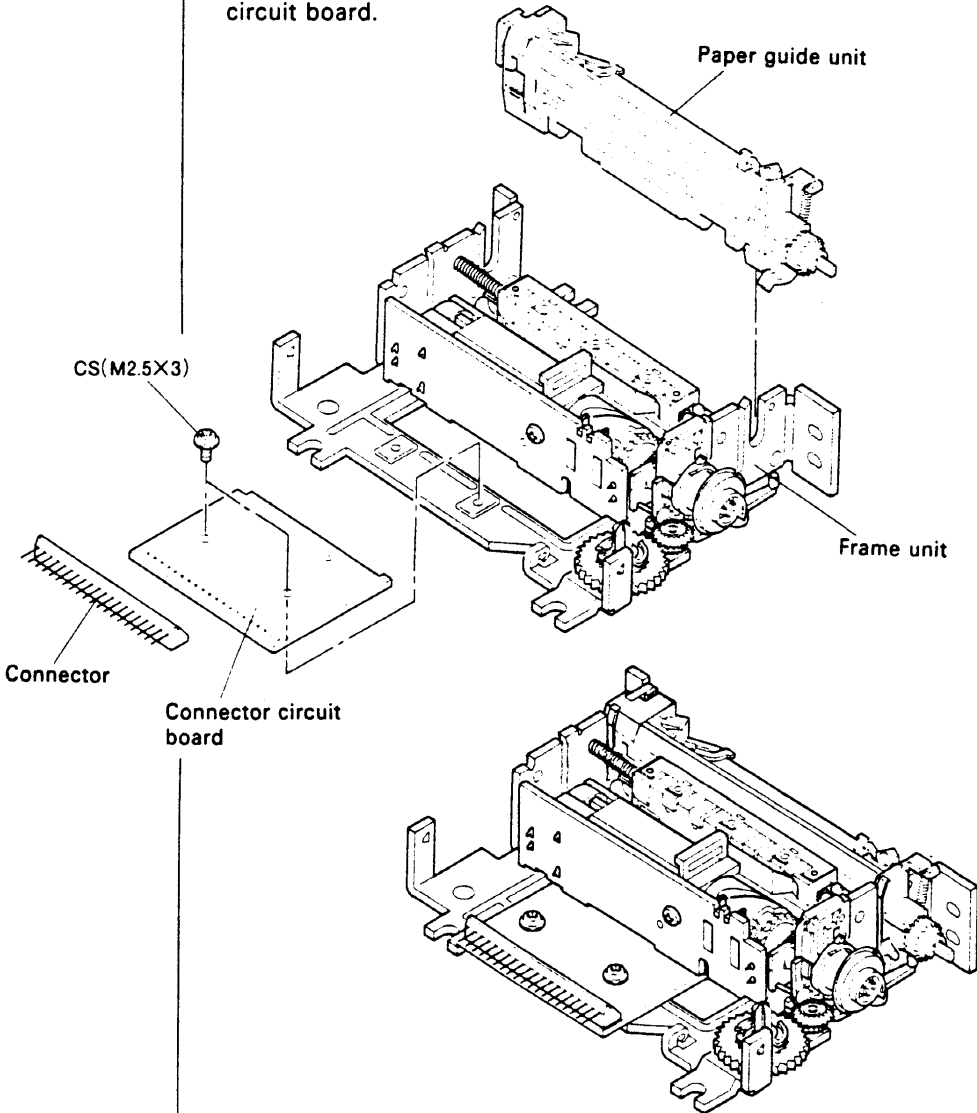
Reassembly Step	Names of Parts	Points of Reassembly Work
2 3 ★	Connector Connector circuit board	<ul style="list-style-type: none"> ● Solder the connector to the connector circuit board . <p>< CHECK ></p> <ul style="list-style-type: none"> ● The connector should not be loose. 
★	CS(M2.5×3) ×2	<ul style="list-style-type: none"> ● Mount the connector circuit board into the frame unit, then tighten the screws. <p>< CHECK ></p> <ul style="list-style-type: none"> ● There should be no gap between the connector circuit board and the circuit board. 

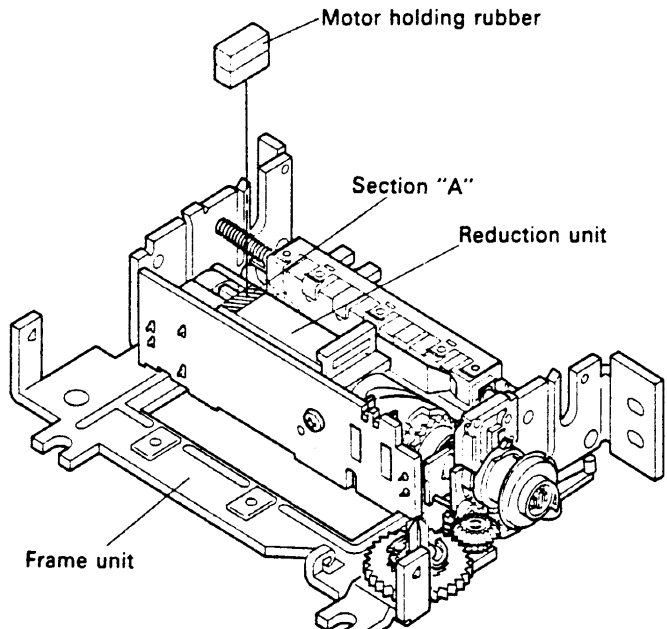
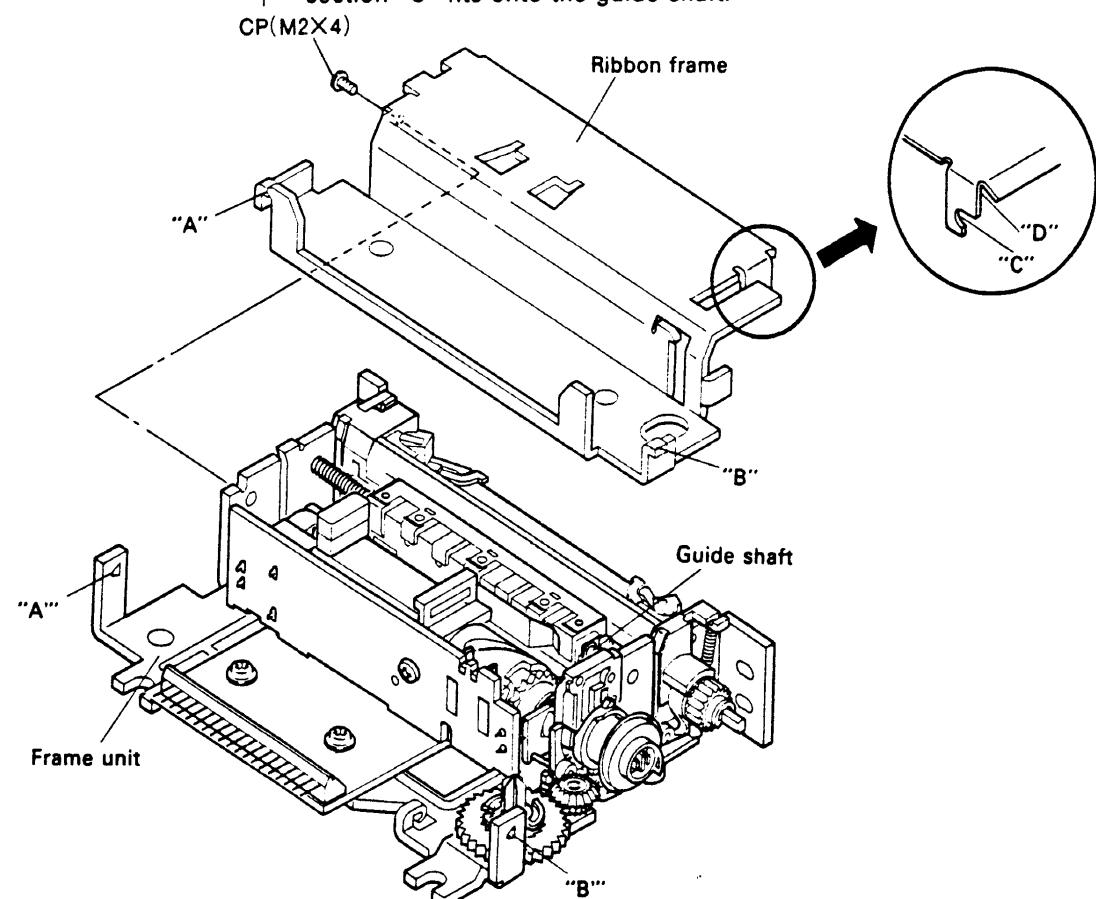
Reassembly Step	Names of Parts	Points of Reassembly Work
1	Motor holding rubber	<p>● Prior to mounting the motor holding rubber into section "A" of the reduction unit, apply double-sided tape to the motor holding rubber.</p>  <p>Motor holding rubber Section "A" Reduction unit Frame unit</p>
2	<p>Ribbon frame CP(M2×4) ×1</p>	<p>● Mount sections "A" and "B" of the ribbon frame into sections "A" and "B" of the frame unit, then press the ribbon frame until its section "C" fits onto the guide shaft.</p>  <p>CP(M2×4) Ribbon frame "A" "B" Guide shaft "A" Frame unit "B"</p> <p>☆</p> <p>< POINT IN DISASSEMBLY > ● Remove section "D" of the ribbon frame by lifting it up by tweezers.</p>

Reassembly Step	Names of Parts	Points of Reassembly Work
<p>1</p> <p>2</p>	<p>Motor holding rubber</p> <p>Cover CP(M2×4) ×1</p>	<ul style="list-style-type: none"> ● See Model-260 ● Mount section "A" of the cover onto the guide shaft, then tighten the screw.
<p>3</p>	<p>Clutch cover</p>	<ul style="list-style-type: none"> ● Align the frame unit with the groove of the clutch cover, then mount the clutch cover so that its "A" section fits into shaft "B" of the carrier driving cam shaft holder ass'y.

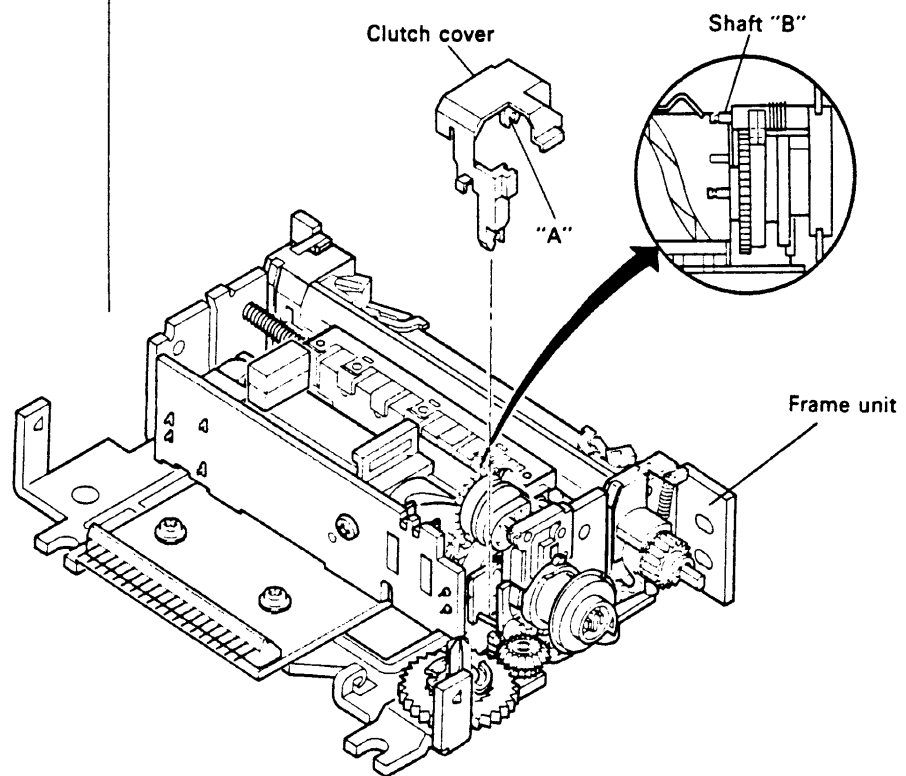
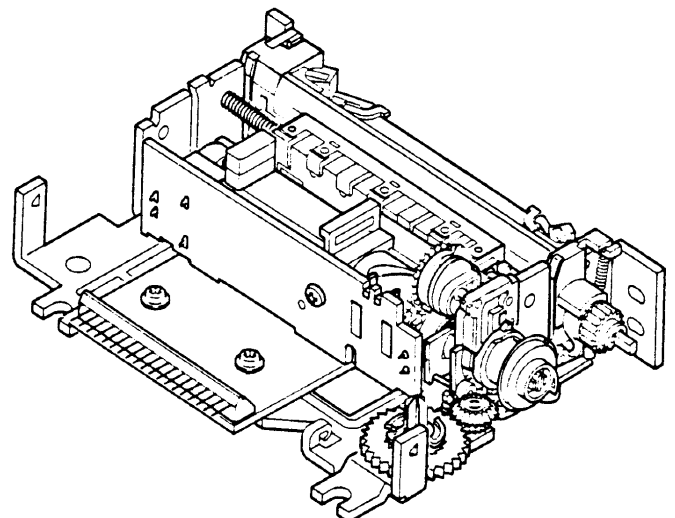
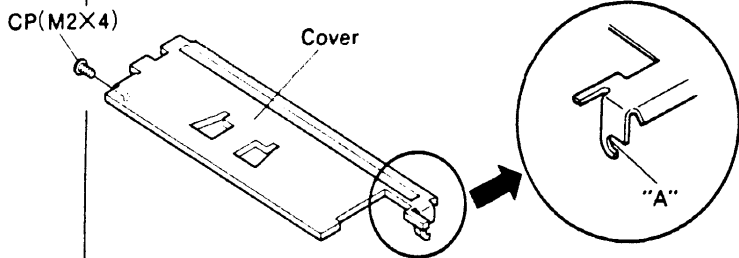

Reassembly Step	Names of Parts	Points of Reassembly Work
-----------------	----------------	---------------------------

4 Ribbon frame ● Mount sections "A" and "B" of the ribbon frame into sections "A" and "B" of the frame unit.

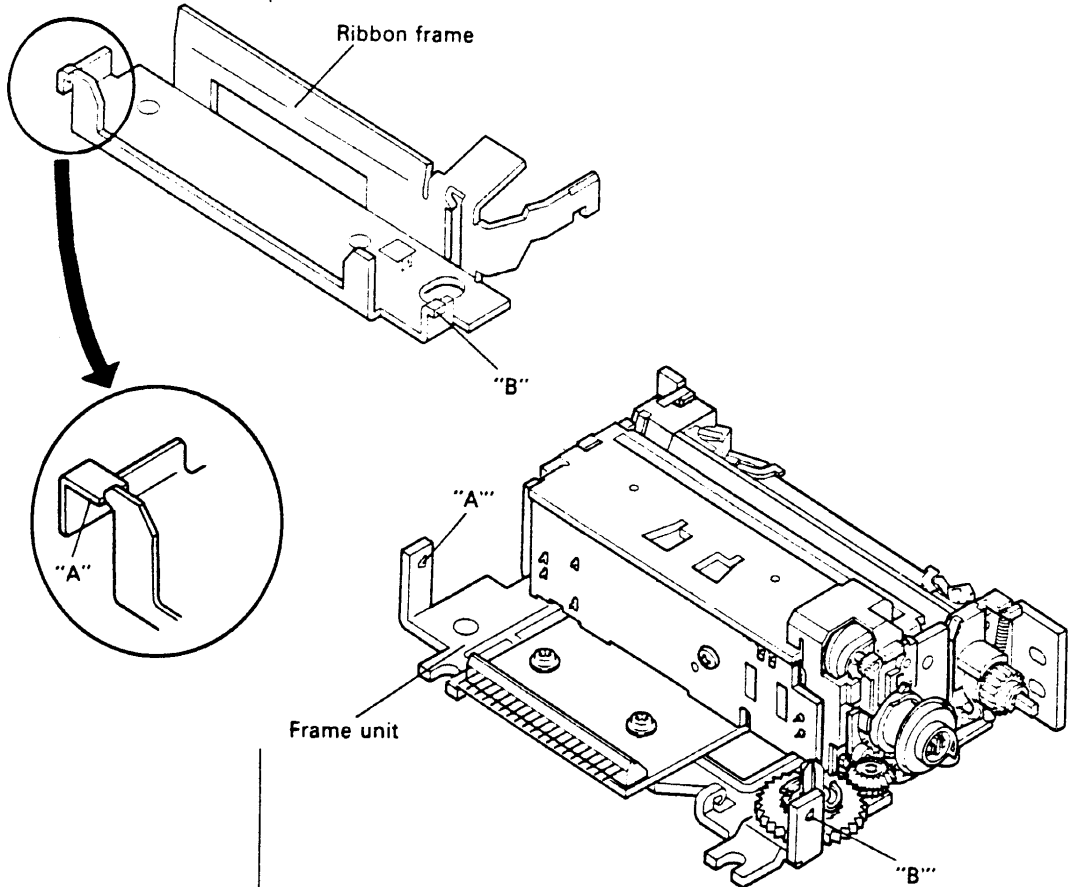

5 Ribbon frame spring ● Attach the spring onto hook "A" of the frame unit and hook "B" of the ribbon frame.

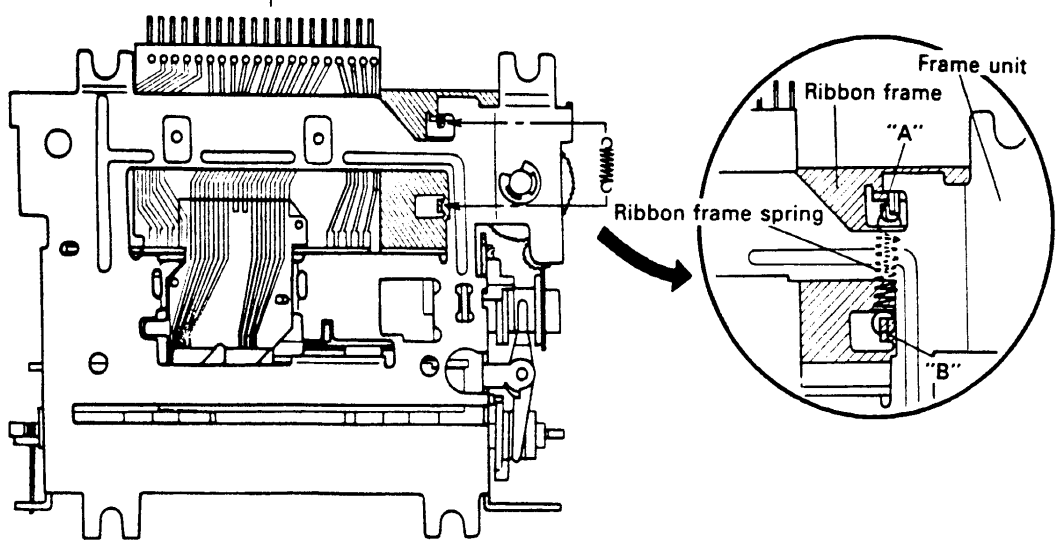



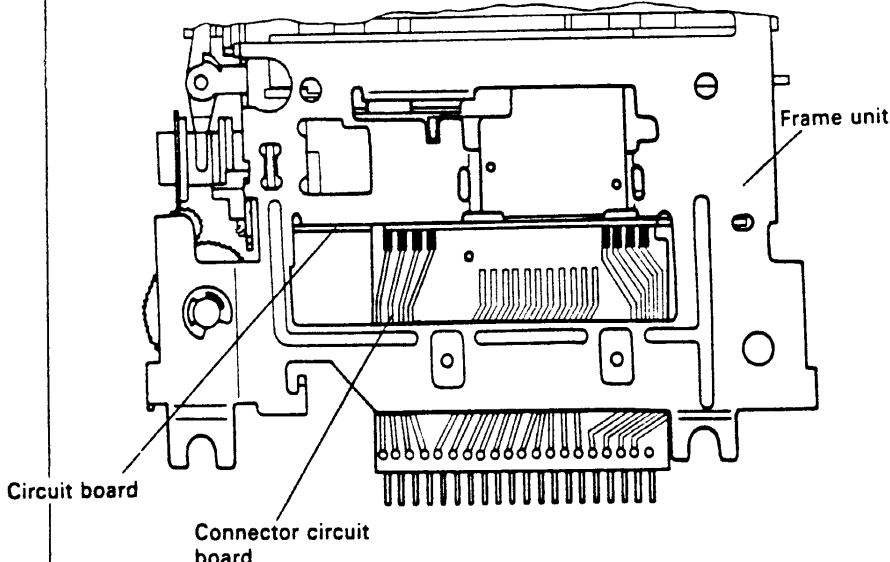
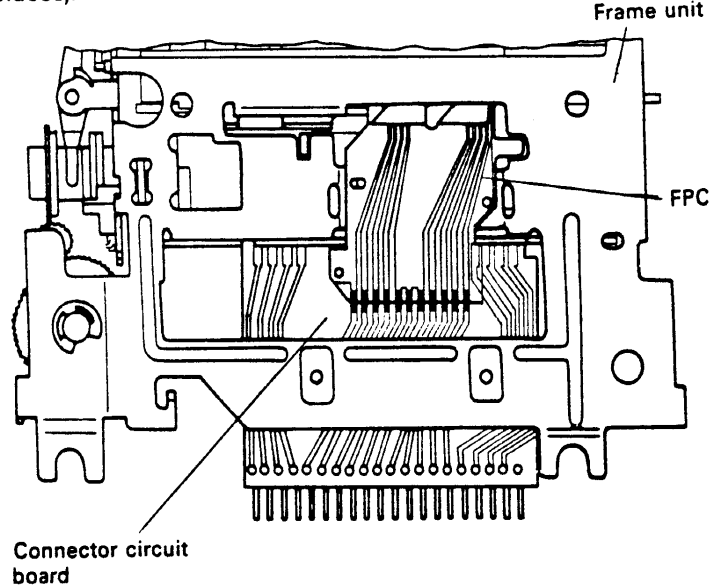

Main Assembly E Soldering

Reassembly Step	Names of Parts	Points of Reassembly Work
<p>1</p> <p>2</p>	<p>Connector circuit board</p> <p>Circuit board</p>	<p>● Solder the circuit board onto the connector circuit board (in eight places).</p> 
<p>3</p>	<p>Dot head unit</p>	<p>● Solder the FPC of the dot head unit to the connector circuit board (in 11 places).</p> 
<p>★</p>		<p>< CHECK ></p> <p>● The tab at the bottom of the frame should be inserted into the position alignment hole of FPC of the dot head unit.</p>

3.3 ADJUSTMENTS

- While assembling this printer, be sure to refer to the procedure described below in ADJUSTMENT A when required.
- After disassembly or replacement of a component during maintenance or repair, be sure to perform the required adjustment to ensure proper operation of the printer.

ADJUSTMENT A Platen Gap Adjustment

Adjustment Step	Description	Points in Adjusting
<p>1</p> <p>2</p>	<ul style="list-style-type: none"> ● Rotate the ribbon driving gear in the counter-clockwise direction to move the dot head unit to the center of the frame unit. ● Mount sections "A" of the right and left platen adjustment levers (of the paper guide unit) into adjustment holes "a" of the platen. 	<ul style="list-style-type: none"> ● While lifting up sections "A" and "B" of the platen adjustment levers by tweezers, insert a flat screwdriver into the groove of each adjustment lever and then turn it in the  arrow direction.
<p>3</p>	<ul style="list-style-type: none"> ● Insert the clearance gauge between the dot head unit and the platen, then adjust the gap. 	<ul style="list-style-type: none"> ● Either section "A" or "B" of the platen adjustment lever should be mounted in the adjustment hole of the platen. ● Rated gap: 0.6 ± 0.05 mm ● If the gap is larger than the rated value, adjust the gap by moving the platen adjustment levers in the  arrow  direction. If the gap is less than the rated value, adjust it by moving the platen adjustment levers in the  arrow  direction. Next, mount either "A" or "B" of the platen adjustment levers into the adjustment hole of the platen.
<p>4</p>	<ul style="list-style-type: none"> ● Confirm that the gap is within the rated values. 	<ul style="list-style-type: none"> ● If the gap is no within the rated values, repeat Step 3 above once more.

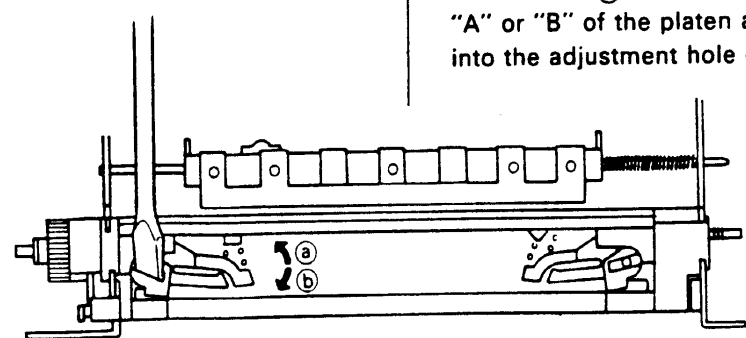
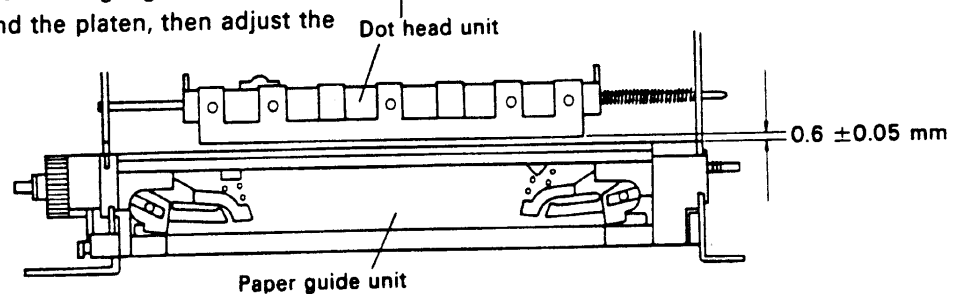
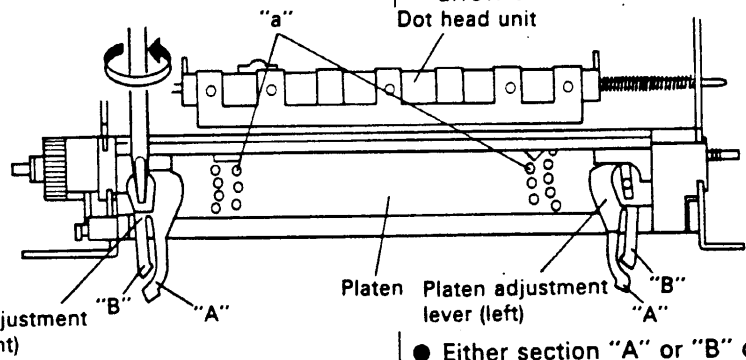

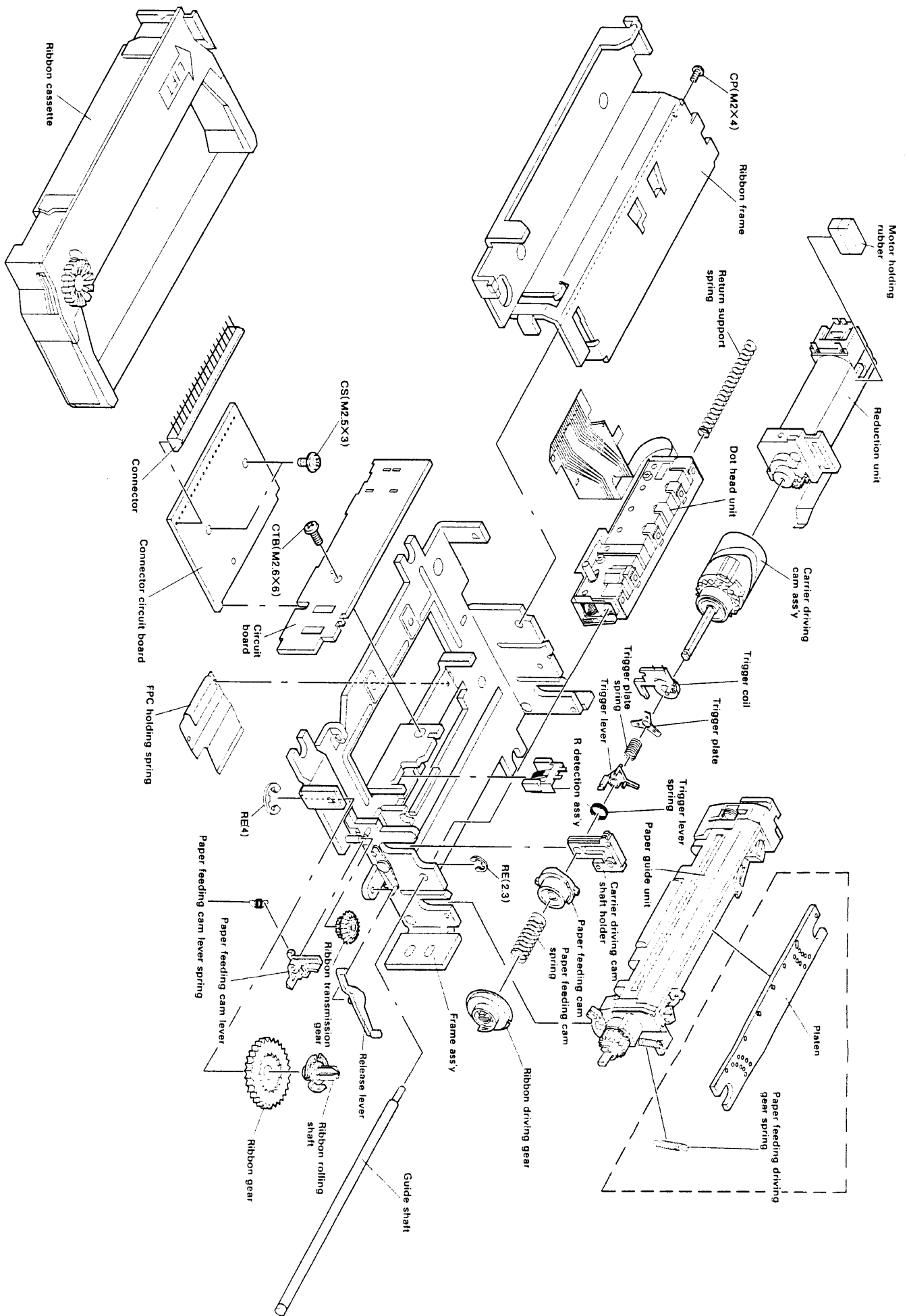

Fig. 3-1. Exploded View of Model 280

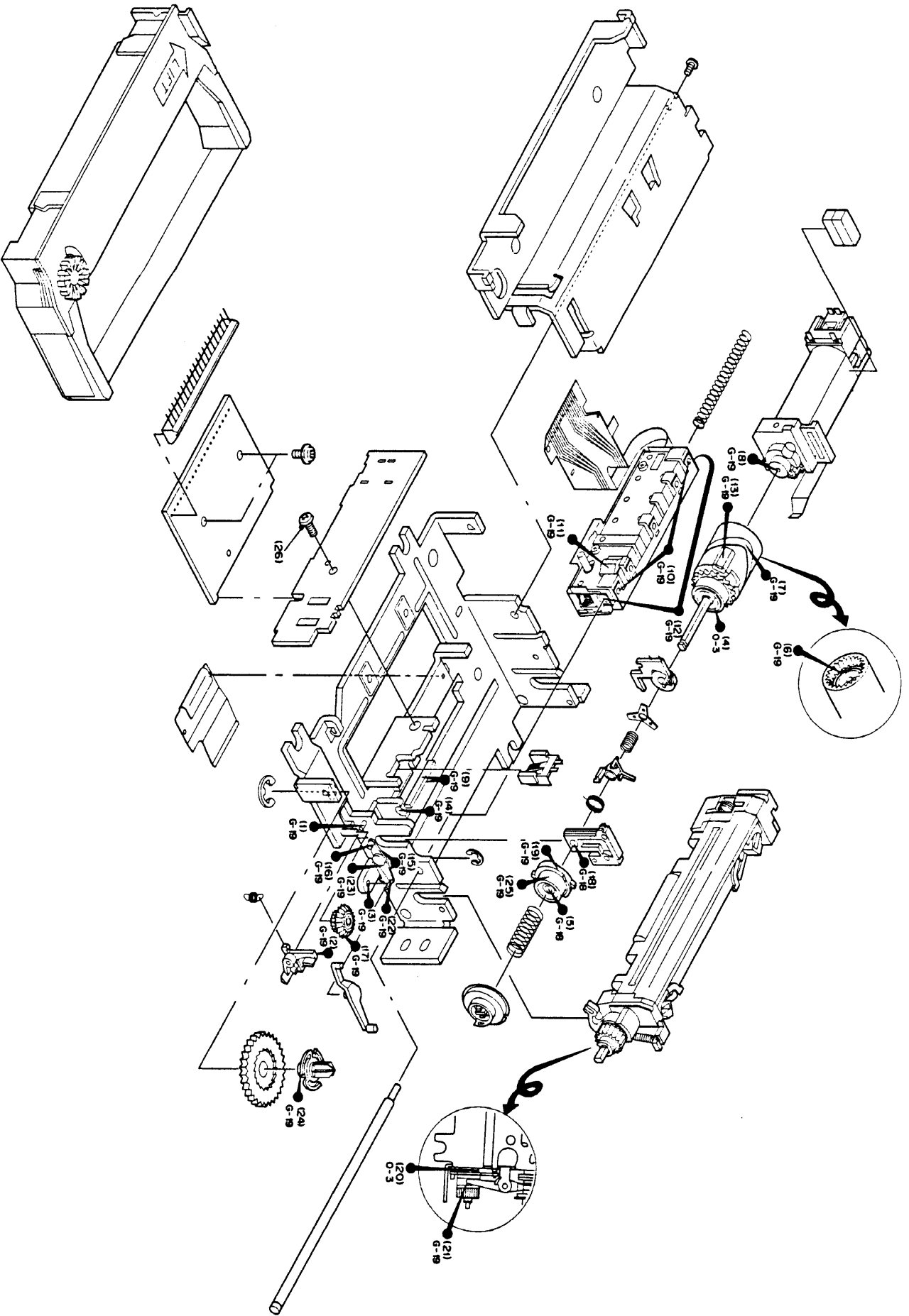

Fig. 3-2 Lubrication and Adhesive Application Points of Model 260

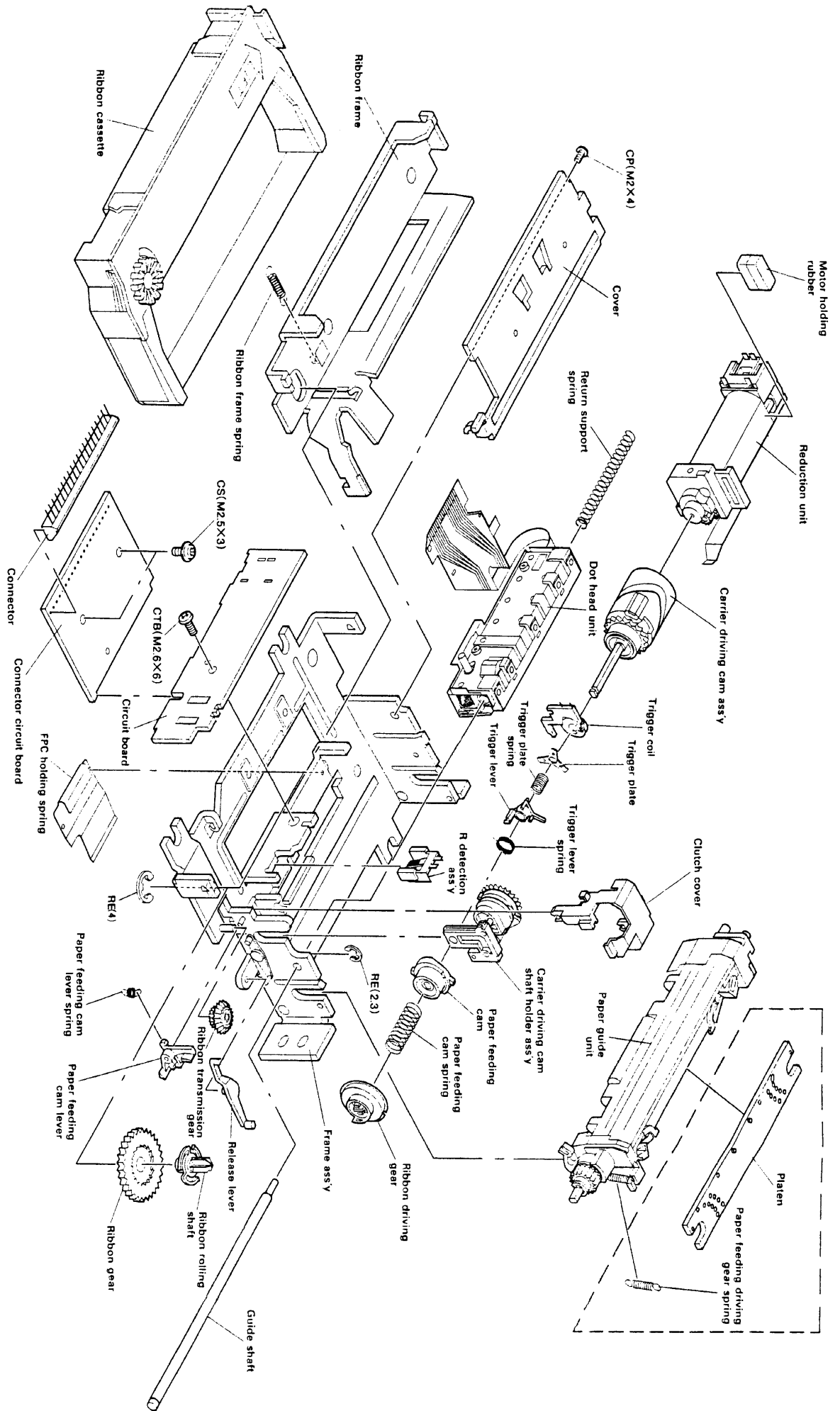

Fig. 3.3. Exploded View of Model 282

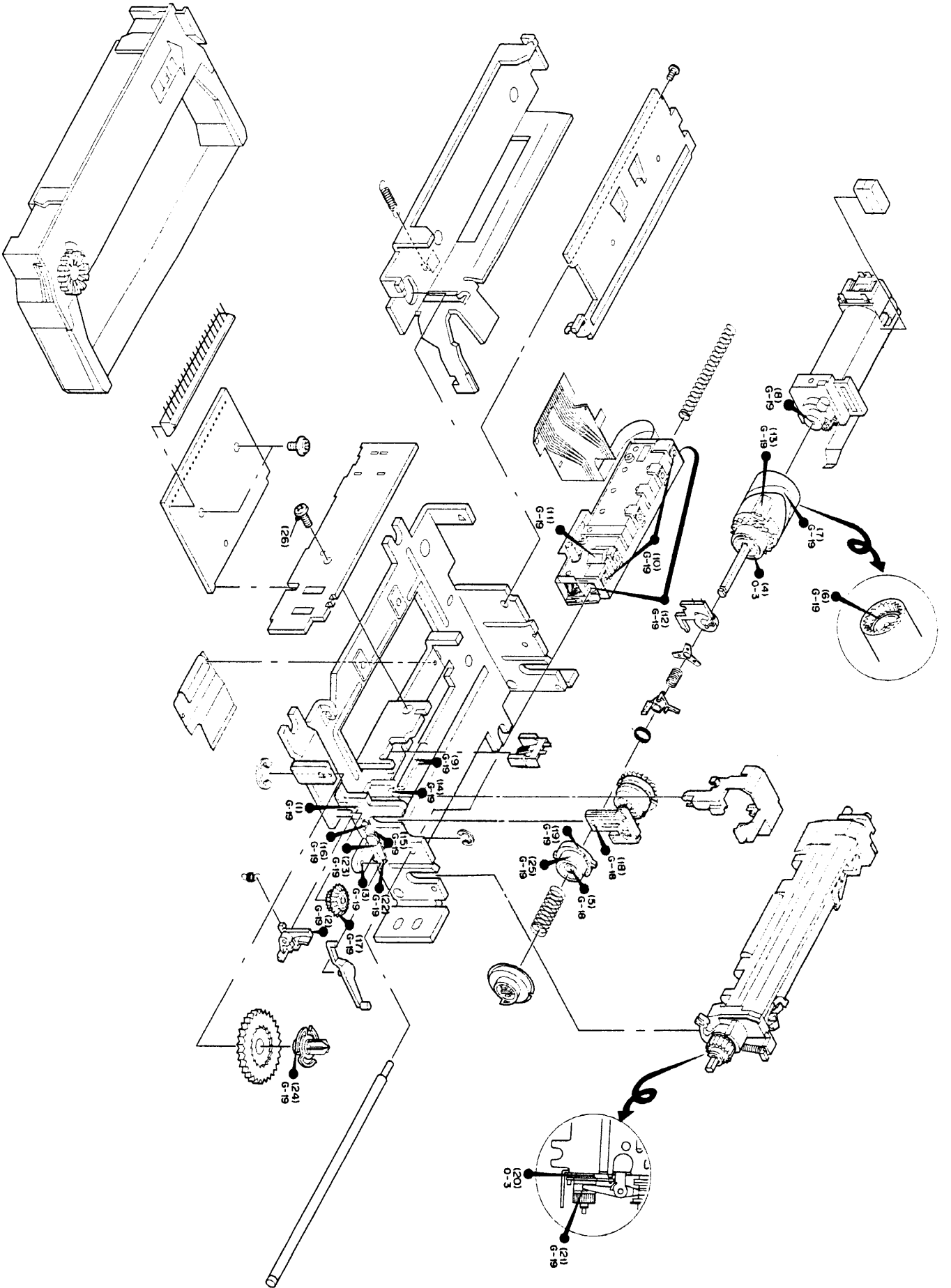

Fig. 3-4 Lubrication and Adhesive Application Points of FA Model 262