

## Low Power Quad Voltage Comparator

- Wide single supply voltage range or dual supplies for all devices: +2V to +36V or  $\pm 1V$  to  $\pm 18V$
- Very low supply current (1.1mA) independent of supply voltage (1.4mW/comparator at +5V)
- Low input bias current: 25nA typ.
- Low input offset current:  $\pm 5nA$  typ.
- Input common-mode voltage range includes ground
- Low output saturation voltage: 250mV typ. ( $I_O = 4mA$ )
- Differential input voltage range equal to the supply voltage
- TTL, DTL, ECL, MOS, CMOS compatible outputs

### Description

This device consists of four independent precision voltage comparators. All these comparators were designed specifically to operate from a single supply over a wide range of voltages. Operation from split power supplies is also possible.

These comparators also have a unique characteristic in that the input common-mode voltage range includes ground even though operated from a single power supply voltage.

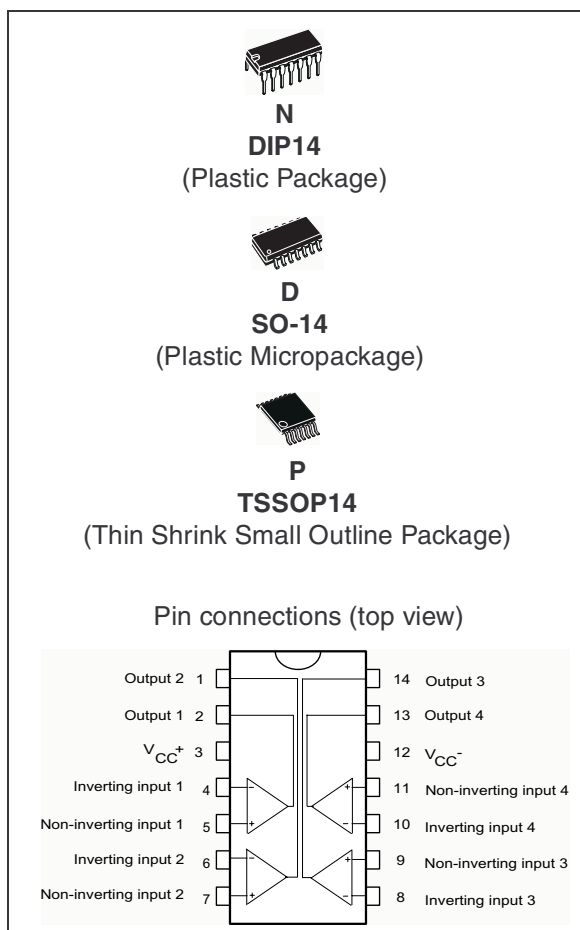

### Order Codes

Part Number	Temperature Range	Package	Packing	Marking
LM2901N	-40°C, +125°C	DIP14	Tube	LM2901N
LM2901D/LM2901DT		SO-14	Tube or Tape & Reel	2901
LM2901PT		TSSOP14 (Thin Shrink Outline Package)	Tape & Reel	
LM2901YD/YDT		SO-14 (automotive grade level)	Tube or Tape & Reel	2901Y
LM2901YPT		TSSOP14 (automotive grade level)	Tape & Reel	

# 1 Absolute Maximum Ratings

**Table 1. Key parameters and their absolute maximum ratings**

Symbol	Parameter	Value	Unit
$V_{CC}$	Supply Voltage	$\pm 18$ to 36	V
$V_{ID}$	Differential Input Voltage	$\pm 36$	V
$V_I$	Input Voltage	-0.3 to +36	V
	Output Short-circuit to Ground <sup>(1)</sup>		
$P_d$	Power Dissipation <sup>(2)</sup>		mW
	DIP14	1500	
	SO-14	830	
	TSSOP14	710	
$T_J$	Junction Temperature	+150	°C
$T_{stg}$	Storage Temperature Range	-65 to +150	°C
ESD	HBM: Human Body Model <sup>(3)</sup>	1.5	Kv
	MM: Machine Model <sup>(4)</sup>	100	V
	CDM: Charged Device Model	1500	V

1. Short-circuit from the output to  $V_{CC}^+$  can cause excessive heating and eventual destruction. The maximum output current is approximately 20mA, independent of the magnitude of  $V_{CC}^+$ .
2.  $P_d$  is calculated with  $T_{amb} = +25^\circ\text{C}$ ,  $T_J = +150^\circ\text{C}$  and  
 $R_{thja} = 80^\circ\text{C/W}$  for DIP14 package  
 $R_{thja} = 150^\circ\text{C/W}$  for SO-14 package  
 $R_{thja} = 175^\circ\text{C/W}$  for TSSOP14 package
3. Human body model, 100pF discharged through a 1.5k $\Omega$  resistor into pin of device.
4. Machine model ESD, a 200pF cap is charged to the specified voltage, then discharged directly into the IC with no external series resistor (internal resistor < 5 $\Omega$ ), into pin to pin of device.

**Table 2. Operating conditions**

Symbol	Parameter	Value	Unit
$V_{CC}$	Supply Voltage	2 to 32 $\pm 1$ to $\pm 16$	V
$V_{icm}$	Common Mode Input Voltage Range	0 to ( $V_{CC}^+ - 1.5$ )	V
$T_{oper}$	Operating Free-Air Temperature range	-40 to +125	°C

## 2 Typical Application Schematics

Figure 1. Schematic diagram (1/4 LM2901)

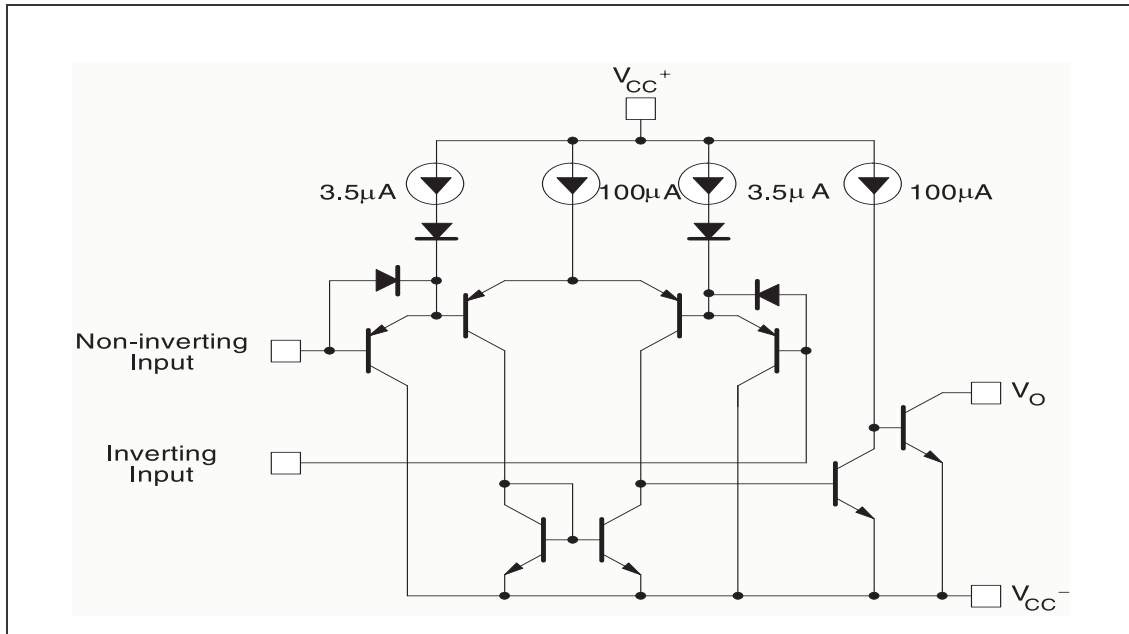

### 3 Electrical Characteristics

Table 3.  $V_{CC}^+ = 5V$ ,  $V_{CC}^- = GND$ ,  $T_{amb} = 25^\circ C$  (unless otherwise specified)

Symbol	Parameter	Min.	Typ.	Max.	Unit
$V_{io}$	Input Offset Voltage <sup>(1)</sup> $T_{amb} = +25^\circ C$ $T_{min} \leq T_{amb} \leq T_{max}$ .		1	7 15	mV
$I_{io}$	Input Offset Current $T_{amb} = +25^\circ C$ $T_{min} \leq T_{amb} \leq T_{max}$ .		5	50 150	nA
$I_{ib}$	Input Bias Current ( $I_{I^+}$ or $I_{I^-}$ ) <sup>(2)</sup> $T_{amb} = 2.5V$ $T_{min} \leq T_{amb} \leq T_{max}$ .		25	250 400	nA
$A_{vd}$	Large Signal Voltage Gain ( $V_{CC} = 15V, R_L = 15k\Omega, V_O = 1$ to $11V$ )	25	200		V/mV
$I_{CC}$	Supply Current (all comparators) $V_{CC} = +5V$ , no load $V_{CC} = +30V$ , no load		1.1 1.3	2 2.5	mA
$V_{icm}$	Input Common Mode Voltage Range ( $V_{CC} = 30V$ ) <sup>(3)</sup> $T_{amb} = +25^\circ C$ $T_{min} \leq T_{amb} \leq T_{max}$ .	0 0		$V_{CC^+} - 1.5$ $V_{CC^+} - 2$	V
$V_{id}$	Differential Input Voltage <sup>(4)</sup>			$V_{CC^+}$	V
$V_{OL}$	Low Level Output Voltage $V_{id} = -1V, I_{sink} = 4mA$ $T_{amb} = +25^\circ C$ $T_{min} \leq T_{amb} \leq T_{max}$		250	400 700	mV
$I_{oh}$	High Level Output Current ( $V_{CC} = V_O = 30V, V_{id} = 1V$ ) $T_{amb} = +25^\circ C$ $T_{min} \leq T_{amb} \leq T_{max}$		0.1	1	nA $\mu A$
$I_{sink}$	Output Sink Current ( $V_{id} = -1V, V_O = 1.5V$ )	6	16		mA
$t_{re}$	Small Signal Response Time <sup>(5)</sup> ( $R_L = 5.1k\Omega$ connected to $V_{CC^+}$ )		1.3		$\mu s$
$t_{rel}$	Large Signal Response Time <sup>(6)</sup> TTL Input ( $V_{ref} = +1.4V, R_L = 5.1k\Omega$ to $V_{CC^+}$ ) Output Signal at 50% of final value Output Signal at 95% of final value			500 1	ns $\mu s$

1. At output switch point,  $V_O \approx 1.4V$ ,  $R_S = 0$  with  $V_{CC^+}$  from 5V to 30V, and over the full input common-mode range (0V to  $V_{CC^+} - 1.5V$ ).
2. The direction of the input current is out of the IC due to the PNP input stage. This current is essentially constant, independent of the state of the output, so no loading charge exists on the reference of input lines
3. The input common-mode voltage of either input signal voltage should not be allowed to go negative by more than 0.3V. The upper end of the common-mode voltage range is  $V_{CC^+} - 1.5V$ , but either or both inputs can go to +30V without damage.
4. The response time specified is for a 100mV input step with 5mV overdrive.
5. Positive excursions of input voltage may exceed the power supply level. As long as the other voltage remains within the common-mode range, the comparator will provide a proper output state. The low input voltage state must not be less than -0.3V (or 0.3V below the negative power supply, if used)
6. Maximum values are guaranteed by design.

Figure 2. Supply current vs. supply voltage

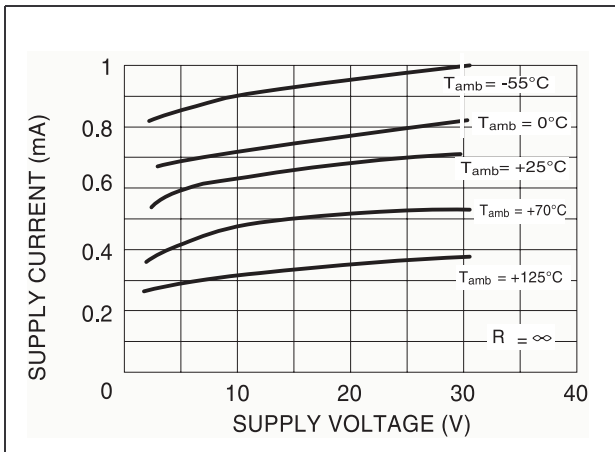

Figure 3. Input current vs. supply voltage

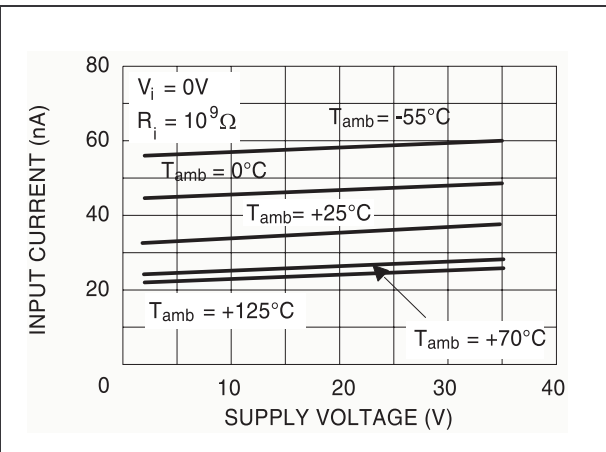

Figure 4. Output saturation voltage vs. output current

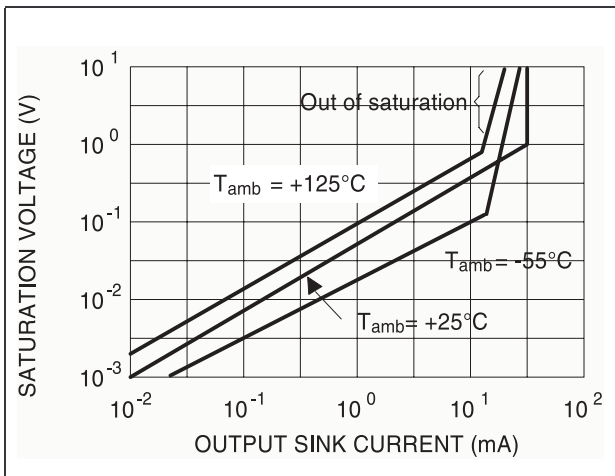

Figure 5. Response time for various input overdrives - negative transition

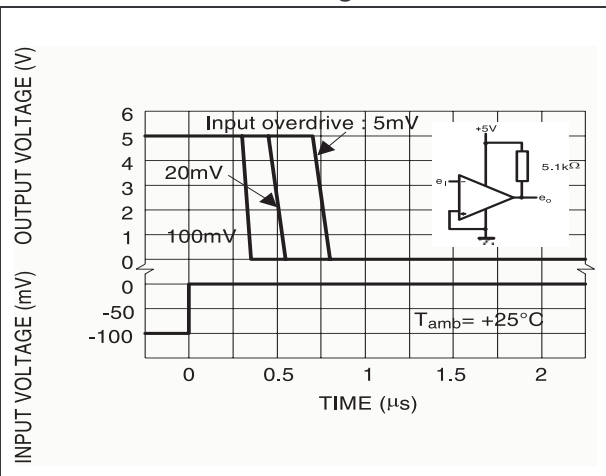

Figure 6. Response time for various input overdrives - positive transition

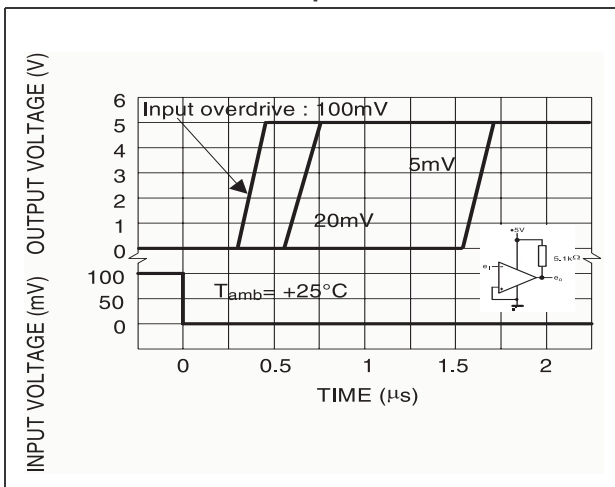

Figure 7. Basic comparator

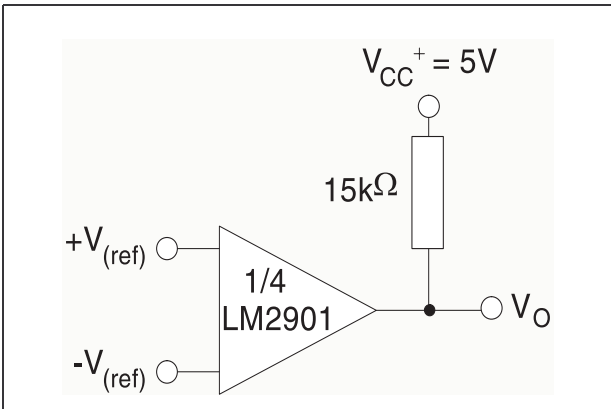

Figure 8. Driving CMOS

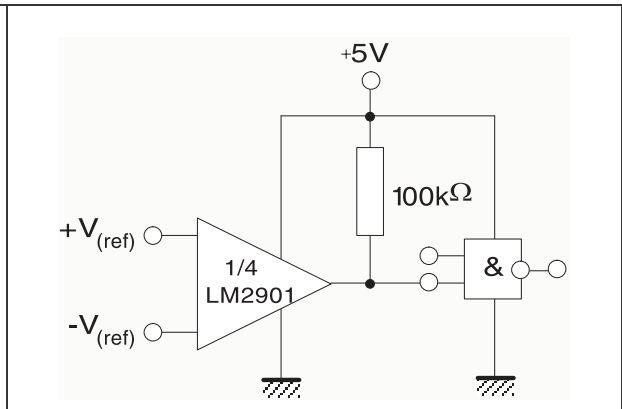

Figure 9. Driving TTL

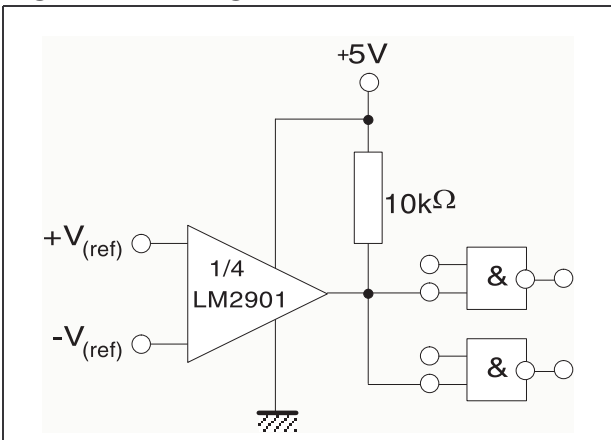

Figure 10. Low frequency op-amp

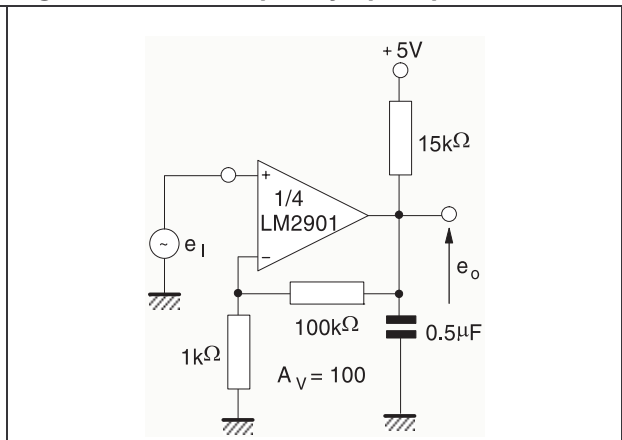

Figure 11. Low frequency op-amp

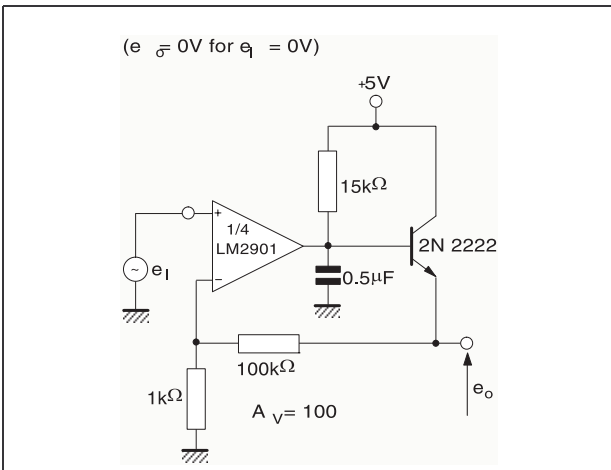

Figure 12. Transducer amplifier

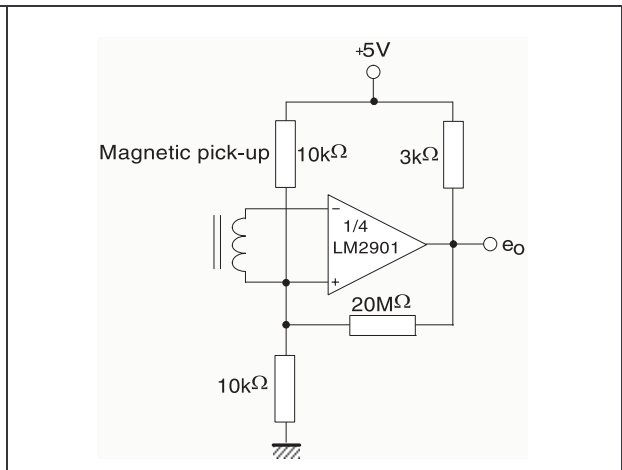

Figure 13. Low frequency op- amp with offset adjust

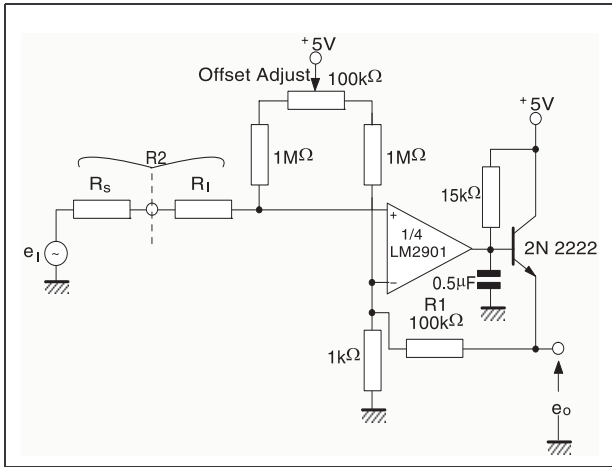

Figure 14. Zero crossing detector (single power supply)

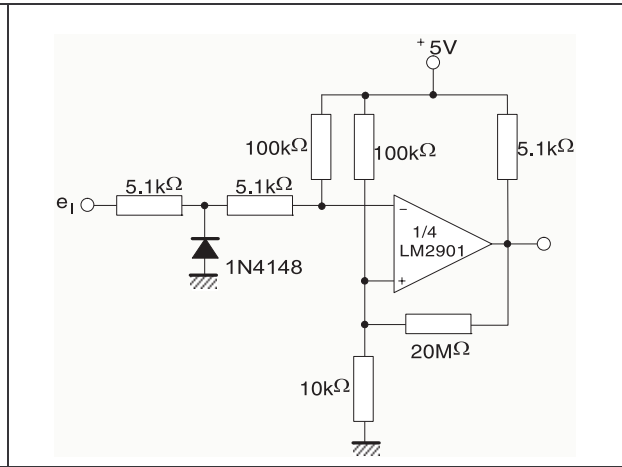

Figure 15. Limit comparator

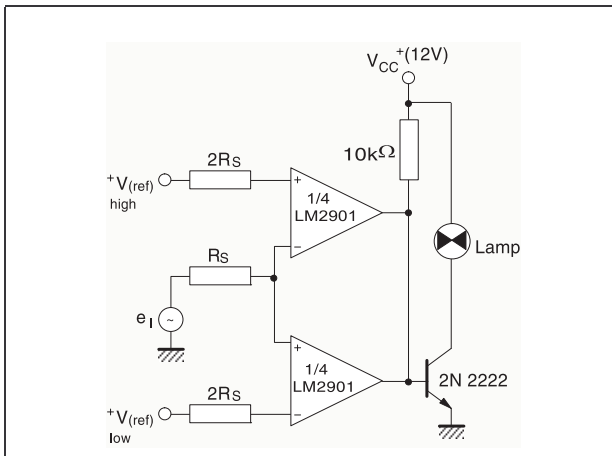

Figure 16. Split-supply applications - zero crossing detector

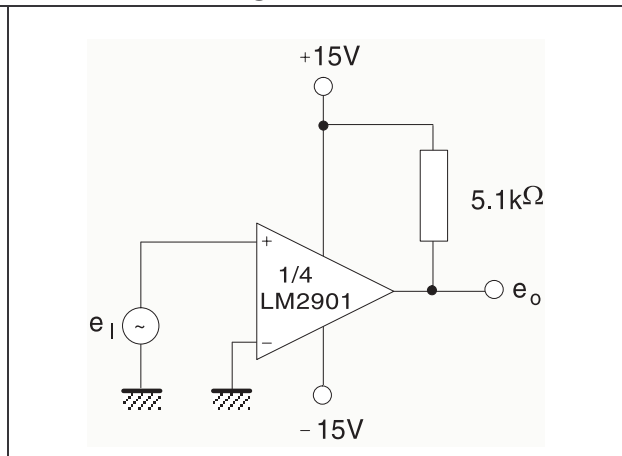

Figure 17. Crystal controlled oscillator

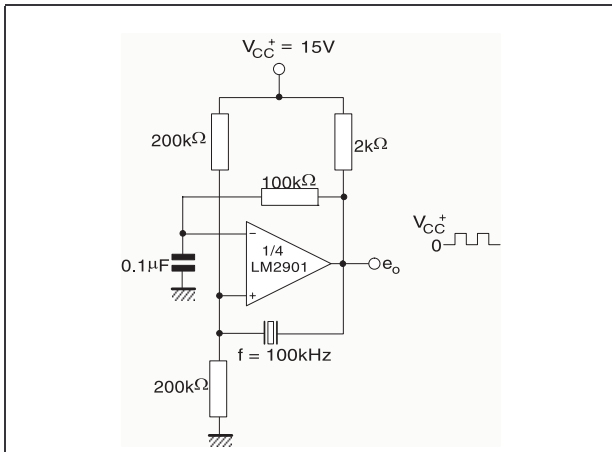

Figure 18. Comparator with a negative reference

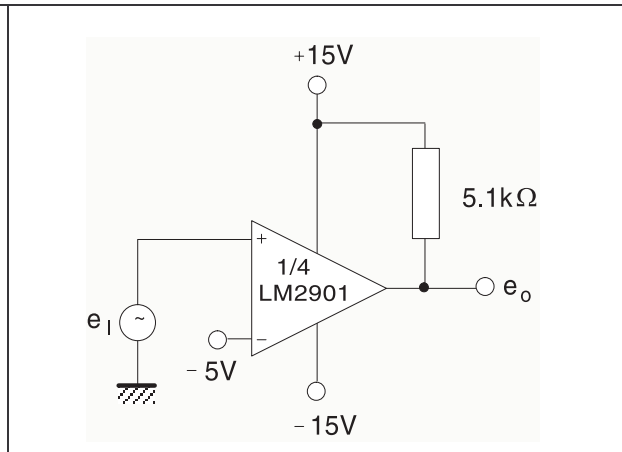

Figure 19. Time delay generator

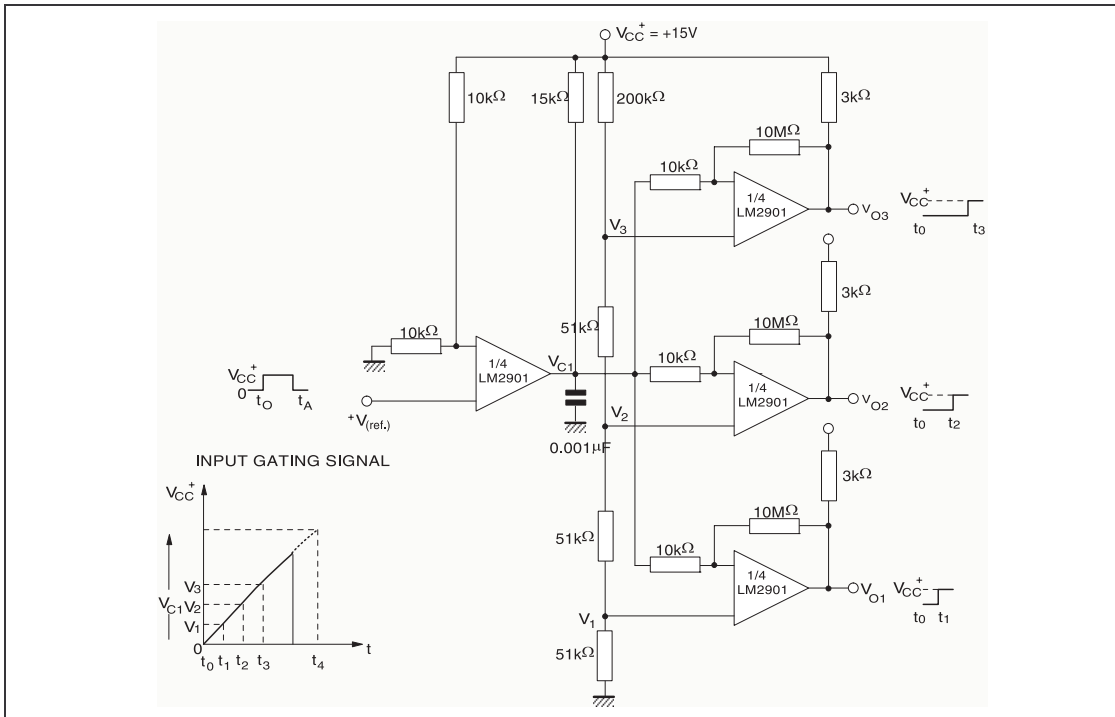
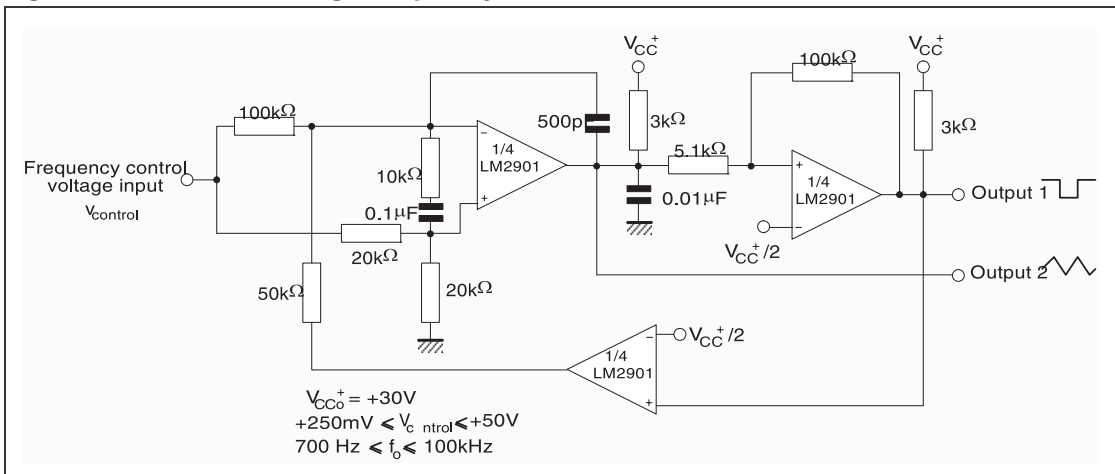

Figure 20. Two-decade high-frequency VCO





## 4 PACKAGE MECHANICAL DATA

In order to meet environmental requirements, ST offers these devices in ECOPACK<sup>®</sup> packages. These packages have a Lead-free second level interconnect. The category of second level interconnect is marked on the package and on the inner box label, in compliance with JEDEC Standard JESD97. The maximum ratings related to soldering conditions are also marked on the inner box label. ECOPACK is an ST trademark. ECOPACK specifications are available at: [www.st.com](http://www.st.com).

### 4.1 DIP14 package

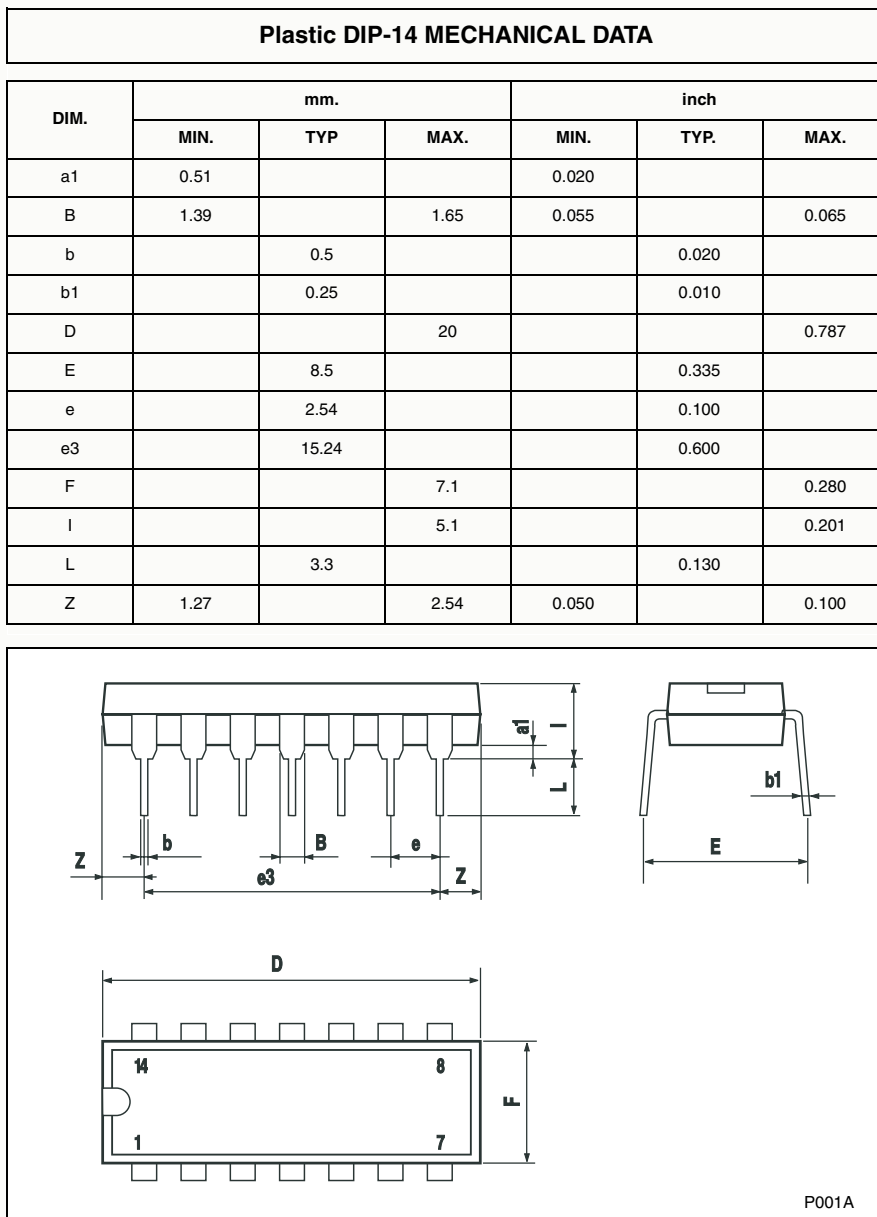

4.2 SO-14 package

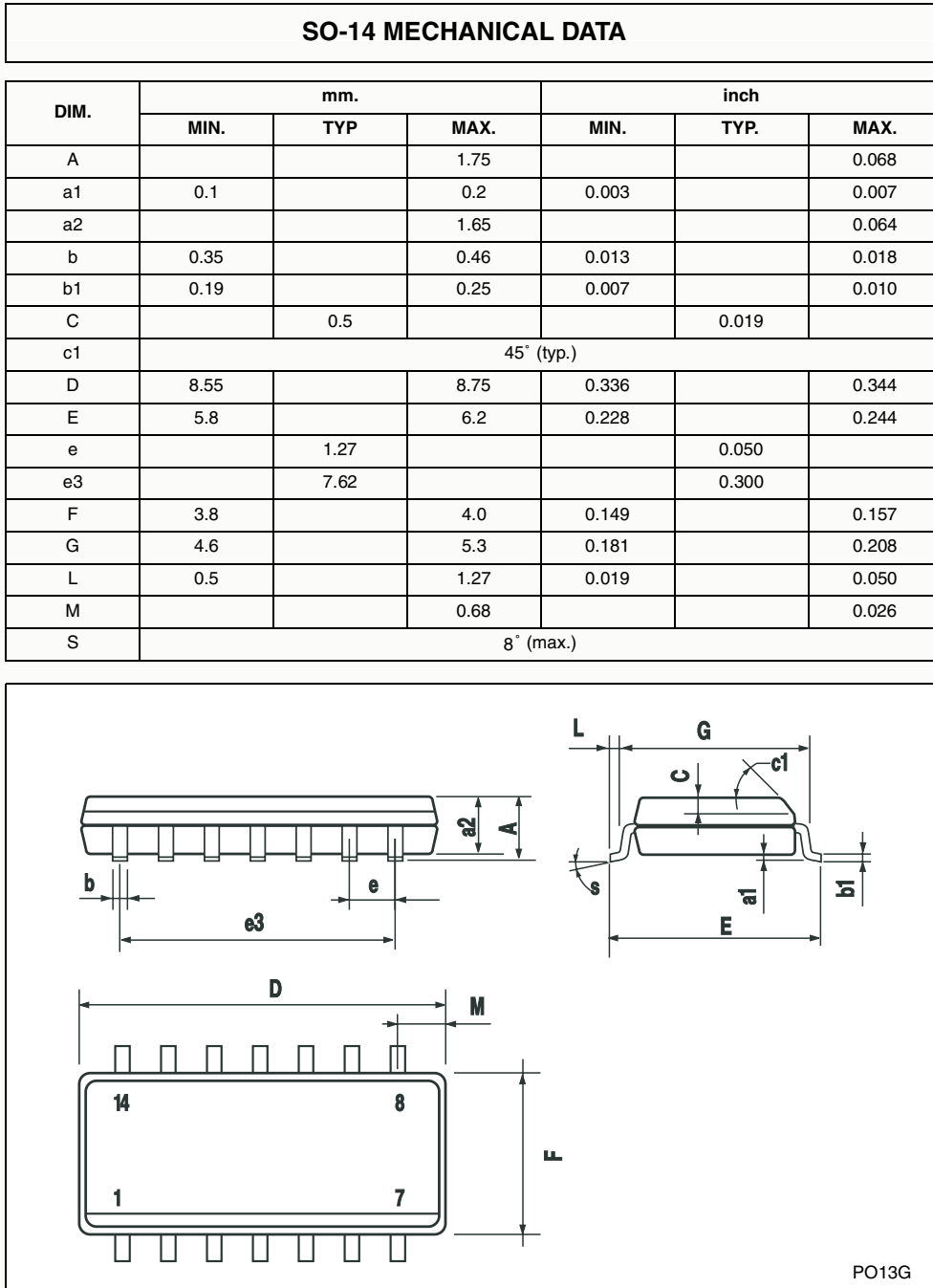

4.3 TSSOP14 package

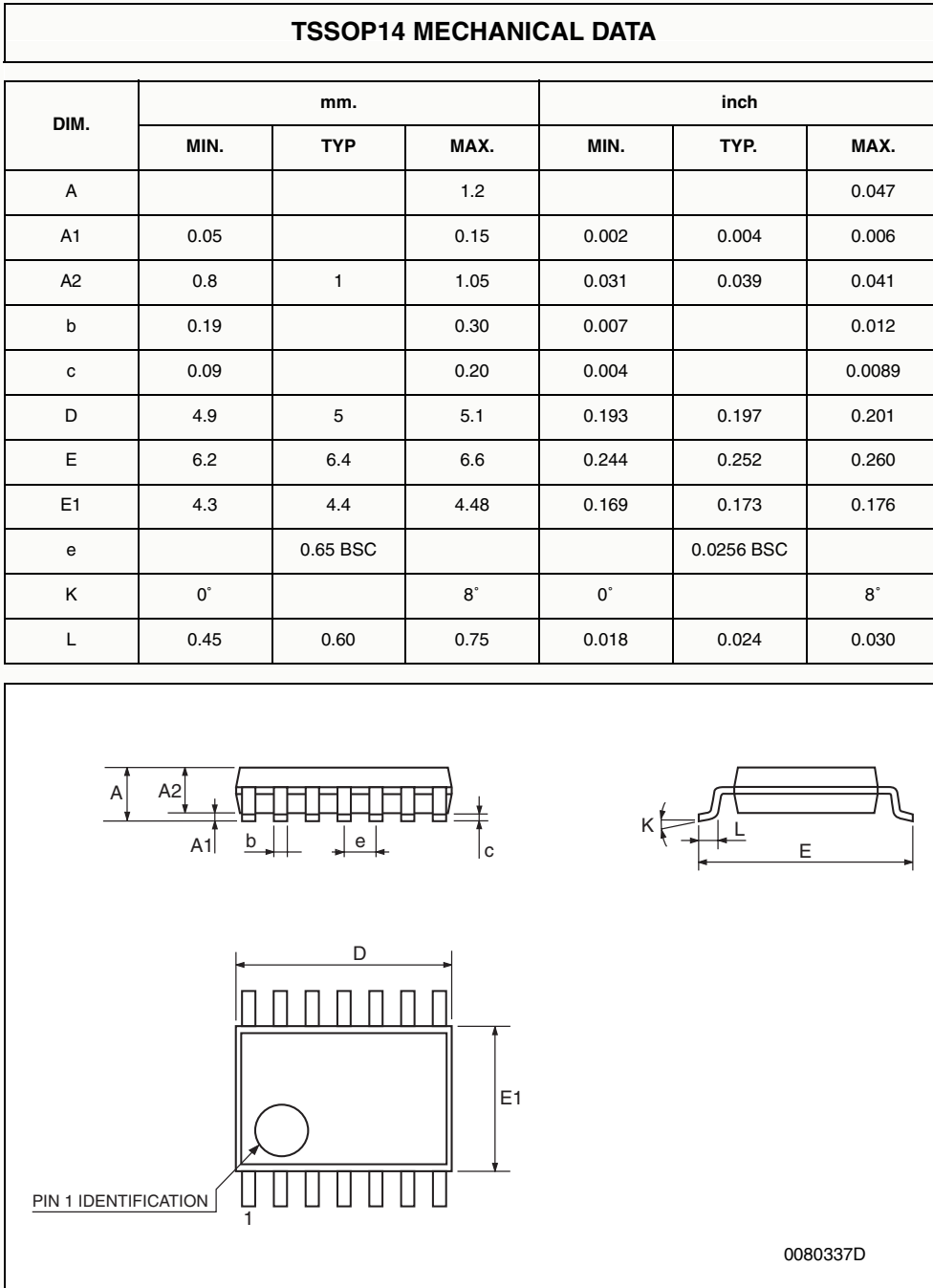

## 5 Revision History

Date	Revision	Changes
Jan. 2002	1	Initial release.
July 2005	2	1 - PPAP references inserted in the datasheet see <i>Table : Order Codes on page 1</i> . 2 - ESD protection inserted in <i>Table 1 on page 2</i> .
Oct. 2005	3	The following changes were made in this revision: – PPAP part number added in table <i>Order Codes on page 1</i> . – Formatting changes throughout.

Information furnished is believed to be accurate and reliable. However, STMicroelectronics assumes no responsibility for the consequences of use of such information nor for any infringement of patents or other rights of third parties which may result from its use. No license is granted by implication or otherwise under any patent or patent rights of STMicroelectronics. Specifications mentioned in this publication are subject to change without notice. This publication supersedes and replaces all information previously supplied. STMicroelectronics products are not authorized for use as critical components in life support devices or systems without express written approval of STMicroelectronics.

The ST logo is a registered trademark of STMicroelectronics.  
All other names are the property of their respective owners

© 2005 STMicroelectronics - All rights reserved

STMicroelectronics group of companies

Australia - Belgium - Brazil - Canada - China - Czech Republic - Finland - France - Germany - Hong Kong - India - Israel - Italy - Japan - Malaysia - Malta - Morocco - Singapore - Spain - Sweden - Switzerland - United Kingdom - United States of America

[www.st.com](http://www.st.com)