

# HITACHI

KAOHSIUNG HITACHI  
ELECTRONICS CO.,LTD  
P.O. BOX 26-27  
2,13TH EAST ST. K.E.P.Z.  
KAOHSIUNG TAIWAN R.O.C.  
TEL:(07) 8215811 (7 LINE)  
FAX:(07) 821-5815

FOR MESSRS : \_\_\_\_\_

DATE : May.13,2008

## CUSTOMER'S ACCEPTANCE SPECIFICATIONS TX07D09VM1CBB C O N T E N T S

| No. | ITEM                       | SHEET No.                   | PAGE       |
|-----|----------------------------|-----------------------------|------------|
| 1   | COVER                      | 7B64PS 2701-TX07D09VM1CBB-3 | 1-1/1      |
| 2   | RECORD OF REVISION         | 7B64PS 2702-TX07D09VM1CBB-3 | 2-1/2~2/2  |
| 3   | GENERAL DATA               | 7B64PS 2703-TX07D09VM1CBB-3 | 3-1/1      |
| 4   | ABSOLUTE MAXIMUM RATINGS   | 7B64PS 2704-TX07D09VM1CBB-3 | 4-1/2~2/2  |
| 5   | ELECTRICAL CHARACTERISTICS | 7B64PS 2705-TX07D09VM1CBB-3 | 5-1/1      |
| 6   | OPTICAL CHARACTERISTICS    | 7B64PS 2706-TX07D09VM1CBB-3 | 6-1/2~2/2  |
| 7   | BLOCK DIAGRAM              | 7B64PS 2707-TX07D09VM1CBB-3 | 7-1/1      |
| 8   | INTERFACE TIMING CHART     | 7B64PS 2708-TX07D09VM1CBB-3 | 8-1/8~8/8  |
| 9   | DIMENSIONAL OUTLINE        | 7B64PS 2709-TX07D09VM1CBB-3 | 9-1/1      |
| 10  | APPEARANCE STANDARD        | 7B64PS 2710-TX07D09VM1CBB-3 | 10-1/4~4/4 |
| 11  | PRECAUTION IN DESIGN       | 7B64PS 2711-TX07D09VM1CBB-3 | 11-1/2~2/2 |
| 12  | DESIGNATION OF LOT MARK    | 7B64PS 2712-TX07D09VM1CBB-3 | 12-1/1     |
| 13  | PRECAUTION FOR USE         | 7B64PS 2713-TX07D09VM1CBB-3 | 13-1/1     |
| 14  | RELIABILITY TEST           | 7B64PS 2714-TX07D09VM1CBB-3 | 14-1/1     |

\*When product will be discontinued, customer will be informed by HITACHI with twelve months prior to discontinuation.

ACCEPTED BY: \_\_\_\_\_

PROPOSED BY: *Dan Cheng*

## RECORD OF REVISION

| DATE                            | SHEET No.  | SUMMARY   |           |           |                           |   |                            |  |                               |                      |                                 |                     |           |           |                           |   |                            |  |                               |                      |                                 |                     |      |      |      |                     |       |      |       |      |
|---------------------------------|--|---|-----------|-----------|---------------------------|---|----------------------------|--|-------------------------------|----------------------|---------------------------------|---------------------|-----------|-----------|---------------------------|---|----------------------------|--|-------------------------------|----------------------|---------------------------------|---------------------|------|------|------|---------------------|-------|------|-------|------|
| Feb.13,'07                      | 7B64PS 2704 -<br>TX07D09VM1CBB - 2<br>Page 4 - 2/2   | <p>4.3 ENVIRONMENTAL ABSOLUTE MAXIMUM RATINGS Revised</p> <table border="1" style="width: 100%; border-collapse: collapse; margin-bottom: 10px;"> <thead> <tr> <th rowspan="2">ITEM</th> <th colspan="2">OPERATING</th> <th colspan="2">STORAGE</th> </tr> <tr> <th>Min.</th> <th>Max.</th> <th>Min.</th> <th>Max.</th> </tr> </thead> <tbody> <tr> <td>Ambient Temperature</td> <td>-20°C</td> <td>60°C</td> <td>-30°C</td> <td>70°C</td> </tr> </tbody> </table> <p style="text-align: center;">↓</p> <table border="1" style="width: 100%; border-collapse: collapse; margin-bottom: 10px;"> <thead> <tr> <th rowspan="2">ITEM</th> <th colspan="2">OPERATING</th> <th colspan="2">STORAGE</th> </tr> <tr> <th>Min.</th> <th>Max.</th> <th>Min.</th> <th>Max.</th> </tr> </thead> <tbody> <tr> <td>Ambient Temperature</td> <td>-20°C</td> <td>70°C</td> <td>-30°C</td> <td>80°C</td> </tr> </tbody> </table> <p>Note 2 : For storage condition Ta at -30°C &lt; 48h , at 70°C &lt; 100h.</p> <p style="text-align: center;">↓</p> <p>Note 2 : For storage condition Ta at -30°C &lt; 48h , at 80°C &lt; 100h.</p>   | ITEM      | OPERATING |                           | STORAGE   |                            | Min.   | Max.                          | Min.                 | Max.                            | Ambient Temperature | -20°C     | 60°C      | -30°C                     | 70°C  | ITEM                       | OPERATING  |                               | STORAGE              |                                 | Min.                | Max. | Min. | Max. | Ambient Temperature | -20°C | 70°C | -30°C | 80°C |
| ITEM                            | OPERATING  |   |           | STORAGE   |                           |   |                            |  |                               |                      |                                 |                     |           |           |                           |   |                            |  |                               |                      |                                 |                     |      |      |      |                     |       |      |       |      |
|                                 | Min.   | Max.  | Min.      | Max.      |                           |   |                            |  |                               |                      |                                 |                     |           |           |                           |   |                            |  |                               |                      |                                 |                     |      |      |      |                     |       |      |       |      |
| Ambient Temperature             | -20°C  | 60°C  | -30°C     | 70°C      |                           |   |                            |  |                               |                      |                                 |                     |           |           |                           |   |                            |  |                               |                      |                                 |                     |      |      |      |                     |       |      |       |      |
| ITEM                            | OPERATING  |   | STORAGE   |           |                           |   |                            |  |                               |                      |                                 |                     |           |           |                           |   |                            |  |                               |                      |                                 |                     |      |      |      |                     |       |      |       |      |
|                                 | Min.   | Max.  | Min.      | Max.      |                           |   |                            |  |                               |                      |                                 |                     |           |           |                           |   |                            |  |                               |                      |                                 |                     |      |      |      |                     |       |      |       |      |
| Ambient Temperature             | -20°C  | 70°C  | -30°C     | 80°C      |                           |   |                            |  |                               |                      |                                 |                     |           |           |                           |   |                            |  |                               |                      |                                 |                     |      |      |      |                     |       |      |       |      |
|                                 | 7B64PS 2711 -<br>TX07D09VM1CBB - 2<br>Page 11 - 2/2  | <p>11.4 STORAGE Revised</p> <p>(2) Keep the temperature between -30°C and 70°C at normal humidity.</p> <p style="text-align: center;">↓</p> <p>(2) Keep the temperature between -30°C and 80°C at normal humidity.</p>  |           |           |                           |   |                            |  |                               |                      |                                 |                     |           |           |                           |   |                            |  |                               |                      |                                 |                     |      |      |      |                     |       |      |       |      |
|                                 | 7B64PS 2714 -<br>TX07D09VM1CBB - 2<br>Page 14 - 1/1  | <p>14. RELIABILITY TEST Revised</p> <table border="1" style="width: 100%; border-collapse: collapse; margin-bottom: 10px;"> <thead> <tr> <th>TEST ITEM</th> <th>CONDITION</th> </tr> </thead> <tbody> <tr> <td>Heat Cycle<br/>(Operation)</td> <td>● -20±3°C...1hour , 60±3°C...1 hour<br/>● 30 cycles, 8 hours / cycle</td> </tr> <tr> <td>Thermal Shock<br/>(Storage)</td> <td>● -30±3°C...30 minutes , 70±3°C...30 minutes<br/>● 100 cycles , 1 hour / cycle<br/>● Temperature transition time is within 4 minutes</td> </tr> <tr> <td>High Temperature<br/>(Storage)</td> <td>● 70±3°C...100 hours</td> </tr> <tr> <td>High Temperature<br/>(Operation)</td> <td>● 60±3°C...48 hours</td> </tr> </tbody> </table> <p style="text-align: center;">↓</p> <table border="1" style="width: 100%; border-collapse: collapse;"> <thead> <tr> <th>TEST ITEM</th> <th>CONDITION</th> </tr> </thead> <tbody> <tr> <td>Heat Cycle<br/>(Operation)</td> <td>● -20±3°C...1hour , 70±3°C...1 hour<br/>● 30 cycles, 8 hours / cycle</td> </tr> <tr> <td>Thermal Shock<br/>(Storage)</td> <td>● -30±3°C...30 minutes , 80±3°C...30 minutes<br/>● 100 cycles , 1 hour / cycle<br/>● Temperature transition time is within 4 minutes</td> </tr> <tr> <td>High Temperature<br/>(Storage)</td> <td>● 80±3°C...100 hours</td> </tr> <tr> <td>High Temperature<br/>(Operation)</td> <td>● 70±3°C...48 hours</td> </tr> </tbody> </table> | TEST ITEM | CONDITION | Heat Cycle<br>(Operation) | ● -20±3°C...1hour , 60±3°C...1 hour<br>● 30 cycles, 8 hours / cycle | Thermal Shock<br>(Storage) | ● -30±3°C...30 minutes , 70±3°C...30 minutes<br>● 100 cycles , 1 hour / cycle<br>● Temperature transition time is within 4 minutes | High Temperature<br>(Storage) | ● 70±3°C...100 hours | High Temperature<br>(Operation) | ● 60±3°C...48 hours | TEST ITEM | CONDITION | Heat Cycle<br>(Operation) | ● -20±3°C...1hour , 70±3°C...1 hour<br>● 30 cycles, 8 hours / cycle | Thermal Shock<br>(Storage) | ● -30±3°C...30 minutes , 80±3°C...30 minutes<br>● 100 cycles , 1 hour / cycle<br>● Temperature transition time is within 4 minutes | High Temperature<br>(Storage) | ● 80±3°C...100 hours | High Temperature<br>(Operation) | ● 70±3°C...48 hours |      |      |      |                     |       |      |       |      |
| TEST ITEM                       | CONDITION  |   |           |           |                           |   |                            |  |                               |                      |                                 |                     |           |           |                           |   |                            |  |                               |                      |                                 |                     |      |      |      |                     |       |      |       |      |
| Heat Cycle<br>(Operation)       | ● -20±3°C...1hour , 60±3°C...1 hour<br>● 30 cycles, 8 hours / cycle  |   |           |           |                           |   |                            |  |                               |                      |                                 |                     |           |           |                           |   |                            |  |                               |                      |                                 |                     |      |      |      |                     |       |      |       |      |
| Thermal Shock<br>(Storage)      | ● -30±3°C...30 minutes , 70±3°C...30 minutes<br>● 100 cycles , 1 hour / cycle<br>● Temperature transition time is within 4 minutes |   |           |           |                           |   |                            |  |                               |                      |                                 |                     |           |           |                           |   |                            |  |                               |                      |                                 |                     |      |      |      |                     |       |      |       |      |
| High Temperature<br>(Storage)   | ● 70±3°C...100 hours   |   |           |           |                           |   |                            |  |                               |                      |                                 |                     |           |           |                           |   |                            |  |                               |                      |                                 |                     |      |      |      |                     |       |      |       |      |
| High Temperature<br>(Operation) | ● 60±3°C...48 hours  |   |           |           |                           |   |                            |  |                               |                      |                                 |                     |           |           |                           |   |                            |  |                               |                      |                                 |                     |      |      |      |                     |       |      |       |      |
| TEST ITEM                       | CONDITION  |   |           |           |                           |   |                            |  |                               |                      |                                 |                     |           |           |                           |   |                            |  |                               |                      |                                 |                     |      |      |      |                     |       |      |       |      |
| Heat Cycle<br>(Operation)       | ● -20±3°C...1hour , 70±3°C...1 hour<br>● 30 cycles, 8 hours / cycle  |   |           |           |                           |   |                            |  |                               |                      |                                 |                     |           |           |                           |   |                            |  |                               |                      |                                 |                     |      |      |      |                     |       |      |       |      |
| Thermal Shock<br>(Storage)      | ● -30±3°C...30 minutes , 80±3°C...30 minutes<br>● 100 cycles , 1 hour / cycle<br>● Temperature transition time is within 4 minutes |   |           |           |                           |   |                            |  |                               |                      |                                 |                     |           |           |                           |   |                            |  |                               |                      |                                 |                     |      |      |      |                     |       |      |       |      |
| High Temperature<br>(Storage)   | ● 80±3°C...100 hours   |   |           |           |                           |   |                            |  |                               |                      |                                 |                     |           |           |                           |   |                            |  |                               |                      |                                 |                     |      |      |      |                     |       |      |       |      |
| High Temperature<br>(Operation) | ● 70±3°C...48 hours  |   |           |           |                           |   |                            |  |                               |                      |                                 |                     |           |           |                           |   |                            |  |                               |                      |                                 |                     |      |      |      |                     |       |      |       |      |

RECORD OF REVISION

| DATE       | SHEET No.   | SUMMARY   |
|------------|---|---|
| May.13,'08 | 7B64PS 2712 -<br>TX07D09VM1CBB - 3<br>Page 12 - 1/1 | 12.2 Location of lot mark<br>Lot mark change: Print on FPC → Barcode label on frame |
|            |   |   |

### 3.GENERAL DATA

The specifications are applied to the following TFT-LCD (Transmissive Amorphas silicon TFT ) module with Back-light unit. LCD driving circuit and LED driving circuit do not obtain in this module.

|                             |  |
|-----------------------------|--|
| (1) Part Name               | TX07D09VM1CBB  |
| (2) Module Dimensions       | 50.54(W)mm x 68.62(H)mm x 2.6(D)mm typ.<br>Except FPC Area |
| (3) Effective Display Area  | 41.04(W)mm x 54.72(H)mm                                    |
| (4) Dot Pitch               | 0.057mm x 3(R,G,B)(W) x 0.171(H)mm                         |
| (5) Resolution              | 240 x 3(R,G,B)(W) x 320 (H) dots                           |
| (6) Color Pixel Arrangement | R,G,B Vertical Stripe                                      |
| (7) LCD Type                | Transmissive Color TFT LCD (Normally White)                |
| (8) Display Type            | Active Matrix  |
| (9) Number of Colors        | 262 <sup>K</sup> Colors (R,G,B 6 Bit Digital each)         |
| (10) Backlight              | Light Emitting Diode (LED) x 5                             |
| (11) Weight                 | (18)g  |
| (12) Interface              | 45 pin C-MOS   |
| (13) Viewing Direction      | 6 O'clock (The direction it's hard to be discolored)       |

## 4. ABSOLUTE MAXIMUM RATINGS

### 4.1 ELECTRICAL ABSOLUTE MAXIMUM RATINGS OF LCD

| ITEM  |                       | SYMBOL          | MIN.            | MAX.  | UNIT                | REMARKS |
|---|-----------------------|-----------------|-----------------|-------|---------------------|---------|
| Power Supply for Logic                          |                       | VCC             | -0.3            | 3.6   | V                   |         |
| Power Supply Voltage for Source Driver and Vcom |                       | VDH             | -0.3            | 6.0   | V                   |         |
| Input Voltage                                   |                       | V <sub>i</sub>  | 0               | VCC   | V                   | (1)     |
| Gate  | Power Supply for Gate | High            | V <sub>GH</sub> | -0.3  | V <sub>GL</sub> +20 | V       |
|   |                       | Low             | V <sub>GL</sub> | -6    | 0.3                 | V       |
| LED   | Forward Current       | I <sub>F</sub>  | -               | 30    | mA                  | (2)     |
|   | Pulse Forward Current | I <sub>FP</sub> | -               | 80    | mA                  | (3)     |
|   | Reverse Voltage       | V <sub>R</sub>  | -               | 5     | V                   |         |
| Static Electricity                              |                       | -               | -               | (±15) | kV                  | (4) (5) |

Note (1) Hsync, Vsync, DCLK , R0~R5 , G0~G5 , B0~B5

(2)

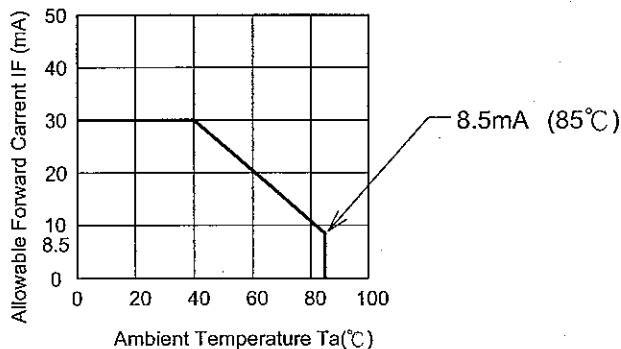

(3) I<sub>FP</sub> Conditions : pulse width  $\leq 10$ ms and Duty  $\leq 1/10$

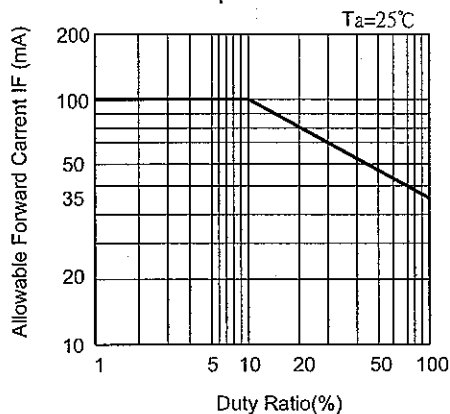

(4) Make certain you are grounded when handling LCM.

(5) Testing condition : 200pF - 0  $\Omega$  , 25° C - 70%RH.

## 4.2 ENVIRONMENTAL ABSOLUTE MAXIMUM RATINGS

| ITEM                | OPERATING      |      | STORAGE        |                                   | REMARKS              |
|---------------------|----------------|------|----------------|-----------------------------------|----------------------|
|                     | Min.           | Max. | Min.           | Max.                              |                      |
| Ambient Temperature | -20°C          | 70°C | -30°C          | 80°C                              | (Note 2,3,6,7,9,10)  |
| Humidity            | (Note 1)       |      | (Note 1)       |                                   | Without condensation |
| Vibration           | -              | -    | -              | (11.76)m/s <sup>2</sup><br>(1.2G) | (Note 4,5)           |
| Shock               | -              | -    | -              | (490)m/s <sup>2</sup><br>(50G)    | (Note 5,8)           |
| Corrosive Gas       | Not Acceptable |      | Not Acceptable |                                   |                      |

Note 1 :  $T_a \leq 40^\circ\text{C}$  : 85%RH max.

$T_a > 40^\circ\text{C}$  : Absolute humidity must be lower than the humidity of 85%RH at  $40^\circ\text{C}$ .  
as follow diagram.

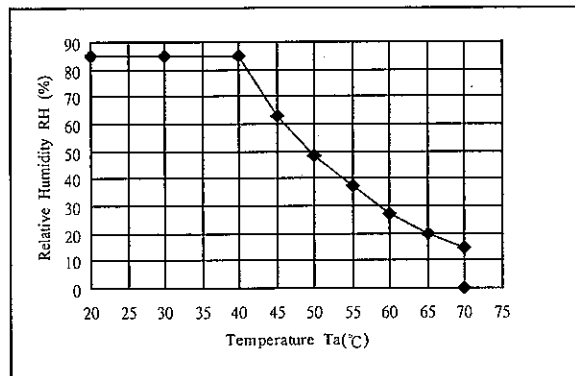

Note 2 : For storage condition  $T_a$  at  $-30^\circ\text{C} < 48\text{h}$ , at  $80^\circ\text{C} < 100\text{h}$ .

For operating condition  $T_a$  at  $-20^\circ\text{C} < 100\text{h}$

Note 3 : Background color changes slightly depending on ambient temperature.

This phenomenon is reversible.

Note 4 : 5Hz~100Hz(Except resonance frequency)

Note 5 : This LCM will resume normal operation after finishing the test.

Note 6 : The response time will be slower as low temperature.

Note 7 : Only operation is guaranteed at operating temperature. Contrast, response time, another display quality are evaluated at  $25^\circ\text{C}$ .

Note 8 : Pulse Width : 10ms

Note 9 : This is panel surface temperature, not ambient temperature.

Note 10 : If LED is driven by high current, the life time of LED will be reduced, also high temperature and high humidity.

## 5. ELECTRICAL CHARACTERISTICS

### 5.1 ELECTRICAL CHARACTERISTICS OF LCD

Ta=25°C, VSS=0V

| ITEM  | SYMBOL | CONDITION      | MIN.     | TYP.  | MAX.   | UNIT |
|---|--------|----------------|----------|-------|--------|------|
| Power Supply Voltage for logic                  | VCC    | -              | 2.5      | 3.0   | 3.3    | V    |
| Power Supply Voltage for Source Driver and Vcom | VDH    | -              | 4.5      | 5.0   | 6.0    |      |
| Input voltage for logic (note 1)                | Vi     | "H" level      | 0.8VCC   | -     | VCC    | V    |
|   |        | "L" level      | VSS      | -     | 0.2VCC |      |
| Power Supply for LCD                            | VGH    | -              | 14.0     | 15.0  | 16.0   | V    |
|   | VGL    |                | -16.0    | -15.0 | -14.0  |      |
|   | VCOM   |                | VCOM-VSS | -     | 2.2    |      |
| Power Supply Current (note 2)                   | ICC    | VCC-VSS=3.0V   | -        | 0.6   | -      | mA   |
|   | IDH    | VDH-VSS=5.0V   | -        | 2.5   | -      |      |
|   | IGH    | VGH-VSS=15.0V  | -        | 0.06  | -      |      |
|   | IGL    | VGL-VSS=-15.0V | -        | 0.22  | -      |      |
| Vsync Frequency                                 | fV     | -              | 54       | 60    | 68     | Hz   |
| Hsync Frequency                                 | fH     | -              | 18.57    | 20.77 | 22.73  | kHz  |
| DCLK Frequency                                  | fCLK   | -              | 5.0      | 5.6   | 6.5    | MHz  |

Note 1 : DCLK, RD0~RD5, GD0~GD5, BD0~BD5.

Note 2 : fV=60Hz, Ta=25°C, Pattern used as display pattern : All black.

Note 3 : Need to make sure of flickering and rippling of display when setting the frame frequency in your set.

### 5.2 ELECTRICAL CHARACTERISTICS OF BACK LIGHT

| ITEM                | SYMBOL | CONDITION | MIN. | TYP.  | MAX. | UNIT | REMARKS    |
|---------------------|--------|-----------|------|-------|------|------|------------|
| LED Input Voltage   | VF     | IF=20mA   | -    | (3.2) | 3.5  | V    | LED / Part |
| LED Forward Current | IF     | -         | -    | 20    | 25   | mA   | LED / Part |
| LED Reverse Current | IR     | VR=5V     | -    | -     | 50   | μA   | LED / Part |

## 6. OPTICAL CHARACTERISTICS

### 6.1 OPTICAL CHARACTERISTICS OF LCD (BACK LIGHT ON)

Ta=25°C

| ITEM                          | SYMBOL      | CONDITION                     | MIN.                          | TYP.   | MAX.   | UNIT              | NOTE        |     |
|-------------------------------|-------------|-------------------------------|-------------------------------|--------|--------|-------------------|-------------|-----|
| Brightness(center)            | B           | $\phi=0^\circ \theta=0^\circ$ | -                             | 420    | -      | cd/m <sup>2</sup> | (1)         |     |
| Uniformity                    | -           | $\phi=0^\circ \theta=0^\circ$ | 70                            | -      | -      | %                 | (2),(3),(4) |     |
| Viewing Angle                 | $\theta x$  | $\phi=0^\circ, K \geq 5.0$    | -                             | 60     | -      | deg               | (5),(6)     |     |
|                               | $\theta x'$ | $\phi=180^\circ, K \geq 5.0$  | -                             | 80     | -      |                   |             |     |
|                               | $\theta y$  | $\phi=90^\circ, K \geq 5.0$   | -                             | 70     | -      |                   |             |     |
|                               | $\theta y'$ | $\phi=270^\circ, K \geq 5.0$  | -                             | 70     | -      |                   |             |     |
| Contrast Ratio                | K           | $\phi=0^\circ \theta=0^\circ$ | 200                           | 300    | -      | -                 | (4)         |     |
| Response Time (rise-fall)     | tr+tf       | $\phi=0^\circ \theta=0^\circ$ | -                             | (30)   | -      | ms                | (8)         |     |
| Color Tone<br>(Primary Color) | Red         | x                             | $\phi=0^\circ \theta=0^\circ$ | (0.55) | (0.60) | (0.65)            | -           | (4) |
|                               |             | y                             |                               | (0.29) | (0.34) | (0.39)            | -           |     |
|                               | Green       | x                             |                               | (0.31) | (0.36) | (0.41)            | -           |     |
|                               |             | y                             |                               | (0.50) | (0.55) | (0.60)            | -           |     |
|                               | Blue        | x                             |                               | (0.10) | (0.15) | (0.20)            | -           |     |
|                               |             | y                             |                               | (0.09) | (0.14) | (0.19)            | -           |     |
|                               | White       | x                             |                               | (0.29) | (0.34) | (0.39)            | -           |     |
|                               |             | y                             |                               | (0.30) | (0.35) | (0.40)            | -           |     |

(Measurement condition : HITACHI standard)

Note 1 : Active area center  
LED Current : 20mA / Part

Note (4)~(7) : See page 6-2/2

Note 2 : Driving Condition  
Display Pattern : White Raster  
LED Current : 20mA / Part  
Measurement of the following  
9 places on the display.

Note 3 : Definition of the brightness uniformity

$$\left( \frac{\text{Min. brightness}}{\text{Max. brightness}} \right) \times 100$$

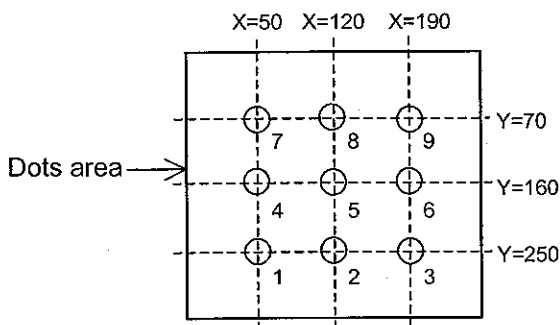



Note 4 : Measurement Condition

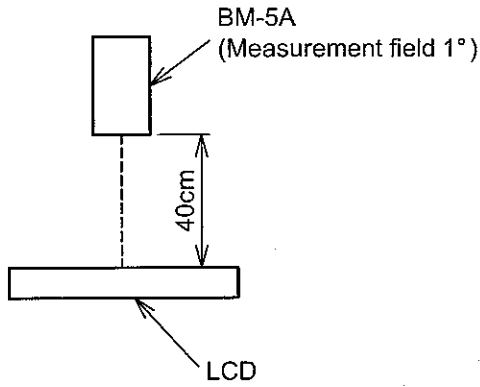

Note 5 : Definition of  $\theta$  and  $\phi$   
(Normal)  
Viewing direction

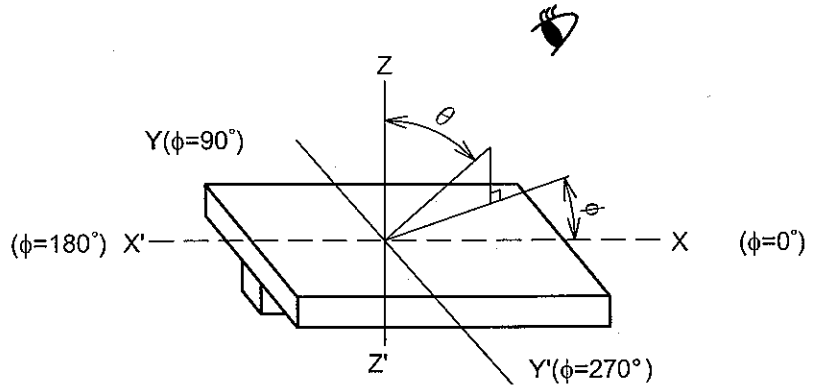

Note 6 : Definition of Viewing angle

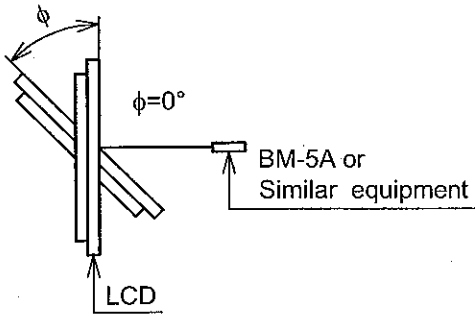

Note 7 : Definition of contrast "K"

$$K = \frac{\text{White Brightness}}{\text{Black Brightness}}$$

Note 8 : Definition optical response time

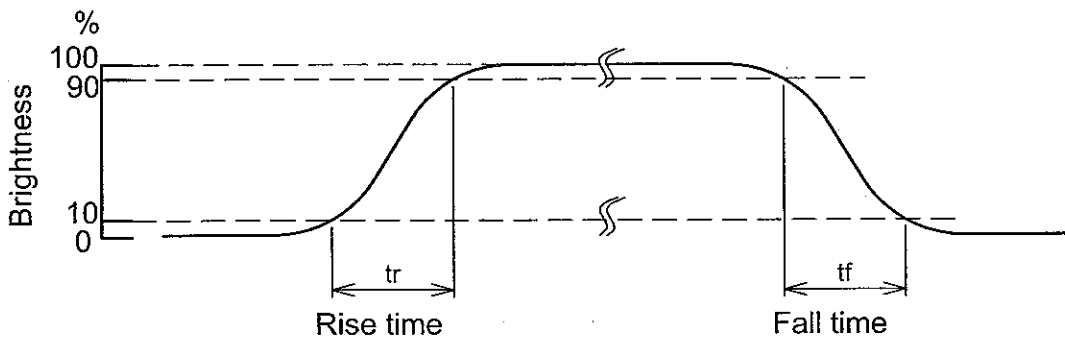
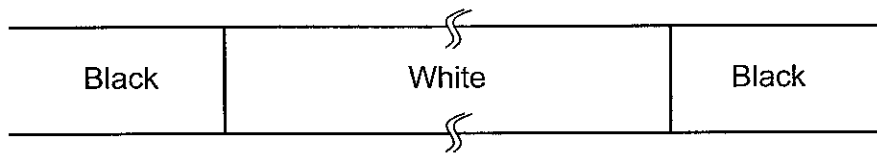

# 7. BLOCK DIAGRAM

For example

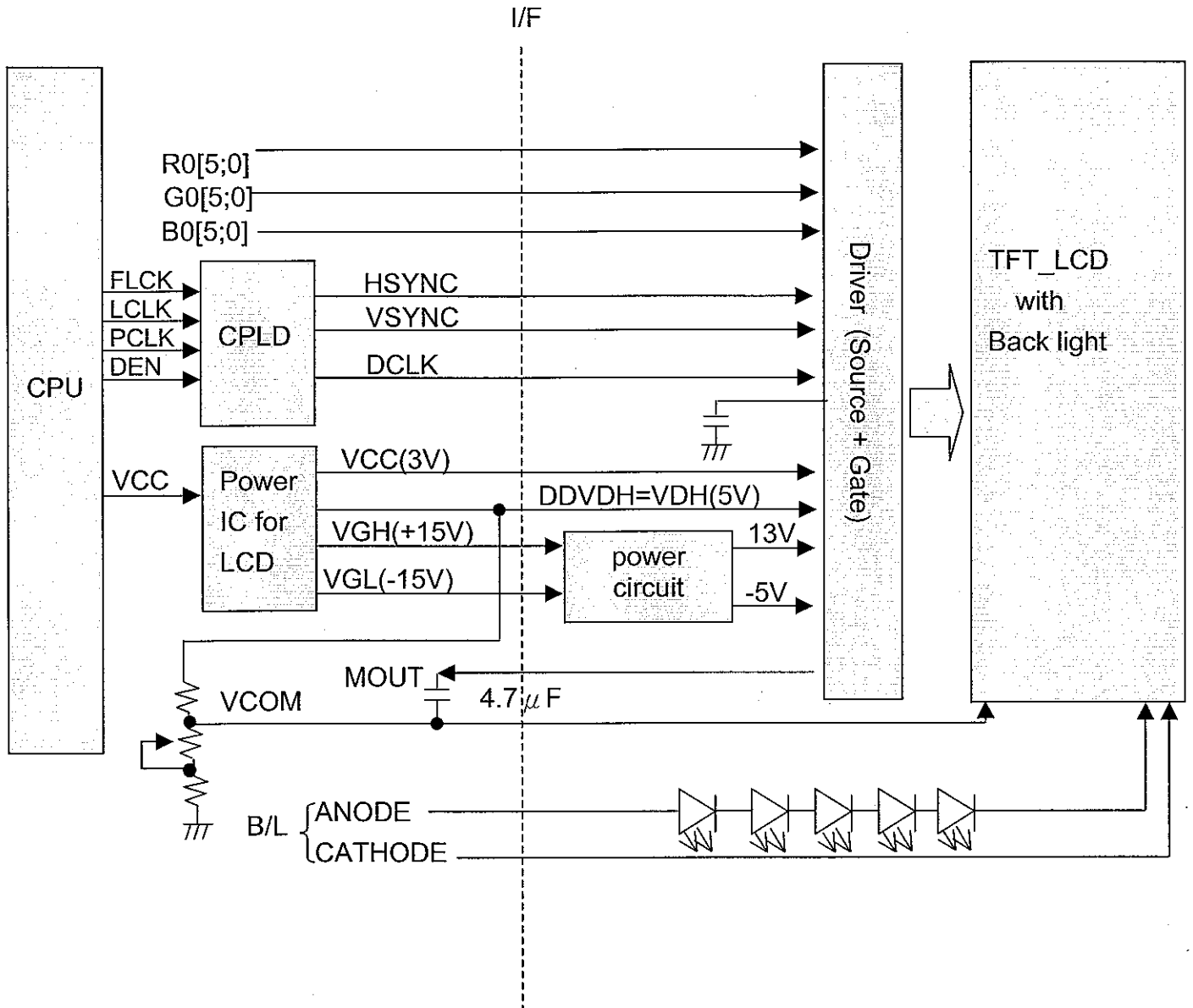

# 8. INTERFACE TIMING

## 8.1 INTERFACE TIMING

| ITEM   | SYMBOL        | MIN. | TYP. | MAX. | UNIT  | NOTE    |
|--|---------------|------|------|------|-------|---------|
| DOTCLK Cycle Time                                  | tCYCD         | 83   | -    | -    | ns    | 1 trans |
|  |               | 60   | -    | -    |       | 3 trans |
| DOTCLK Low Level Pulse Width                       | PWDL          | 25   | -    | -    | ns    | -       |
| DOTCLK High Level Pulse Width                      | PWDL          | 25   | -    | -    | ns    | -       |
| VSYNC Setup Time                                   | tVSYNCS       | 0    | -    | 1    | clock | -       |
| HSYNC Setup Time                                   | tHSYNCS       | 0    | -    | 1    | clock | -       |
| RGB Data Setup Time                                | TPDS          | 10   | -    | -    | ns    | -       |
| RGB Data Hold Time                                 | TPDH          | 20   | -    | -    | ns    | -       |
| DOTCLK/VSYNC/HSYNC Rising Edge , Falling Edge Time | trgbr / trgbf | -    | -    | 20   | ns    | -       |

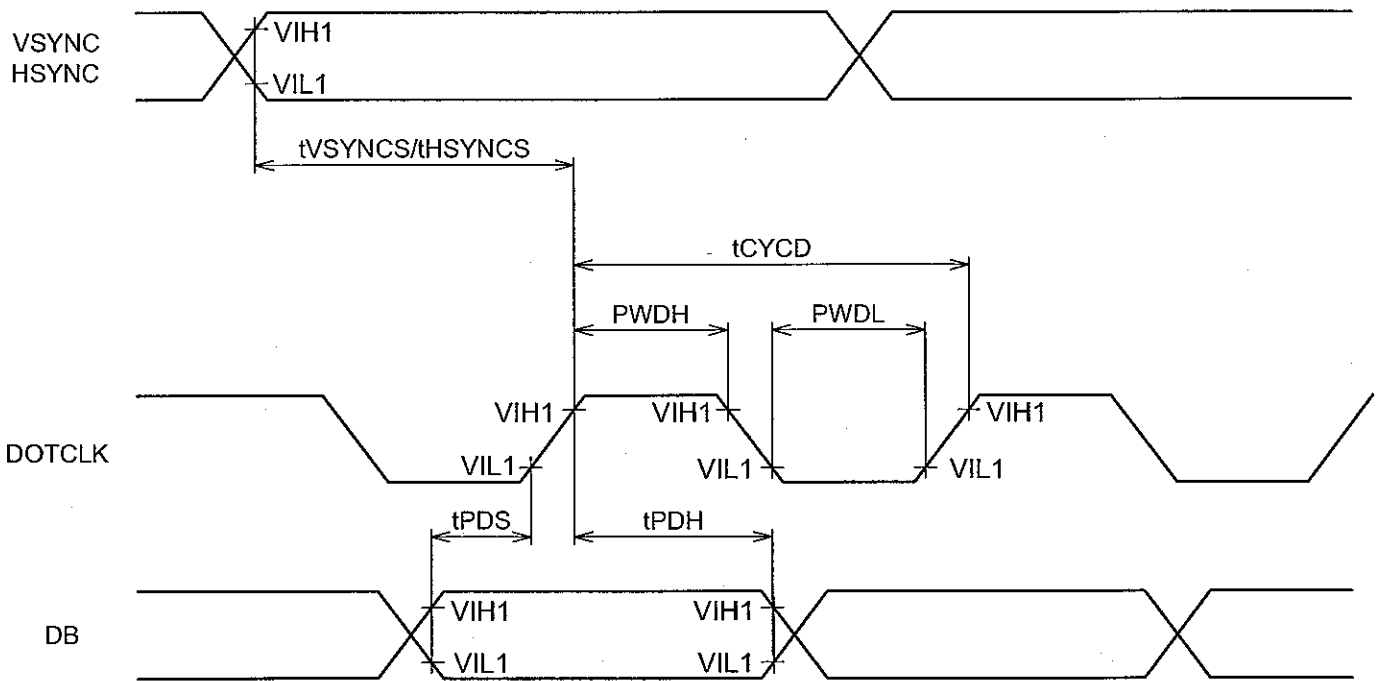



(3) Note about VSYNC timing setting

Check the timing chart of VSYNC and HSYNC , If timing setting is not set as fig1, it must be set as fig2 .

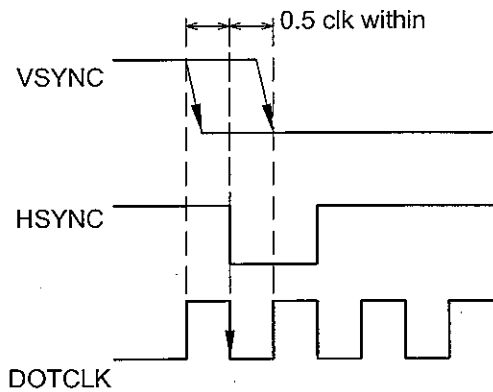

fig1. VSYNC timing

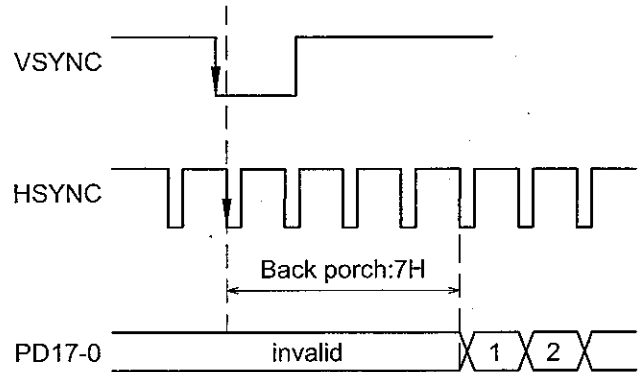
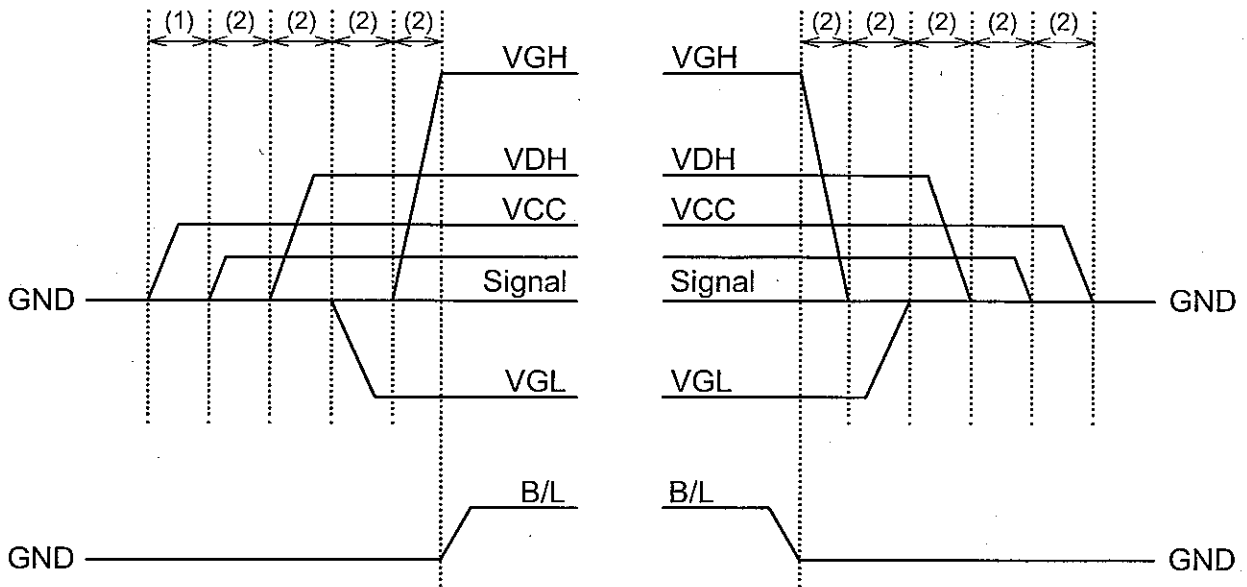

fig2. Vertical back porch regulation

- (4) The DOTCLK signal must be supplied consecutively.
- (5) Front and back porch (VBP , VFP) must be set before and after the display operation period.
- (6) The front porch period continues until the next input of VSYNC signal.

### 8.3 POWER ON/OFF SEQUENCE



- (1): VCC must be in stable situation, then Signal can be input.  
 (2): 0~1s

## 8.4 RELATIONSHIP BETWEEN DISPLAYED COLOR AND INPUT DATA

### 8.4.1 Display Colors

| Input color |           | Red Data |    |    |     |    |    | Green Data |    |    |     |    |    | Blue Data |    |    |     |    |    |
|-------------|-----------|----------|----|----|-----|----|----|------------|----|----|-----|----|----|-----------|----|----|-----|----|----|
|             |           | R5       | R4 | R3 | R2  | R1 | R0 | G5         | G4 | G3 | G2  | G1 | G0 | B5        | B4 | B3 | B2  | B1 | B0 |
|             |           | MSB      |    |    | LSB |    |    | MSB        |    |    | LSB |    |    | MSB       |    |    | LSB |    |    |
| Basic Color | Black     | 0        | 0  | 0  | 0   | 0  | 0  | 0          | 0  | 0  | 0   | 0  | 0  | 0         | 0  | 0  | 0   | 0  | 0  |
|             | Red(0)    | 1        | 1  | 1  | 1   | 1  | 1  | 0          | 0  | 0  | 0   | 0  | 0  | 0         | 0  | 0  | 0   | 0  | 0  |
|             | Green(0)  | 0        | 0  | 0  | 0   | 0  | 0  | 1          | 1  | 1  | 1   | 1  | 1  | 0         | 0  | 0  | 0   | 0  | 0  |
|             | Blue(0)   | 0        | 0  | 0  | 0   | 0  | 0  | 0          | 0  | 0  | 0   | 0  | 0  | 1         | 1  | 1  | 1   | 1  | 1  |
|             | Cyan      | 0        | 0  | 0  | 0   | 0  | 0  | 1          | 1  | 1  | 1   | 1  | 1  | 1         | 1  | 1  | 1   | 1  | 1  |
|             | Magenta   | 1        | 1  | 1  | 1   | 1  | 1  | 0          | 0  | 0  | 0   | 0  | 0  | 1         | 1  | 1  | 1   | 1  | 1  |
|             | Yellow    | 1        | 1  | 1  | 1   | 1  | 1  | 1          | 1  | 1  | 1   | 1  | 1  | 0         | 0  | 0  | 0   | 0  | 0  |
|             | White     | 1        | 1  | 1  | 1   | 1  | 1  | 1          | 1  | 1  | 1   | 1  | 1  | 1         | 1  | 1  | 1   | 1  | 1  |
| Red         | Black     | 0        | 0  | 0  | 0   | 0  | 0  | 0          | 0  | 0  | 0   | 0  | 0  | 0         | 0  | 0  | 0   | 0  | 0  |
|             | Red(62)   | 0        | 0  | 0  | 0   | 0  | 1  | 0          | 0  | 0  | 0   | 0  | 0  | 0         | 0  | 0  | 0   | 0  | 0  |
|             | Red(61)   | 0        | 0  | 0  | 0   | 1  | 0  | 0          | 0  | 0  | 0   | 0  | 0  | 0         | 0  | 0  | 0   | 0  | 0  |
|             | :         | :        | :  | :  | :   | :  | :  | :          | :  | :  | :   | :  | :  | :         | :  | :  | :   | :  | :  |
|             | :         | :        | :  | :  | :   | :  | :  | :          | :  | :  | :   | :  | :  | :         | :  | :  | :   | :  | :  |
|             | Red(2)    | 1        | 1  | 1  | 1   | 0  | 1  | 0          | 0  | 0  | 0   | 0  | 0  | 0         | 0  | 0  | 0   | 0  | 0  |
|             | Red(1)    | 1        | 1  | 1  | 1   | 1  | 0  | 0          | 0  | 0  | 0   | 0  | 0  | 0         | 0  | 0  | 0   | 0  | 0  |
|             | Red(0)    | 1        | 1  | 1  | 1   | 1  | 1  | 0          | 0  | 0  | 0   | 0  | 0  | 0         | 0  | 0  | 0   | 0  | 0  |
| Green       | Black     | 0        | 0  | 0  | 0   | 0  | 0  | 0          | 0  | 0  | 0   | 0  | 0  | 0         | 0  | 0  | 0   | 0  | 0  |
|             | Green(62) | 0        | 0  | 0  | 0   | 0  | 0  | 0          | 0  | 0  | 0   | 0  | 1  | 0         | 0  | 0  | 0   | 0  | 0  |
|             | Green(61) | 0        | 0  | 0  | 0   | 0  | 0  | 0          | 0  | 0  | 0   | 1  | 0  | 0         | 0  | 0  | 0   | 0  | 0  |
|             | :         | :        | :  | :  | :   | :  | :  | :          | :  | :  | :   | :  | :  | :         | :  | :  | :   | :  | :  |
|             | :         | :        | :  | :  | :   | :  | :  | :          | :  | :  | :   | :  | :  | :         | :  | :  | :   | :  | :  |
|             | Green(2)  | 0        | 0  | 0  | 0   | 0  | 0  | 1          | 1  | 1  | 1   | 0  | 1  | 0         | 0  | 0  | 0   | 0  | 0  |
|             | Green(1)  | 0        | 0  | 0  | 0   | 0  | 0  | 1          | 1  | 1  | 1   | 1  | 0  | 0         | 0  | 0  | 0   | 0  | 0  |
|             | Green(0)  | 0        | 0  | 0  | 0   | 0  | 0  | 1          | 1  | 1  | 1   | 1  | 1  | 0         | 0  | 0  | 0   | 0  | 0  |
| Blue        | Black     | 0        | 0  | 0  | 0   | 0  | 0  | 0          | 0  | 0  | 0   | 0  | 0  | 0         | 0  | 0  | 0   | 0  | 0  |
|             | Blue(62)  | 0        | 0  | 0  | 0   | 0  | 0  | 0          | 0  | 0  | 0   | 0  | 0  | 0         | 0  | 0  | 0   | 0  | 1  |
|             | Blue(61)  | 0        | 0  | 0  | 0   | 0  | 0  | 0          | 0  | 0  | 0   | 0  | 0  | 0         | 0  | 0  | 0   | 1  | 0  |
|             | :         | :        | :  | :  | :   | :  | :  | :          | :  | :  | :   | :  | :  | :         | :  | :  | :   | :  | :  |
|             | :         | :        | :  | :  | :   | :  | :  | :          | :  | :  | :   | :  | :  | :         | :  | :  | :   | :  | :  |
|             | Blue(2)   | 0        | 0  | 0  | 0   | 0  | 0  | 0          | 0  | 0  | 0   | 0  | 0  | 1         | 1  | 1  | 1   | 0  | 1  |
|             | Blue(1)   | 0        | 0  | 0  | 0   | 0  | 0  | 0          | 0  | 0  | 0   | 0  | 0  | 1         | 1  | 1  | 1   | 1  | 0  |
|             | Blue(0)   | 0        | 0  | 0  | 0   | 0  | 0  | 0          | 0  | 0  | 0   | 0  | 0  | 1         | 1  | 1  | 1   | 1  | 1  |





8.5 POWER SUPPLY CIRCUIT FOR LED BL

LED B/L

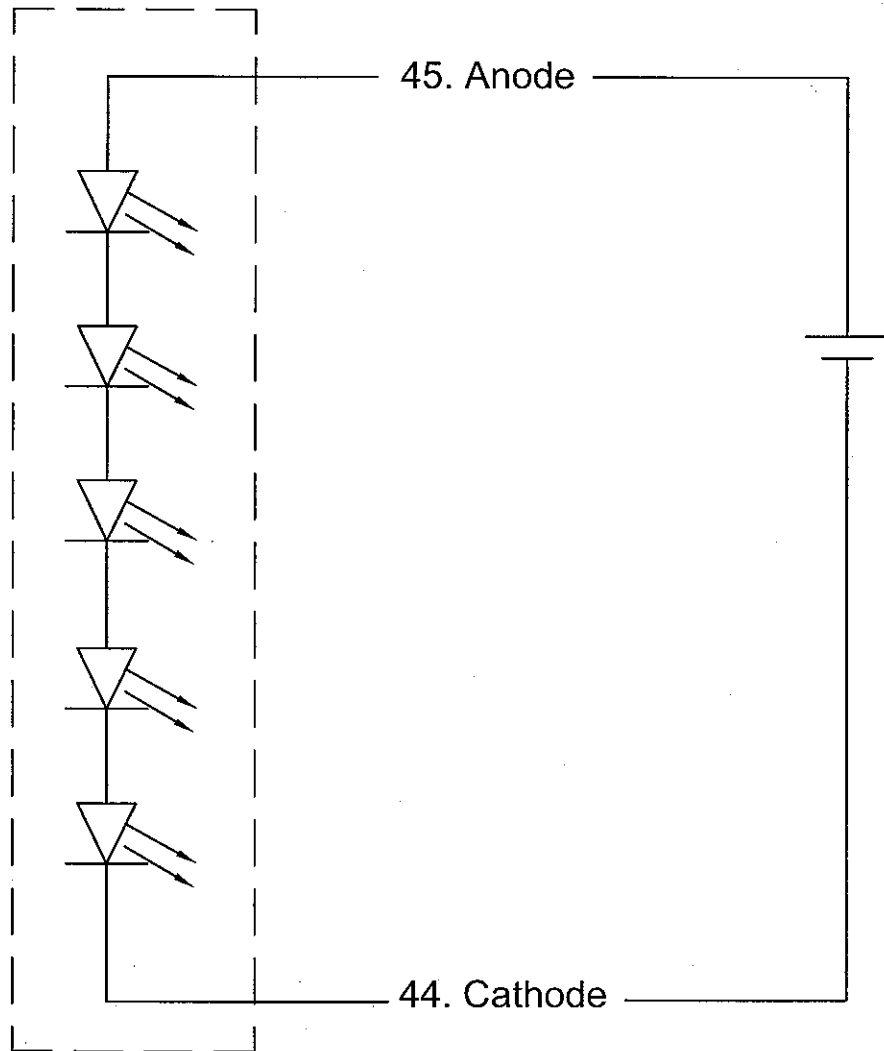

## 8.5 INTERNAL PIN CONNECTION

CN1 (FPC) : Adaptable socket : FH23-45S-0.3SHW(Hirose Electric Co.,Ltd)

| PIN No. | SIGNAL  | FUNCTION                                     |
|---------|---------|--|
| 1       | VSS     | Ground                                       |
| 2       | VCOM    | Common electrode                             |
| 3       | VSS     | Ground                                       |
| 4       | MOUT    | Alternating signal for Vcom output           |
| 5       | VSS     | Ground                                       |
| 6       | NC      | No connection                                |
| 7       | NC      | No connection                                |
| 8       | NC      | No connection                                |
| 9       | VCC     | Power Supply Voltage for logic               |
| 10      | DCLK    | Dot clock signal                             |
| 11      | NC      | No connection                                |
| 12      | VSS     | Ground                                       |
| 13      | D20     | (LSB)  |
| 14      | D21     |  |
| 15      | D22     | Red Data                                     |
| 16      | D23     |  |
| 17      | D24     | (MSB)  |
| 18      | D25     |  |
| 19      | D10     | (LSB)  |
| 20      | D11     |  |
| 21      | D12     |  |
| 22      | D13     | Green Data                                   |
| 23      | D14     |  |
| 24      | D15     | (MSB)  |
| 25      | D00     | (LSB)  |
| 26      | D01     |  |
| 27      | D02     | Blue Data                                    |
| 28      | D03     |  |
| 29      | D04     | (MSB)  |
| 30      | D05     |  |
| 31      | VSS     | Ground                                       |
| 32      | VDH     | Power Supply Voltage for source Dr. and Vcom |
| 33      | HSYNC   | Horizontal Sync Signal                       |
| 34      | VGL     | Power Supply for Gate Driver (Low)           |
| 35      | NC      | No Connection                                |
| 36      | VGH     | Power Supply for Gate Driver (High)          |
| 37      | VSYNC   | Vertical Sync Signal                         |
| 38      | VSS     | Ground                                       |
| 39      | NC      | No connection                                |
| 40      | NC      | No connection                                |
| 41      | NC      | No connection                                |
| 42      | NC      | No connection                                |
| 43      | VSS     | Ground                                       |
| 44      | CATHODE | Supply voltage for LED                       |
| 45      | ANODE   | Supply voltage for LED                       |

# 9. DIMENSIONAL OUTLINE

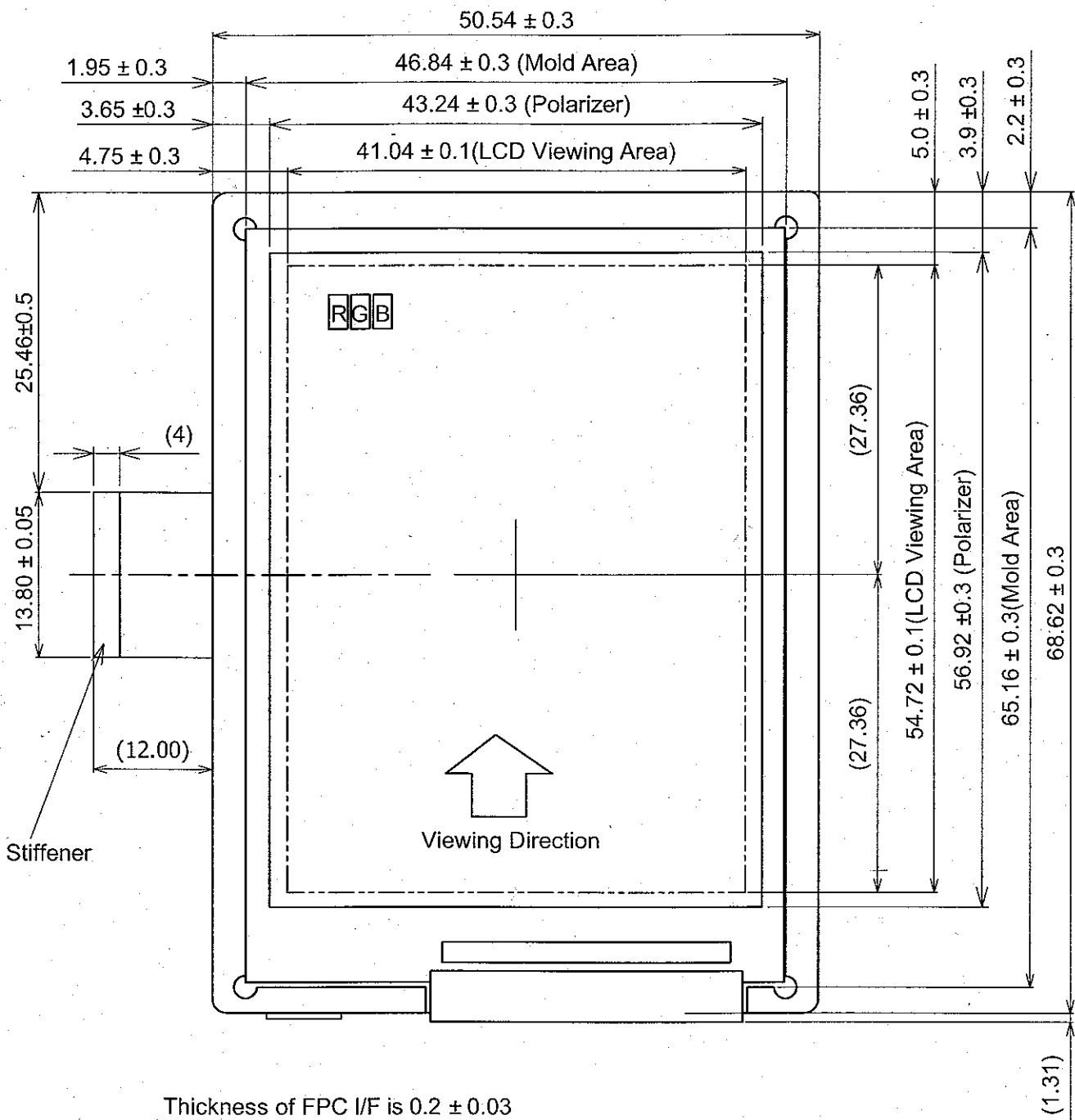

Thickness of FPC I/F is  $0.2 \pm 0.03$

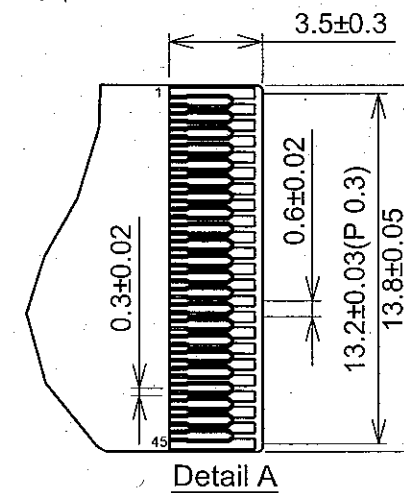
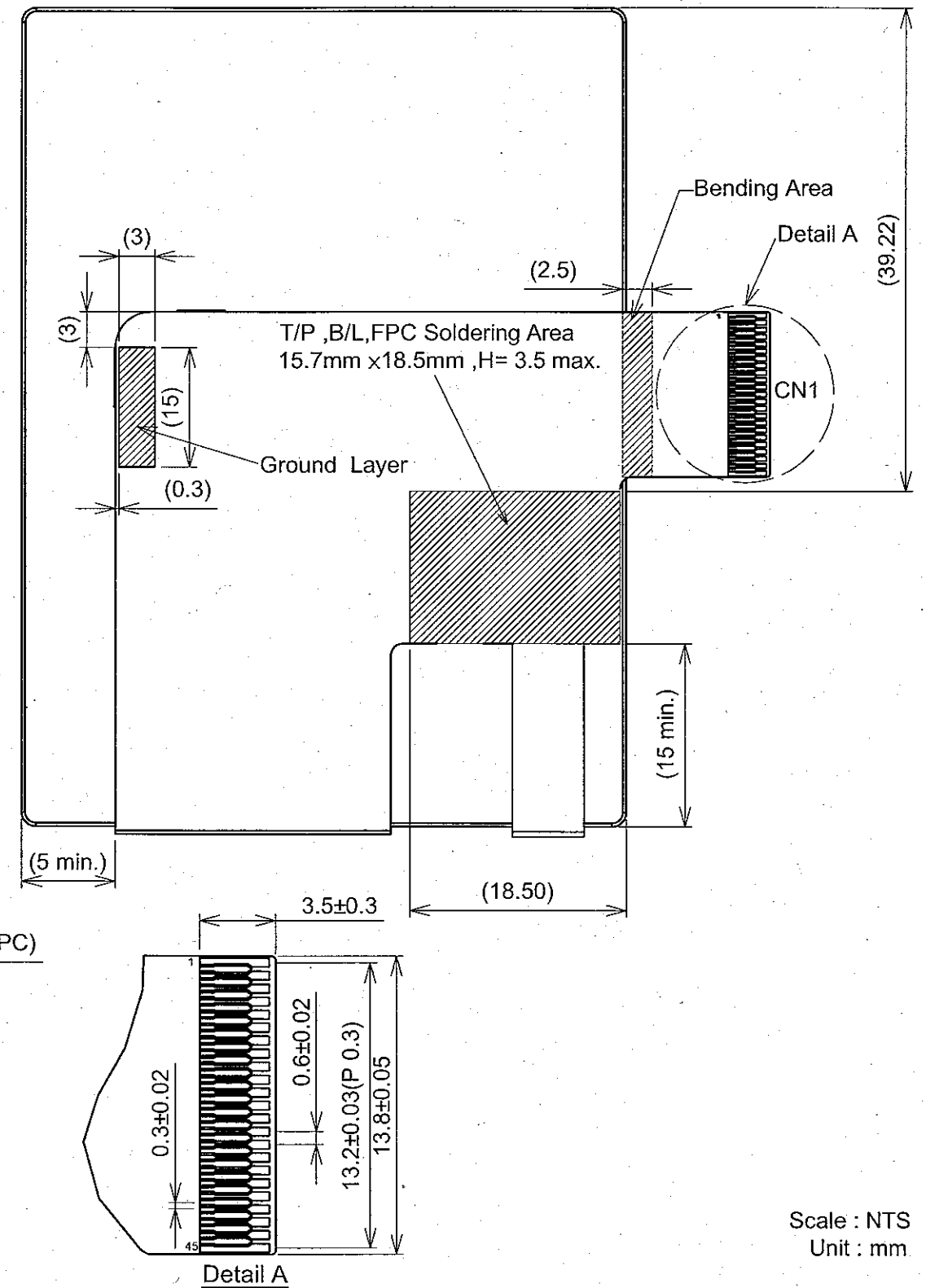
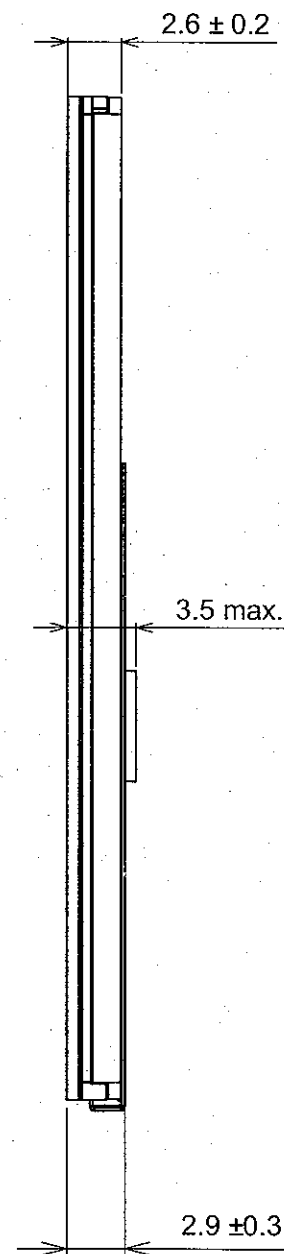

Scale : NTS  
Unit : mm

## 10. APPEARANCE STANDARD

### 10.1 APPEARANCE INSPECTION CONDITION

Visual inspection should be done under the following condition.

- (1) The inspection should be done in a dark room. (More than 1000lx) and non-directive)
- (2) The distance between eyes of an inspector and the LCD module is 30cm.
- (3) The viewing zone is shown the figure.

Viewing angle  $\leq 25^\circ$

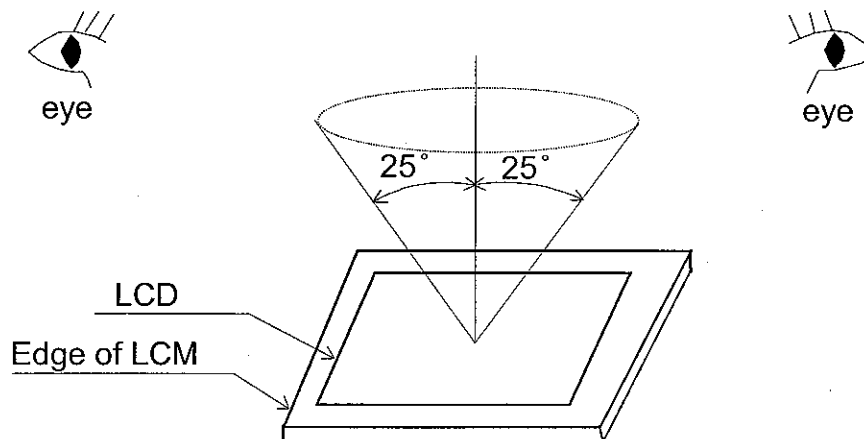

### 10.2 DEFINITION OF ZONE

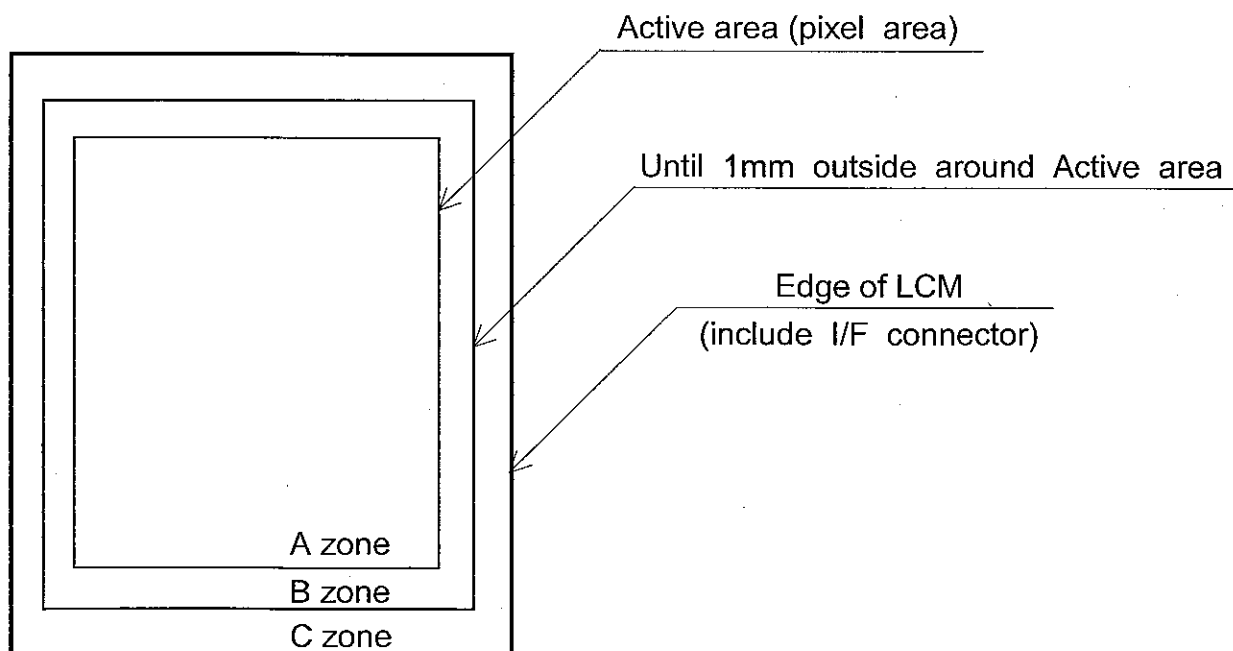

10.3 APPEARANCE SPECIFICATION

(1) LCM Appearance

\*) If the problem related to this section occurs about this item, the responsible persons of both party (Customer and HITACHI) will discuss the matter in detail.

| No.              | ITEM   | CRITERIA  |                       |                              | APPLIED ZONE |     |
|------------------|--|---|-----------------------|------------------------------|--------------|-----|
| L<br>C<br>M      | Scratches  | Length<br>L(mm)   | Width<br>W(mm)        | Maximum number<br>acceptable | A,B          |     |
|                  |  | $L < 2.0$   | $W \leq 0.03$         | ignored                      |              |     |
|                  | Dent   | Distinguished one is acceptable<br>(To be judged by limit sample (Note4)) |                       |                              | A            |     |
|                  | Wrinkles in Polarize                                   | Same as above   |                       |                              | A            |     |
|                  | Stains<br>Foreign<br>Materials<br>Bubbles<br>Dark spot | Filamentous (Line shape)  |                       |                              |              | A,B |
|                  |  | Length<br>L(mm)   | Width<br>W(mm)        | Maximum number<br>acceptable |              |     |
|                  |  | $L \leq 0.5$  | $W \leq 0.1$          | ignored                      |              |     |
|                  |  | $0.5 \leq L \leq 2.5$   | $W \leq 0.1$          | 3                            |              |     |
|                  |  | $2.5 < L$   | $W > 0.1$             | none                         |              |     |
|                  |  | Round(Dot shape)  |                       |                              |              | A,B |
|                  |  | Average diameter<br>D(mm)   |                       | Maximum number<br>acceptable |              |     |
|                  |  | $D \leq 0.2$  |                       | ignored                      |              |     |
|                  |  | $0.2 < D \leq 0.4$  |                       | 3                            |              |     |
|                  |  | $0.4 < D$   |                       | none                         |              |     |
|                  | Those wiped out easily are acceptable                  |   |                       |                              |              |     |
| Color Tone       | To be judged by limit sample (Note4)                   |   |                       | A                            |              |     |
| Color Uniformity | Same as above  |   |                       | A                            |              |     |
| Rubbing Scratch  | To be judged by limit sample (Note4)                   |   |                       | -                            |              |     |
| L<br>C<br>D      | Line Defect  | Not allowed   |                       |                              | A            |     |
|                  | Bright Dots  | Red + Green + Blue  | -                     | $\leq 4$ dots                |              |     |
|                  |  | Red + Green + Blue  | Linked 2 dots         | $\leq 2$ set                 |              |     |
|                  |  |   | Linked 3 or more dots | 0 set                        |              |     |
|                  | Dark Dots  | Black   | -                     | $\leq 4$ dots                |              |     |
|                  |  |   | Linked 2 dots         | $\leq 2$ set                 |              |     |
|                  |  |   | Linked 3 or more dots | 0 set                        |              |     |
| Total            | Bright dots + Dark dots                                |   |                       | $\leq 6$ dots                |              |     |

(2) Glass indentation

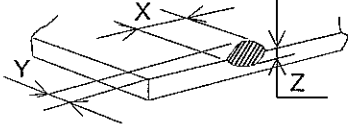
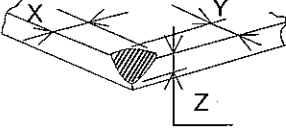
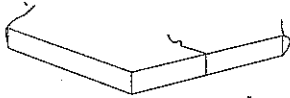
| ITEM               | SPECIFICATIONS  |      |      |    |
|--------------------|---|------|------|----|
| Common Indentation |  | X    | Y    | Z  |
|                    |   | ≤5.0 | ≤1.0 | ≤t |
| Corner Broken      |  | X    | Y    | Z  |
|                    |   | ≤2.0 | ≤2.0 | ≤t |
| Proceeding Crack   |  | None |      |    |

Note 1 : Definition of average diameter (D)

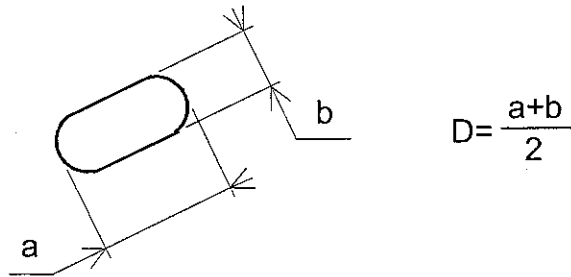

Note 2 : Definition of length (L) and width (W)

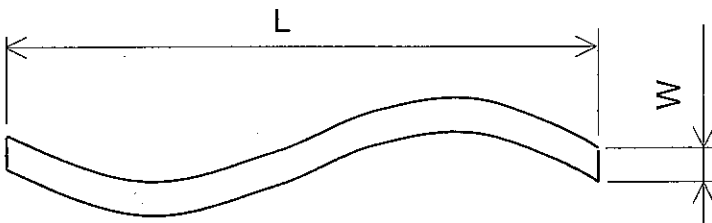

Note 3 : Definition of dot defect

- (a) Regardless of bright or intermittent bright , 1/3 or more defects of a dot area is counted as the defect dot.
- (b) Bright dots are measured while the display is black.
- (c) Dark dots are measured while the display is illuminated with red , green and blue.
- (d) The pattern of linked 2 dots is as follows.

|                                     |
|-------------------------------------|
| : Bright dot             : Dark dot |
| The pattern of linked 2 dots        |
|                                     |
|                                     |
|                                     |

Note 4 : When problem occurred, it judged the basis of both company deliberation after limit sample creation.

## 11. PRECAUTION IN DESIGN

### 11.1 PRECAUTIONS AGAINST ELECTROSTATIC DISCHARGE

As this module contains C-MOS LSIs, it is not strong against electrostatic discharge. Make certain that the operator's body is connected to the ground through a wrist band, etc.

And don't touch I/F pins directly.

### 11.2 HANDLING PRECAUTIONS

- (1) As the adhesives used for adhering upper/lower polarizer's and frame are made of organic substances which will be deteriorated by a chemical reaction with such chemicals as acetone, toluene, ethanol and isopropyl alcohol. The following are recommended for use:

normal hexane

Please contact with us when it is necessary for you to use chemicals other than the above.

- (2) Lightly wipe to clean the dirty surface with absorbent cotton or other soft material like chamois, soaked in the recommended chemicals without scrubbing it hardly.  
Always wipe the surface horizontally or vertically. Never give a wipe in a circle. To prevent the display surface from damage and keep the appearance in good state, it is sufficient, in general, to wipe it with absorbent cotton.
- (3) Immediately wipe off saliva or water drop attached on the display area because it may cause deformation or faded color.
- (4) Foggy dew deposited on the surface may cause a damage, stain or dirt to the polarizer.  
When you need to take out the LCD module from some place at low temperature for test, etc.  
It is required to be warmed them up to temperature higher than room temperature before taking them out.
- (5) Touching the display area or I/F pins with bare hands or contaminating them are prohibited, because the stain on the display area and poor insulation between terminals are often caused by being touched with bare hands.  
(Some cosmetics are detrimental to polarizer's.)
- (6) In general, the glass is fragile so that, especially on its periphery, tends to be cracked or chipped in handling. Please not give the LCD module sharp shocks by falling, etc.
- (7) Maximum pressure to the surface must be less than  $1.96 \times 10^4$  Pa.  
And if the pressure area is less than  $1\text{cm}^2$ , maximum pressure must be less than 1.96N.
- (8) Since the metal width is narrow on these locations (see page 9-1/1), please careful with handling.



- (9) Top sheets shall be cleaned gently using a soft cloth such as those used for glasses.  
Hard wiping accumulated dust will leave scars on the surface even using a cloth.

### 11.3 OPERATION PRECAUTION

- (1) Using a LCM module beyond its maximum ratings may result in its permanent destruction.  
LCM module's should usually be used under recommended operating conditions shown in chapter 5. Exceeding any of these conditions may adversely affect its reliability.
- (2) Response time will be extremely delayed at lower temperature than the specified operating temperature range and on the other hand LCD's shows dark blue at higher temperature.  
However those phenomena do not main defects of the LCD module. Those phenomena will disappear in the specified operating temperature range.
- (3) If the display area is pushed hard during operation, some display patterns will be abnormally display.
- (4) A slight dew depositing on terminals may cause electrochemical reaction which leads to terminal open circuit. Please operate the LCD module under the relative condition of 40°C 85%RH.

### 11.4 STORAGE

In case of storing LCD module for a long period of time (for instance, for years) for the purpose of replacement use, the following precautions necessary.

- (1) Store the LCD modules in a dark place; do not expose them to sunlight or ultraviolet rays.
- (2) Keep the temperature between -30°C and 80°C at normal humidity.
- (3) Store the LCD modules in the container which is used for shipping from us.
- (4) No articles shall be left on the surface over an extended period of time.

# 12. DESIGNATION OF LOT MARK

## 12.1 LOT MARK

Lot mark is consisted of 4 digits for production lot and 6 digits for production control..

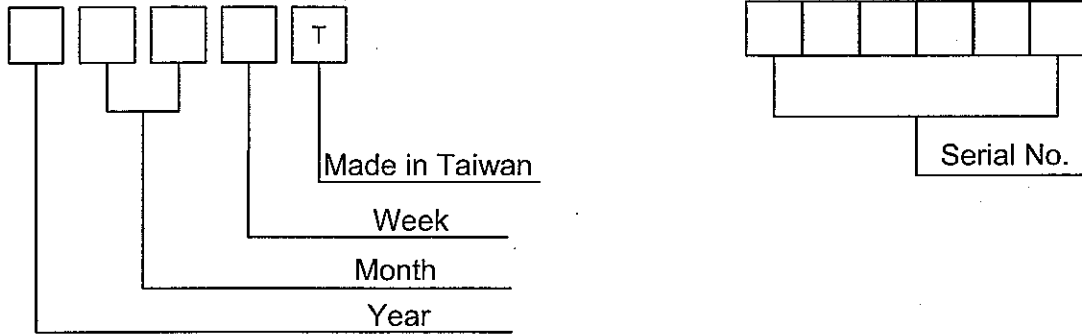

| Year | Mark |
|------|------|
| 2006 | 6    |
| 2007 | 7    |
| 2008 | 8    |
| 2009 | 9    |
| 2010 | 0    |

| Month | Jan. | Feb. | Mar. | Apr. | May  | Jun. |
|-------|------|------|------|------|------|------|
| Mark  | 01   | 02   | 03   | 04   | 05   | 06   |
| Month | Jul. | Aug. | Sep. | Oct. | Nov. | Dec. |
| Mark  | 07   | 08   | 09   | 10   | 11   | 12   |

| Week (Day In Calendar) | Figure In Lot Mark |
|------------------------|--------------------|
| 01~07                  | 1                  |
| 08~14                  | 2                  |
| 15~21                  | 3                  |
| 22~28                  | 4                  |
| 29~31                  | 5                  |

## 12.2 Location of lot mark : On the Frame

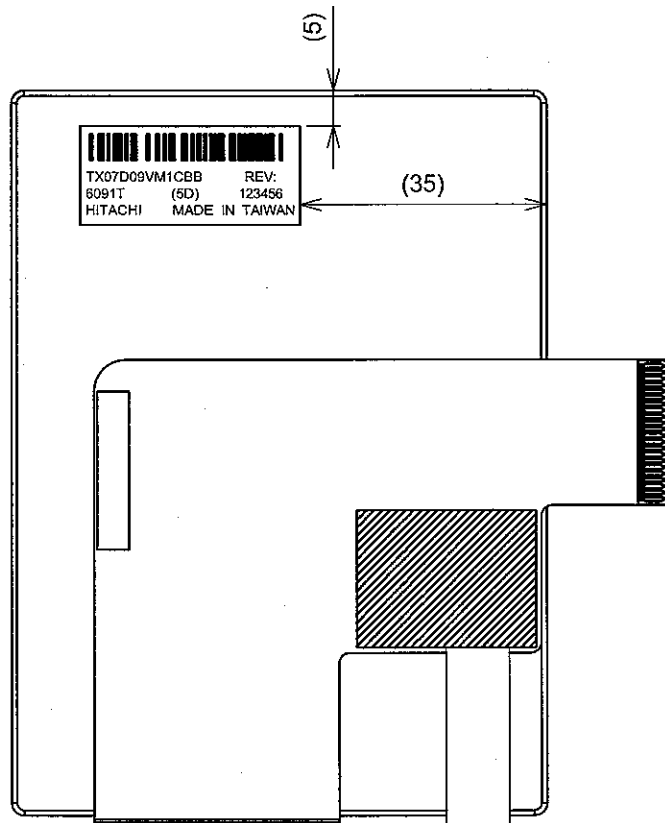

- (1) : LOT No.
- (2) : Serial No.

### 13. PRECAUTION FOR USE

(1) A limit sample should be provided by the both parties on an occasion when the both parties agree to its necessity.

Judgement by a limit sample shall take effect after the limit sample has been established and confirmed by the both parties.

(2) On the following occasions, the handling of the problem should be decided through discussion and agreement between responsible persons of the both parties.

1) When a question is arisen in the specifications.

2) When a new problem is arisen which is not specified in this specifications.

3) When an inspection specifications change or operating condition change by customer is reported to HITACHI, and some problem is arisen in the specification due to the change.

4) When a new problem is arisen at the customer's operating set for sample evaluation.

(3) Regarding the treatment for maintenance and repairing, both parties will discuss it in six months later after latest delivery of this product.

The precaution that should be observed when handling LCM have been explained above.

If any points are unclear or if you have any requests, please contact with HITACHI.

## 14. RELIABILITY TEST

| TEST ITEM                                 | CONDITION  | JUDGEMENT NOTE          |
|---|--|-------------------------|
| High Temperature and Humidity (Operation) | ● $40\pm 2^{\circ}\text{C}$ , RH=85%, 250 hours  | No display malfunctions |
| Heat Cycle (Operation)                    | ● $-20\pm 3^{\circ}\text{C}$ ...1hour, $70\pm 3^{\circ}\text{C}$ ...1 hour<br>● 30 cycles, 8 hours / cycle   |                         |
| Thermal Shock (Storage)                   | ● $-30\pm 3^{\circ}\text{C}$ ...30 minutes, $80\pm 3^{\circ}\text{C}$ ...30 minutes<br>● 100 cycles, 1 hour / cycle<br>● Temperature transition time is within 4 minutes |                         |
| High Temperature (Storage)                | ● $80\pm 3^{\circ}\text{C}$ ...100 hours   |                         |
| Low Temperature (Storage)                 | ● $-30\pm 3^{\circ}\text{C}$ ...48 hours   |                         |
| High Temperature (Operation)              | ● $70\pm 3^{\circ}\text{C}$ ...48 hours  |                         |
| Low Temperature (Operation)               | ● $-20\pm 3^{\circ}\text{C}$ ...100 hours  |                         |
| ESD (Storage)                             | ● 200pF, $0\Omega$ , $(\pm 15)\text{kV}$ , 70%RH<br>● 9 places on a panel surface<br>● 3 times each places at 1 sec interval   |                         |
| Vibration (Storage)                       | ● 5 to 100Hz, $(11.76)\text{m/s}^2$<br>● X, Y, Z direction<br>● 1 times each directions  |                         |
| Shock (Storage)                           | ● $(490)\text{m/s}^2$ , 10ms<br>● $\pm X$ , $\pm Y$ , $\pm Z$ direction<br>● 1 times each directions   |                         |

Note1 : Condensation of water is not permitted on the module.

Note2 : The module should be inspected after 1 hour storage in room conditions.