



TS461-TS462-TS464

Output Rail-to-Rail Operational Amplifiers

- High dynamic features
- Large output swing ($\pm 2.4V$ @ $V_{CC} = \pm 2.5V$)
- Low noise level: $4nV/\sqrt{Hz}$
- Low distortion: 0.003%
- Operating range: 2.7V to 10V
- Available in SOT23-5 micropackage

Description

The TS46x are a family of operational amplifiers able to operate with voltages as low as $\pm 1.35V$ and to reach a minimum of $\pm 2V_{pp}$ of output swing when supplied with $\pm 2.5V$.

This device is well-suited for all kinds of portable and battery-supplied equipment, where low noise and low distortion are key requirements.

The TS461/2/4 offer excellent output rail-to-rail performance at an attractive cost.

Applications

- Sound cards
- PDA
- CD players
- Recording equipment
- Multimedia
- Microphone preamplifiers

Pin Connections (top view)

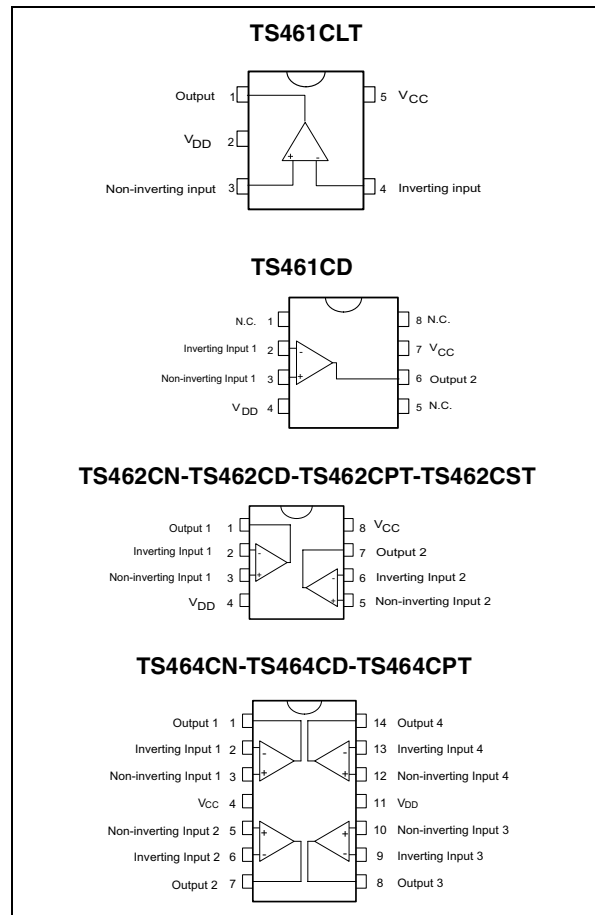

Order Codes

Part Number	Temperature Range	Package	Packaging	Marking
TS461CLT	-20°C, +70°C	SOT23-5L	Tape & Reel	K105
TS461CD/CDT		SO-8	Tube or Tape & Reel	
TS462CST		mini SO-8	Tape & Reel	
TS462CPT		TSSOP-8 (Thin Shrink Outline Package)	Tape & Reel	
TS462CN		DIP8	Tube	
TS462CD/CDT		SO-8	Tube or Tape & Reel	
TS464CPT		TSSOP-14 (Thin Shrink Outline Package)	Tape & Reel	
TS464CN		DIP14	Tube	
TS464CD/CDT		SO-14	Tube or Tape & Reel	

1 Absolute Maximum Ratings

Table 1: Key parameters and their absolute maximum ratings

Symbol	Parameter	Value	Unit
VCC	Supply voltage ¹	12	V
V _{id}	Differential Input Voltage ²	±VCC	V
V _{in}	Input Voltage Range	V _{dd} -0.3 to V _{cc} +0.3	V
T _{oper}	Operating Free Air Temperature Range	-20 to +70	°C
T _{std}	Storage Temperature Range	-65 to +150	°C
T _j	Maximum Junction Temperature	150	°C
R _{thja}	Thermal Resistance Junction to Case ³		°C/W
	SOT23-5	250	
	SO8	125	
	SO14	103	
	TSSOP8	120	
	TSSOP14	100	
ESD	HBM: Human Body Model ⁴	2	kV
	MM: Machine Model ⁵	200	V
	CDM: Charged Device Model	1.5	kV
	Lead Temperature (soldering, 10sec)	250	°C

1) All voltages values, except differential voltage are with respect to network group terminal.

2) Differential voltages are non-inverting input terminal with respect to the inverting input terminal.

3) Short-circuits can cause excessive heating and destructive dissipation.

4) Human body model, 100pF discharged through a 1.5kΩ resistor into pin of device.

5) Machine model ESD, a 200pF cap is charged to the specified voltage, then discharged directly into the IC with no external series resistor (internal resistor < 5Ω), into pin to pin of device.

Table 2: Operating conditions

Symbol	Parameter	Value	Unit
VCC	Supply Voltage	2.7 to 10	V
V _{icm}	Common Mode Input Voltage Range	V _{DD} +1.15 to V _{CC} - 1.15	V
T _{oper}	Operating Free Air Temperature Range	-20 to +70	°C

2 Electrical Characteristics

Table 3: $V_{CC} = 2.5V$, $V_{DD} = -2.5V$, $T_{amb} = 25^{\circ}C$ (unless otherwise specified)

Symbol	Parameter	Min.	Typ.	Max.	Unit
V_{io}	Input Offset Voltage $T_{min.} \leq T_{amb} \leq T_{max.}$		1	5 7	mV
ΔV_{io}	Input Offset Voltage Drift $V_{icm} = 0V, V_o = 0V$		5		$\mu V/^{\circ}C$
I_{io}	Input Offset Current $V_{icm} = 0V, V_o = 0V$ $T_{min.} \leq T_{amb} \leq T_{max.}$		10	150 200	nA
I_{ib}	Input Bias Current $V_{icm} = 0V, V_o = 0V$ $T_{min.} \leq T_{amb} \leq T_{max.}$		200 200	750 1000	nA
V_{icm}	Common Mode Input Voltage Range	-1.35		1.35	V
CMR	Common Mode Rejection Ratio $V_{icm} = \pm 1.35V$	60	85		dB
SVR	Supply Voltage Rejection Ratio $V_{cc} = \pm 2V$ to $\pm 3V$	60	70		dB
A_{vd}	Large Signal Voltage Gain $R_L = 2k\Omega$	70	80		dB
V_{OH}	High Level Output Voltage $R_L = 2k\Omega$	2	2.4		V
V_{OL}	Low Level Output Voltage $R_L = 2k\Omega$		-2.4	-2	V
I_{CC}	Supply Current, per amplifier Unity gain - no load		2	2.8	mA
GBP	Gain Bandwidth Product $f = 100kHz$ $R_L = 2k\Omega, C_L = 100pF$	8.5	12		MHz
SR	Slew Rate $A_V = 1, V_{in} = \pm 1V$	2.8	4		V/ μs
e_n	Equivalent Input Noise Voltage $f = 100kHz$		4		$\frac{nV}{\sqrt{Hz}}$
THD	Total Harmonic Distortion $f = 1kHz, A_V = -1$ $R_L = 10k\Omega$		0.003		%

3 Package Mechanical Data

3.1 SOT23-5L package

SOT23-5L MECHANICAL DATA

DIM.	mm.			mils		
	MIN.	TYP.	MAX.	MIN.	TYP.	MAX.
A	0.90		1.45	35.4		57.1
A1	0.00		0.15	0.0		5.9
A2	0.90		1.30	35.4		51.2
b	0.35		0.50	13.7		19.7
C	0.09		0.20	3.5		7.8
D	2.80		3.00	110.2		118.1
E	2.60		3.00	102.3		118.1
E1	1.50		1.75	59.0		68.8
e		0.95			37.4	
e1		1.9			74.8	
L	0.35		0.55	13.7		21.6

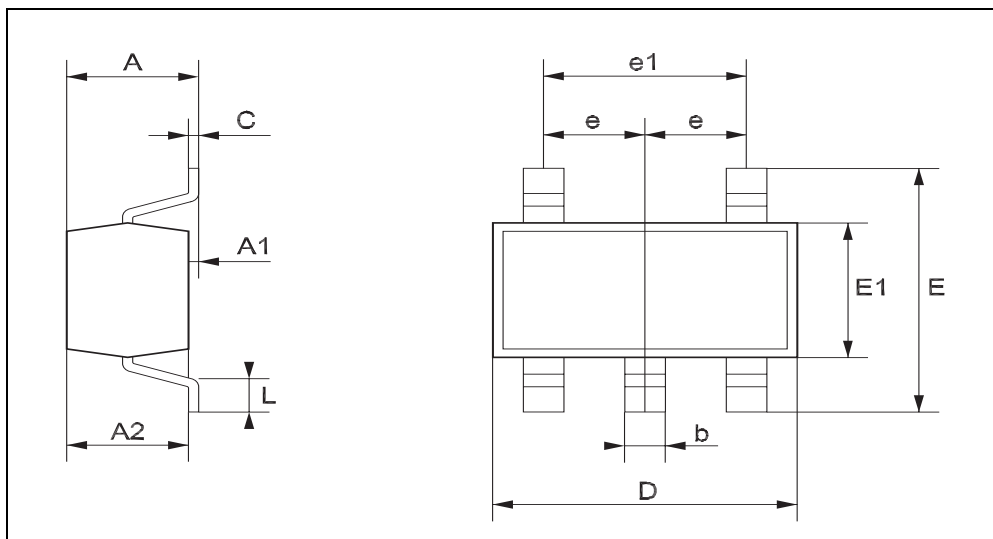

3.2 SO-8 package

SO-8 MECHANICAL DATA						
DIM.	mm.			inch		
	MIN.	TYP	MAX.	MIN.	TYP.	MAX.
A	1.35		1.75	0.053		0.069
A1	0.10		0.25	0.04		0.010
A2	1.10		1.65	0.043		0.065
B	0.33		0.51	0.013		0.020
C	0.19		0.25	0.007		0.010
D	4.80		5.00	0.189		0.197
E	3.80		4.00	0.150		0.157
e		1.27			0.050	
H	5.80		6.20	0.228		0.244
h	0.25		0.50	0.010		0.020
L	0.40		1.27	0.016		0.050
k	8° (max.)					
ddd			0.1			0.04

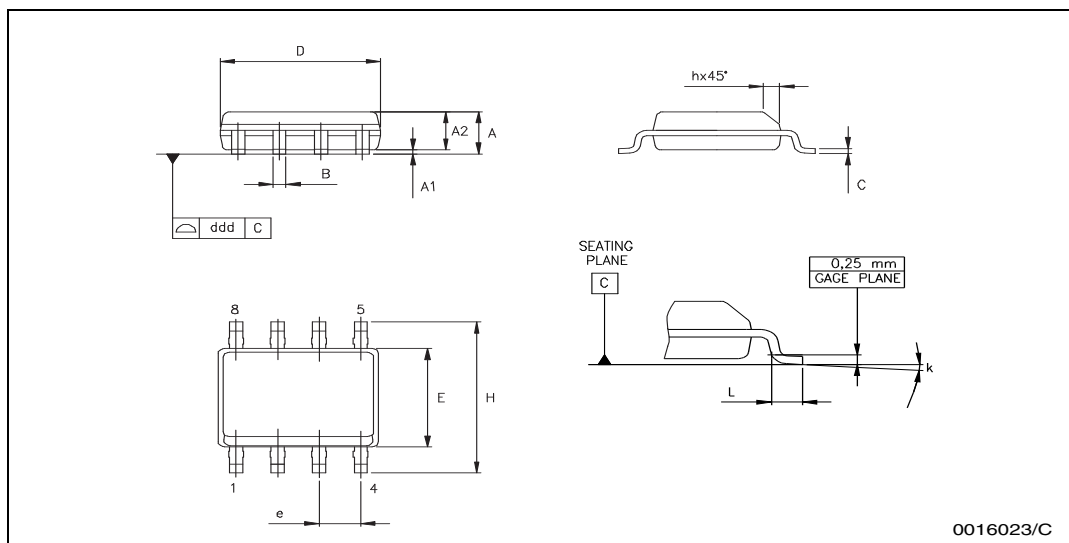

0016023/C

3.3 Mini SO-8 package

miniSO-8 MECHANICAL DATA						
DIM.	mm.			inch		
	MIN.	TYP	MAX.	MIN.	TYP.	MAX.
A			1.1			0.043
A1	0.05	0.10	0.15	0.002	0.004	0.006
A2	0.78	0.86	0.94	0.031	0.031	0.037
b	0.25	0.33	0.40	0.010	0.13	0.013
c	0.13	0.18	0.23	0.005	0.007	0.009
D	2.90	3.00	3.10	0.114	0.118	0.122
E	4.75	4.90	5.05	0.187	0.193	0.199
E1	2.90	3.00	3.10	.0114	0.118	0.122
e		0.65			0.026	
K	0°		6°	0°		6°
L	0.40	0.55	0.70	0.016	0.022	0.028
L1			0.10			0.004

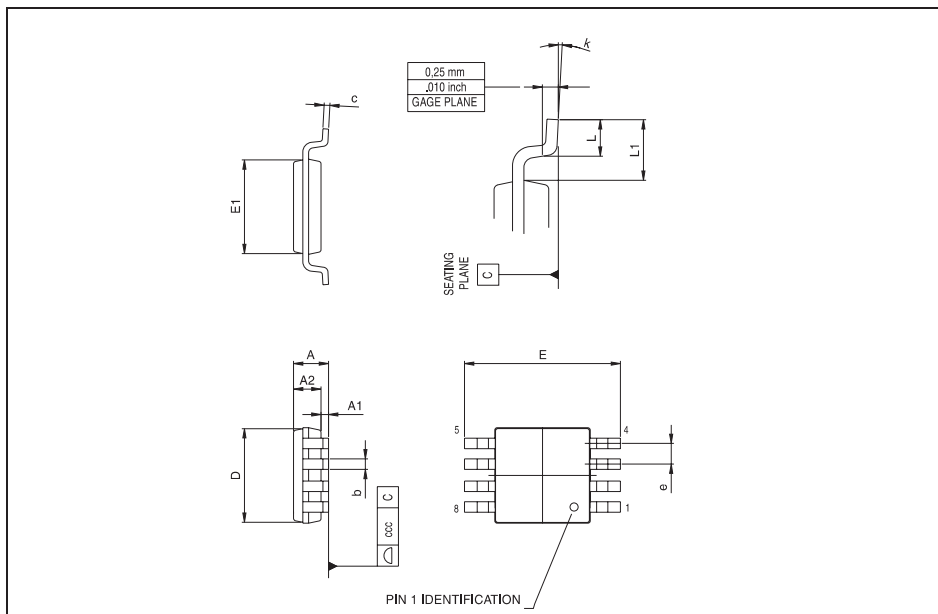

3.4 TSSOP8 package

TSSOP8 MECHANICAL DATA						
DIM.	mm.			inch		
	MIN.	TYP.	MAX.	MIN.	TYP.	MAX.
A			1.2			0.047
A1	0.05		0.15	0.002		0.006
A2	0.80	1.00	1.05	0.031	0.039	0.041
b	0.19		0.30	0.007		0.012
c	0.09		0.20	0.004		0.008
D	2.90	3.00	3.10	0.114	0.118	0.122
E	6.20	6.40	6.60	0.244	0.252	0.260
E1	4.30	4.40	4.50	0.169	0.173	0.177
e		0.65			0.0256	
K	0°		8°	0°		8°
L	0.45	0.60	0.75	0.018	0.024	0.030
L1		1			0.039	

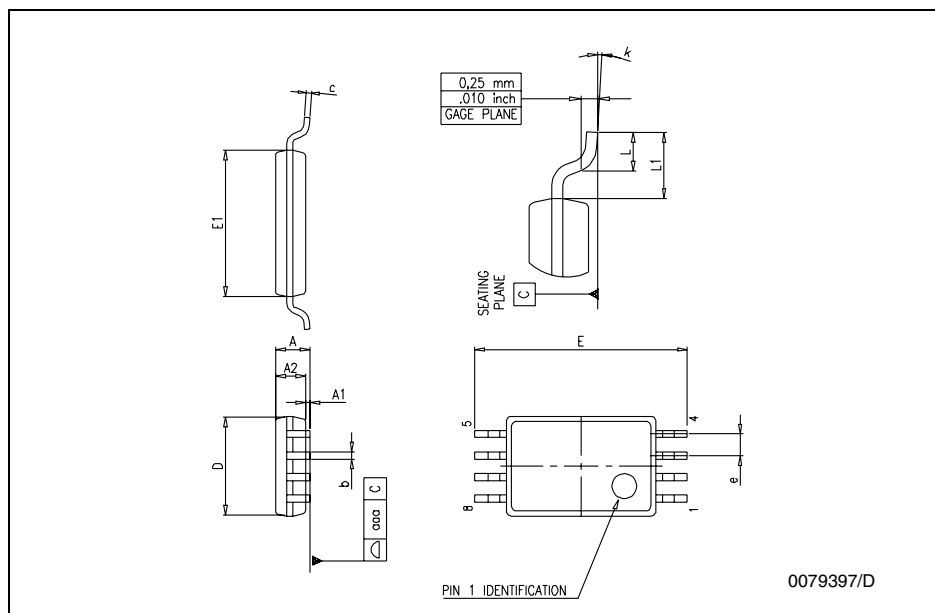

3.5 DIP8 package

Plastic DIP-8 MECHANICAL DATA

DIM.	mm.			inch		
	MIN.	TYP	MAX.	MIN.	TYP.	MAX.
A		3.3			0.130	
a1	0.7			0.028		
B	1.39		1.65	0.055		0.065
B1	0.91		1.04	0.036		0.041
b		0.5			0.020	
b1	0.38		0.5	0.015		0.020
D			9.8			0.386
E		8.8			0.346	
e		2.54			0.100	
e3		7.62			0.300	
e4		7.62			0.300	
F			7.1			0.280
l			4.8			0.189
L		3.3			0.130	
Z	0.44		1.6	0.017		0.063

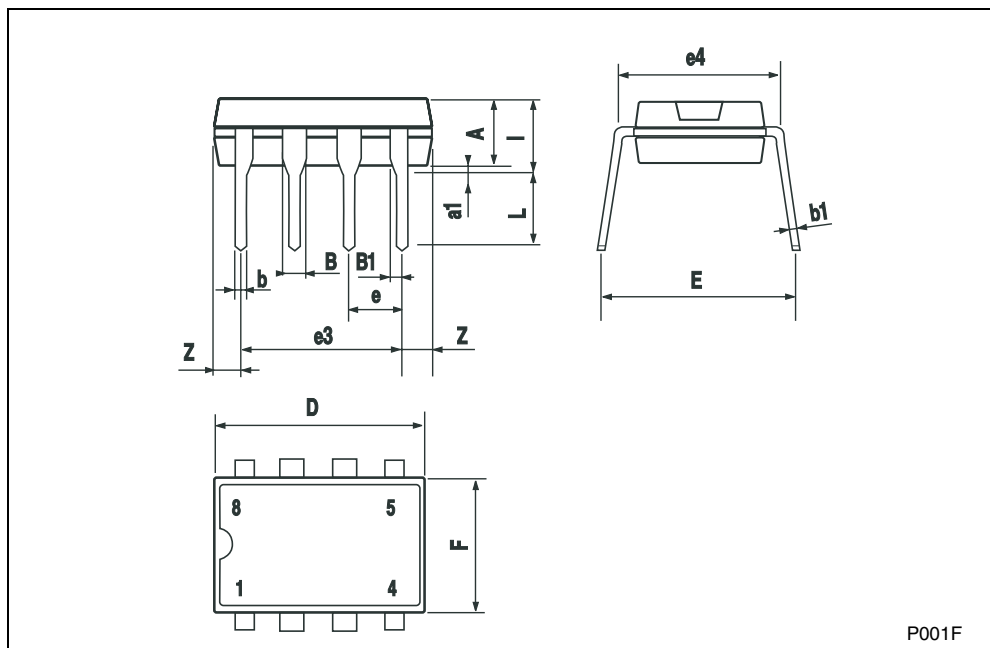

3.6 TSSOP14 package

TSSOP14 MECHANICAL DATA

DIM.	mm.			inch		
	MIN.	TYP	MAX.	MIN.	TYP.	MAX.
A			1.2			0.047
A1	0.05		0.15	0.002	0.004	0.006
A2	0.8	1	1.05	0.031	0.039	0.041
b	0.19		0.30	0.007		0.012
c	0.09		0.20	0.004		0.0089
D	4.9	5	5.1	0.193	0.197	0.201
E	6.2	6.4	6.6	0.244	0.252	0.260
E1	4.3	4.4	4.48	0.169	0.173	0.176
e		0.65 BSC			0.0256 BSC	
K	0°		8°	0°		8°
L	0.45	0.60	0.75	0.018	0.024	0.030

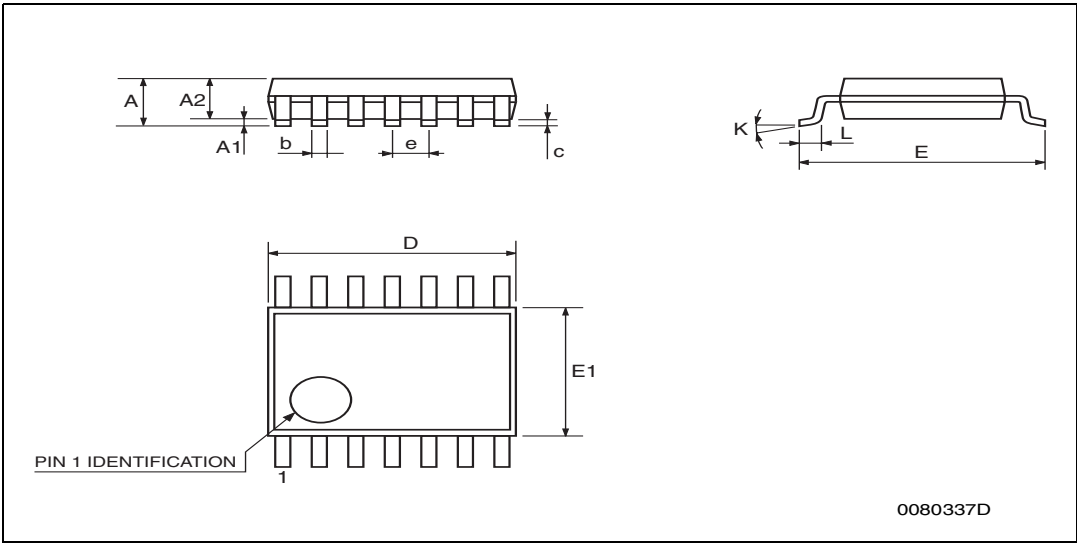

3.7 DIP14 package

Plastic DIP-14 MECHANICAL DATA

DIM.	mm.			inch		
	MIN.	TYP.	MAX.	MIN.	TYP.	MAX.
a1	0.51			0.020		
B	1.39		1.65	0.055		0.065
b		0.5			0.020	
b1		0.25			0.010	
D			20			0.787
E		8.5			0.335	
e		2.54			0.100	
e3		15.24			0.600	
F			7.1			0.280
l			5.1			0.201
L		3.3			0.130	
Z	1.27		2.54	0.050		0.100

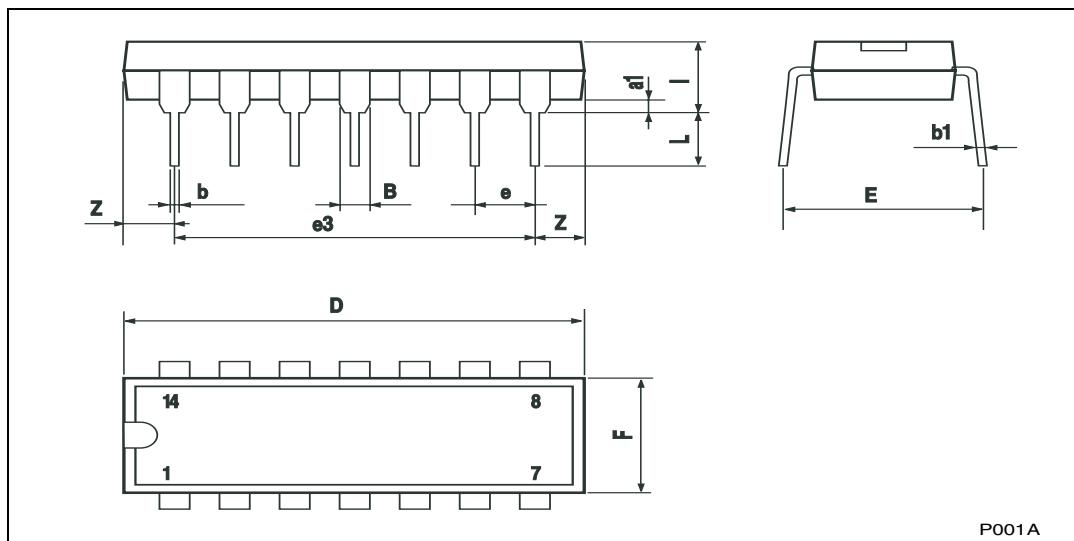

3.8 SO-14 package

SO-14 MECHANICAL DATA

DIM.	mm.			inch		
	MIN.	TYP	MAX.	MIN.	TYP.	MAX.
A			1.75			0.068
a1	0.1		0.2	0.003		0.007
a2			1.65			0.064
b	0.35		0.46	0.013		0.018
b1	0.19		0.25	0.007		0.010
C		0.5			0.019	
c1	45° (typ.)					
D	8.55		8.75	0.336		0.344
E	5.8		6.2	0.228		0.244
e		1.27			0.050	
e3		7.62			0.300	
F	3.8		4.0	0.149		0.157
G	4.6		5.3	0.181		0.208
L	0.5		1.27	0.019		0.050
M			0.68			0.026
S	B° (max.)					

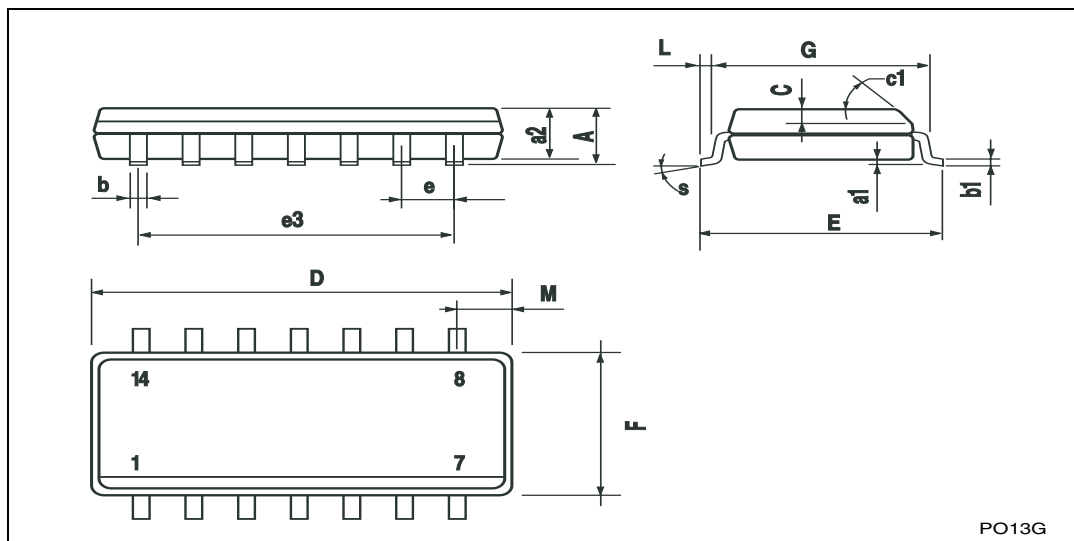

PO13G

4 Revision History

Date	Revision	Description of Changes
January 2002	1	First Release
March 2005	2	Modifications on AMR Table 1 on page 2 (explanation of Vid and Vi limits)

Information furnished is believed to be accurate and reliable. However, STMicroelectronics assumes no responsibility for the consequences of use of such information nor for any infringement of patents or other rights of third parties which may result from its use. No license is granted by implication or otherwise under any patent or patent rights of STMicroelectronics. Specifications mentioned in this publication are subject to change without notice. This publication supersedes and replaces all information previously supplied. STMicroelectronics products are not authorized for use as critical components in life support devices or systems without express written approval of STMicroelectronics.

The ST logo is a registered trademark of STMicroelectronics
All other names are the property of their respective owners

© 2005 STMicroelectronics - All rights reserved

STMicroelectronics group of companies

Australia - Belgium - Brazil - Canada - China - Czech Republic - Finland - France - Germany - Hong Kong - India - Israel - Italy - Japan - Malaysia - Malta - Morocco - Singapore - Spain - Sweden - Switzerland - United Kingdom - United States of America

www.st.com