

Rail-to-Rail High Output Current Dual Operational Amplifier

- Rail-to-rail input and output
- Low noise: $9\text{nV}/\sqrt{\text{Hz}}$
- Low distortion
- High output current: 80mA
(able to drive 32Ω loads)
- High-speed: 4MHz, $1\text{V}/\mu\text{s}$
- Operating from 2.7V to 12V
- Low input offset voltage: $900\mu\text{V}$ max (TS922A)
- ESD Internal protection: 2kV
- Latch-up immunity
- Macromodel included in this specification
- Dual version available in flip-chip package

Description

The TS922 is a rail-to-rail dual BiCMOS operational amplifier optimized and fully specified for 3V and 5V operation.

The device's high output current allows low-load impedances to be driven.

Very low noise, low distortion, low offset and a high output current capability make this device an excellent choice for high quality, low voltage or battery operated audio systems.

The device is stable for capacitive loads up to 500pF.

Applications

- Headphone amplifier
- Sound cards, multimedia systems
- Line driver, actuator driver
- Servo amplifier
- Mobile phone and portable equipment
- Instrumentation with low noise as key factor
- Piezoelectric speaker driver

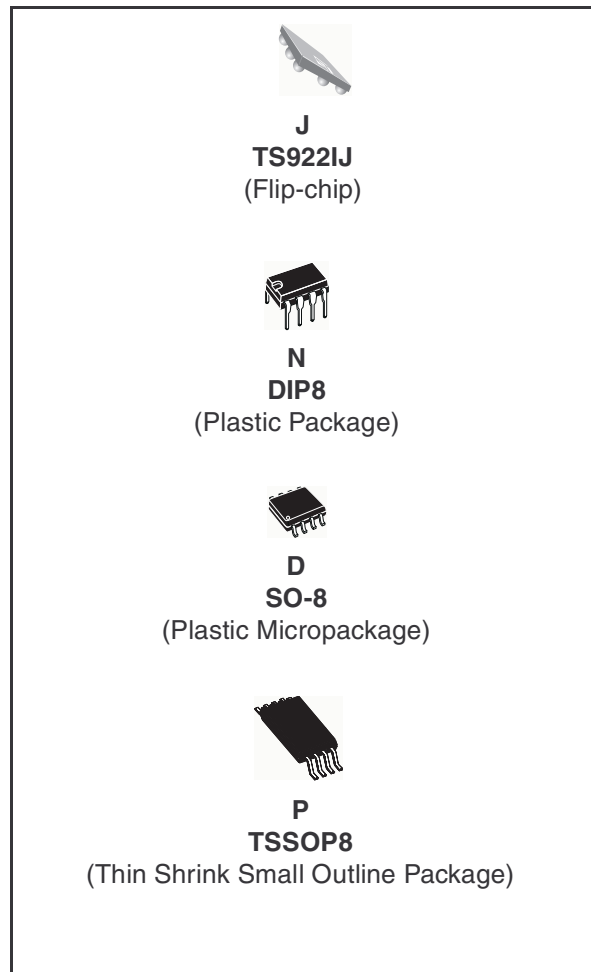

Order Codes

Part Number	Temperature Range	Package	Packaging	Marking
TS922IN	-40°C, +125°C	DIP8	Tube	TS922IN
TS922AIN				TS922AIN
TS922ID/IDT		SO-8	Tube or Tape & Reel	922I
TS922AID/AIDT				922AI
TS922IPT		TSSOP8 (Thin Shrink Outline Package)	Tape & Reel	922I
TS922AIPT				922AI
TS922IJT		Flip-Chip	Tape & Reel	922
TS922IYD/IYDT		SO-8 (automotive grade level)	Tube or Tape & Reel	922IY
TS922AIYD/AIYDT				922AIY
TS922IYPT		TSSOP8 (automotive grade level)	Tape & Reel	922IY
TS922AIYPT				922AY

1 Pin Diagrams

Figure 1. Pin connections (top view)

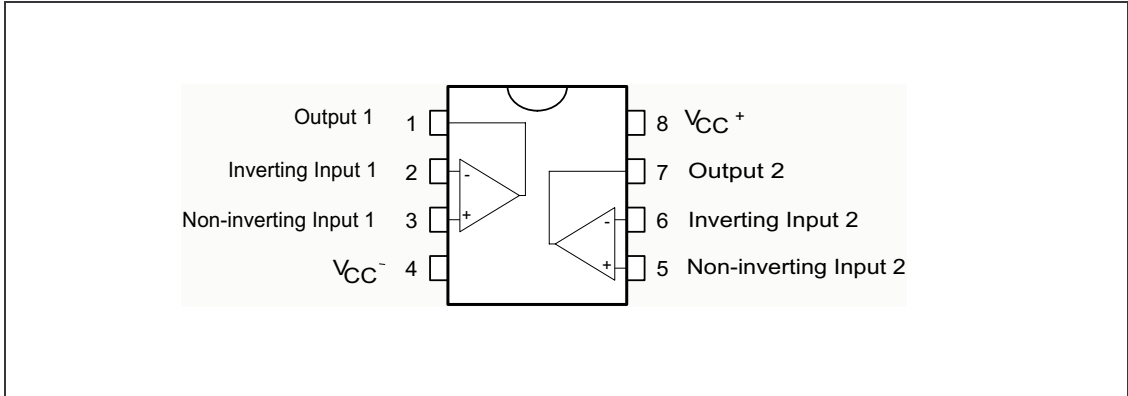
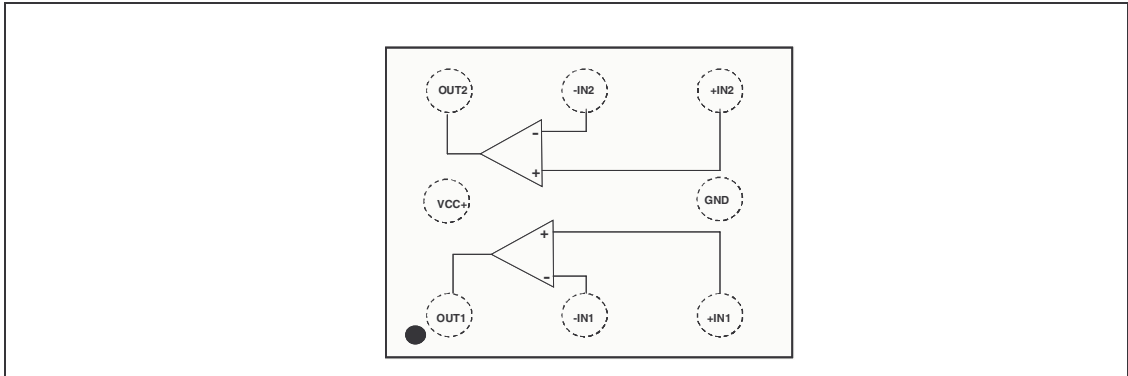

Figure 2. Pin-out for flip-chip package (top view)



2 Absolute Maximum Ratings

Table 1. Key parameters and their absolute maximum ratings

Symbol	Parameter	Value	Unit
V_{CC}	Supply voltage ⁽¹⁾	14	V
V_{id}	Differential Input Voltage ⁽²⁾	± 1	V
V_{in}	Input Voltage ⁽³⁾	$V_{DD}-0.3$ to $V_{CC}+0.3$	V
T_{stg}	Storage Temperature	-65 to +150	°C
R_{thja}	Thermal Resistance Junction to Ambient SO8	125	°C/W
	TSSOP8	120	
	DIP8	85	
	Flip Chip	90	
T_j	Maximum Junction Temperature	150	°C
ESD	HBM: Human Body Model ⁽⁴⁾	2	kV
	MM: Machine Model ⁽⁵⁾	100	V
	CDM: Charged Device Model	1.5	kV
	Output Short Circuit Duration	see note ⁽⁶⁾	
	Latch-up Immunity	200	mA
	Soldering Temperature (10sec), leaded version	250	°C
	Soldering Temperature (10sec), unleaded version	260	°C

1. All voltages values, except differential voltage are with respect to network ground terminal.
2. Differential voltages are the non-inverting input terminal with respect to the inverting input terminal. If $V_{id} > \pm 1V$, the maximum input current must not exceed $\pm 1mA$. In this case ($V_{id} > \pm 1V$) an input serie resistor must be added to limit input current.
3. Do not exceed 14V.
4. Human body model, 100pF discharged through a 1.5kΩ resistor into pin of device.
5. Machine model ESD, a 200pF cap is charged to the specified voltage, then discharged directly into the IC with no external series resistor (internal resistor < 5Ω), into pin to pin of device.
6. There is no short-circuit protection inside the device: short-circuits from the output to V_{CC} can cause excessive heating. The maximum output current is approximately 80mA, independent of the magnitude of V_{CC} . Destructive dissipation can result from simultaneous short-circuits on all amplifiers.

Table 2. Operating conditions

Symbol	Parameter	Value	Unit
V_{CC}	Supply voltage	2.7 to 12	V
V_{icm}	Common Mode Input Voltage Range	$V_{DD} - 0.2$ to $V_{CC} + 0.2$	V
T_{oper}	Operating Free Air Temperature Range	-40 to +125	°C

3 Electrical Characteristics

Table 3. $V_{CC} = +3V$, $V_{DD} = 0V$, $V_{icm} = V_{CC}/2$, $T_{amb} = 25^{\circ}C$, R_L connected to $V_{CC}/2$ (unless otherwise specified)

Symbol	Parameter	Min.	Typ.	Max.	Unit
V_{io}	Input Offset Voltage TS922			3	mV
	Input Offset voltage TS922A			0.9	
	Input Offset Voltage TS922IJ (Flip Chip)			1.5	
	$T_{min.} \leq T_{amb} \leq T_{max.}$ TS922			5	
	$T_{min.} \leq T_{amb} \leq T_{max.}$ TS922A			1.8	
	$T_{min.} \leq T_{amb} \leq T_{max.}$ TS922IJ (Flip Chip)			2.5	
DV_{io}	Input Offset Voltage Drift		2		$\mu V/^{\circ}C$
I_{io}	Input Offset Current - $V_{out} = V_{CC}/2$		1	30	nA
I_{ib}	Input Bias Current $V_{out} = V_{CC}/2$		15	100	nA
V_{OH}	High Level Output Voltage				V
	$R_L = 10k$	2.90			
	$R_L = 600\Omega$	2.87	2.63		
	$R_L = 32\Omega$				
V_{OL}	Low Level Output Voltage				mV
	$R_L = 10k$			50	
	$R_L = 600\Omega$		180	100	
	$R_L = 32\Omega$				
A_{vd}	Large Signal Voltage Gain ($V_{out} = 2V_{pk-pk}$)				V/mV
	$R_L = 10k$		200		
	$R_L = 600\Omega$		35		
	$R_L = 32\Omega$		16		
I_{CC}	Total Supply Current - no load, $V_{out} = V_{CC}/2$		2	3	mA
GBP	Gain Bandwidth Product - ($R_L = 600\Omega$)		4		MHz
CMR	Common Mode Rejection Ratio	60	80		dB
SVR	Supply Voltage Rejection Ratio - $V_{CC} = 2.7$ to $3.3V$	60	85		dB
I_o	Output Short Circuit Current	50	80		mA
SR	Slew Rate	0.7	1.3		$V/\mu s$
ϕ_m	Phase Margin at Unit Gain - $R_L = 600\Omega$, $C_L = 100pF$		68		Degrees
G_m	Gain Margin - $R_L = 600\Omega$, $C_L = 100pF$		12		dB
e_n	Equivalent Input Noise Voltage - $f = 1kHz$		9		$\frac{nV}{\sqrt{Hz}}$
THD	Total Harmonic Distortion $V_{out} = 2V_{pk-pk}$, $F = 1kHz$, $A_v = 1$, $R_L = 600\Omega$		0.005		%
C_s	Channel Separation		120		dB

Table 4. Electrical characteristics $V_{CC} = 5V$, $V_{DD} = 0V$, $V_{icm} = V_{cc}/2$, $T_{amb} = 25^{\circ}C$, R_L connected to $V_{cc}/2$ (unless otherwise specified)

Symbol	Parameter	Min.	Typ.	Max.	Unit
V_{io}	Input Offset Voltage TS922			3	mV
	Input Offset voltage TS922A			0.9	
	Input Offset Voltage TS922IJ (Flip Chip)			1.5	
	$T_{min.} \leq T_{amb} \leq T_{max.}$ TS922			5	
	TS922A			1.8	
V_{io}	Input Offset Voltage TS922IJ (flip chip)			1.5	mV
	$T_{min.} \leq T_{amb} \leq T_{max.}$ TS922IJ			2.5	
DV_{io}	Input Offset Voltage Drift		2		$\mu V/^{\circ}C$
I_{io}	Input Offset Current - $V_{out} = V_{cc}/2$		1	30	nA
I_{ib}	Input Bias Current - $V_{out} = V_{cc}/2$		15	100	nA
V_{OH}	High Level Output Voltage				V
	$R_L = 10k$	4.90			
	$R_L = 600\Omega$	4.85	4.4		
V_{OL}	Low Level Output Voltage				mV
	$R_L = 10k$			50	
	$R_L = 600\Omega$		300	120	
A_{vd}	Large Signal Voltage Gain ($V_{out} = 2V_{pk-pk}$)				V/mV
	$R_L = 10k$		200		
	$R_L = 600\Omega$		35		
I_{cc}	Total Supply Current - no load, $V_{out} = V_{cc}/2$		2	3	mA
GBP	Gain Bandwidth Product - ($R_L = 600\Omega$)		4		MHz
CMR	Common Mode Rejection Ratio	60	80		dB
SVR	Supply Voltage Rejection Ratio - $V_{cc} = 4.5$ to $5.5V$	60	85		dB
I_o	Output Short Circuit Current	50	80		mA
SR	Slew Rate	0.7	1.3		$V/\mu s$
ϕ_m	Phase Margin at Unit Gain - $R_L = 600\Omega$, $C_L = 100pF$		68		Degrees
G_m	Gain Margin - $R_L = 600\Omega$, $C_L = 100pF$		12		dB
e_n	Equivalent Input Noise Voltage - $f = 1kHz$		9		$\frac{nV}{\sqrt{Hz}}$
THD	Total Harmonic Distortion $V_{out} = 2V_{pk-pk}$, $F = 1kHz$, $A_v = 1$, $R_L = 600\Omega$		0.005		%
C_s	Channel Separation		120		dB

Table 5. Electrical characteristics for $V_{CC} = 3V$, $V_{DD} = 0V$, R_L , C_L connected to $V_{CC}/2$, $T_{amb} = 25^\circ C$ (unless otherwise specified)

Symbol	Conditions	Value	Unit
V_{io}		0	mV
A_{vd}	$R_L = 10k\Omega$	200	V/mV
I_{CC}	No load, per operator	1.2	mA
V_{icm}		-0.2 to 3.2	V
V_{OH}	$R_L = 10k\Omega$	2.95	V
V_{OL}	$R_L = 10k\Omega$	25	mV
I_{sink}	$V_O = 3V$	80	mA
I_{source}	$V_O = 0V$	80	mA
GBP	$R_L = 600k\Omega$	4	MHz
SR	$R_L = 10k\Omega$, $C_L = 100pF$	1.3	V/ μs
ϕ_m	$R_L = 600k\Omega$	68	Degrees

Figure 3. Output short circuit current vs. output voltage

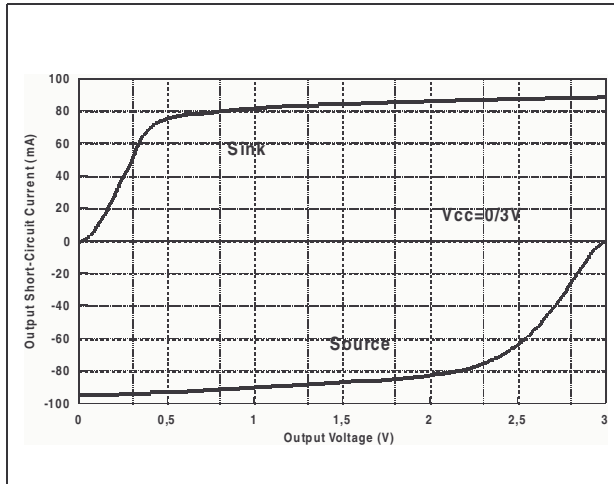

Figure 4. Total supply current vs. supply voltage

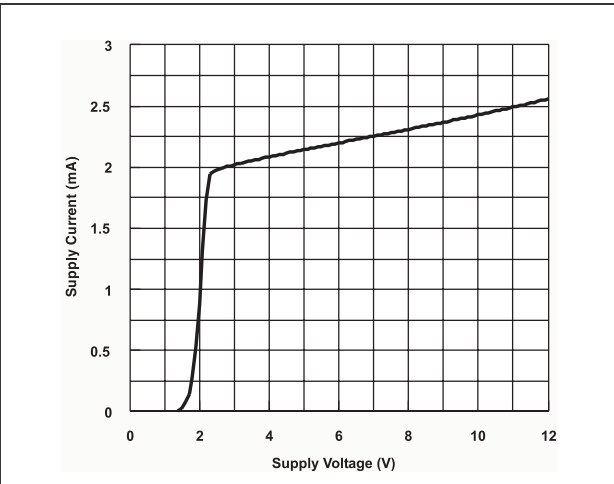

Figure 5. Voltage gain and phase vs. frequency

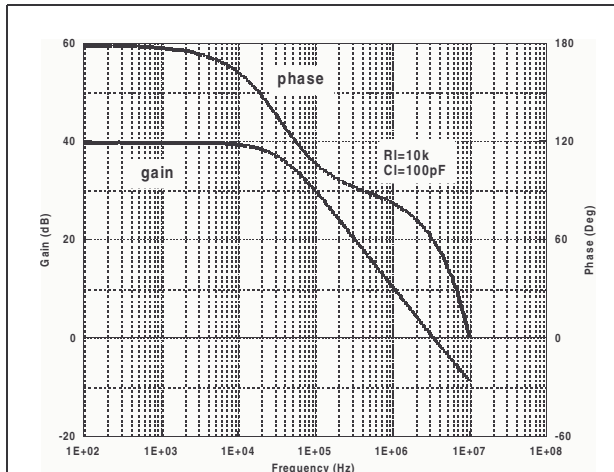

Figure 6. Equivalent input noise voltage vs. frequency

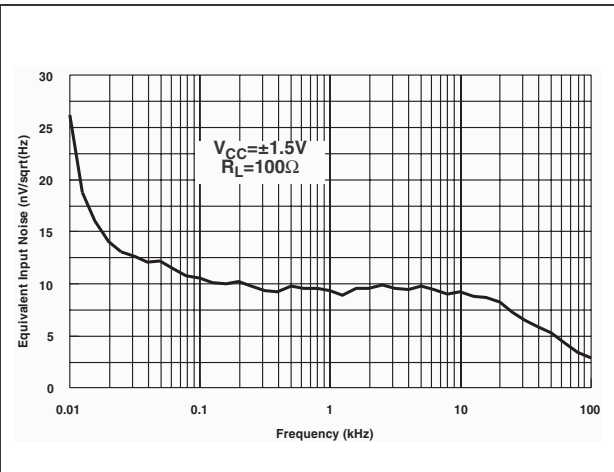

Figure 7. THD + noise vs. frequency

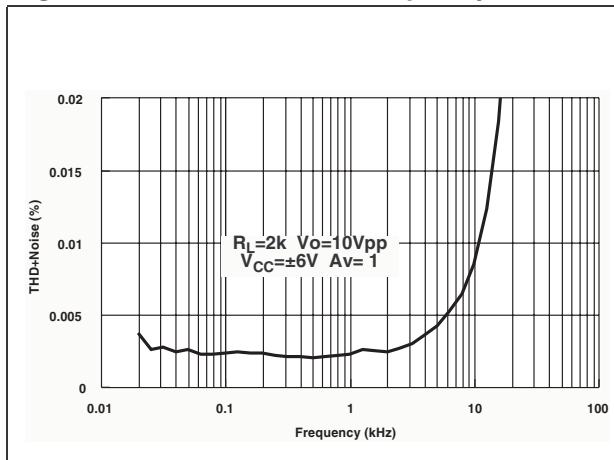

Figure 8. THD + noise vs. frequency

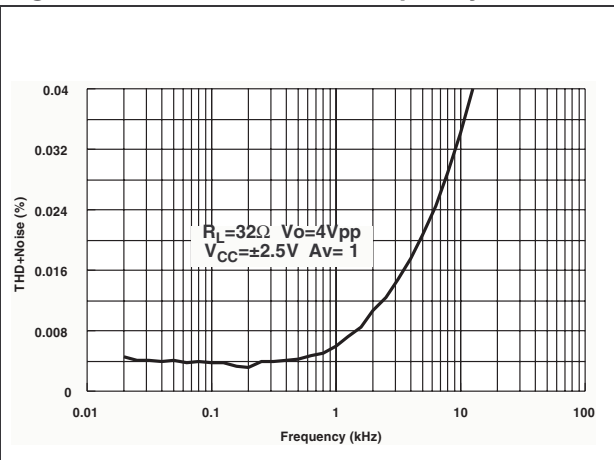

Figure 9. THD + noise vs. frequency

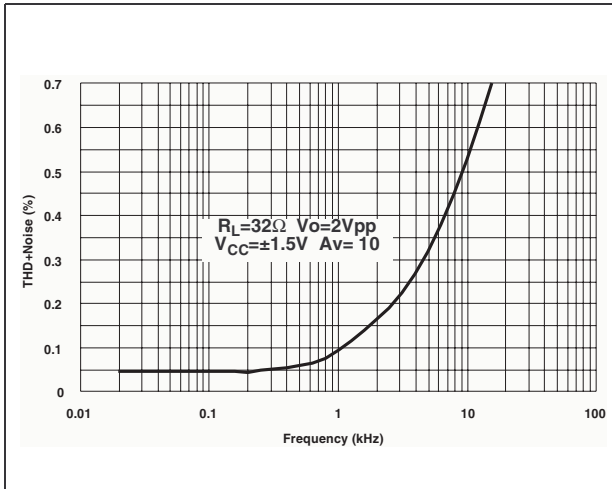

Figure 10. THD + noise vs. output voltage

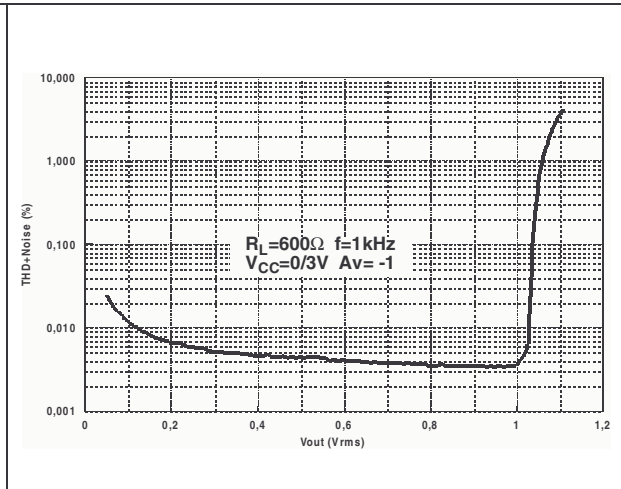

Figure 11. THD + noise vs. output voltage

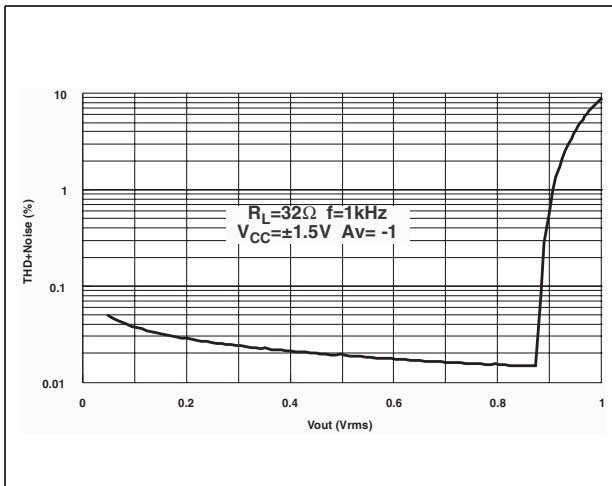

Figure 12. THD + noise vs. output voltage

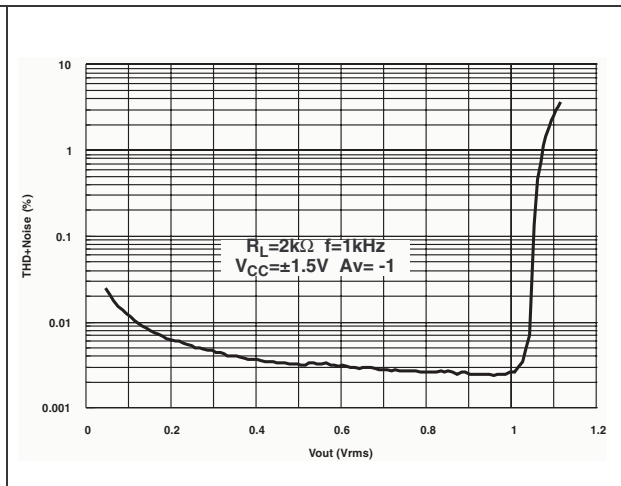
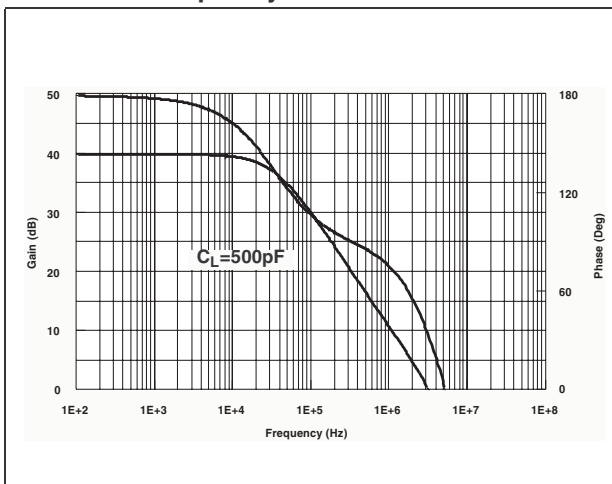

Figure 13. Open loop gain and phase vs. frequency



4 Macromodel

Note: *Please consider following remarks before using this macromodel:*

All models are a trade-off between accuracy and complexity (i.e. simulation time).

Macromodels are not a substitute to breadboarding; rather, they confirm the validity of a design approach and help to select surrounding component values.

A macromodel emulates the NOMINAL performance of a TYPICAL device within SPECIFIED OPERATING CONDITIONS (i.e. temperature, supply voltage, etc.). Thus the macromodel is often not as exhaustive as the datasheet, its goal is to illustrate the main parameters of the product.

Data issued from macromodels used outside of its specified conditions (Vcc, Temperature, etc) or even worse: outside of the device operating conditions (Vcc, Vicm, etc) are not reliable in any way.

```
** Standard Linear Ics Macromodels, 1996.
** CONNECTIONS:
* 1 INVERTING INPUT
* 2 NON-INVERTING INPUT
* 3 OUTPUT
* 4 POSITIVE POWER SUPPLY
* 5 NEGATIVE POWER SUPPLY
*
.SUBCKT TS92X 1 2 3 4 5
*
.MODEL MDTH D IS=1E-8 KF=2.664234E-16 CJO=10F
*
* INPUT STAGE
CIP 2 5 1.000000E-12
CIN 1 5 1.000000E-12
EIP 10 5 2 5 1
EIN 16 5 1 5 1
RIP 10 11 8.125000E+00
RIN 15 16 8.125000E+00
RIS 11 15 2.238465E+02
DIP 11 12 MDTH 400E-12
DIN 15 14 MDTH 400E-12
VOFP 12 13 DC 153.5u
VOFN 13 14 DC 0
IPOL 13 5 3.200000E-05
CPS 11 15 1e-9
DINN 17 13 MDTH 400E-12
VIN 17 5 -0.100000e+00
DINR 15 18 MDTH 400E-12
VIP 4 18 0.400000E+00
FCP 4 5 VOFP 1.865000E+02
FCN 5 4 VOFN 1.865000E+02
FIBP 2 5 VOFP 6.250000E-03
FIBN 5 1 VOFN 6.250000E-03
* GM1 STAGE *****
FGM1P 119 5 VOFP 1.1
FGM1N 119 5 VOFN 1.1
```

```

RAP 119 4 2.6E+06
RAN 119 5 2.6E+06
* GM2 STAGE *****
G2P 19 5 119 5 1.92E-02
G2N 19 5 119 4 1.92E-02
R2P 19 4 1E+07
R2N 19 5 1E+07
*****
VINT1 500 0 5
GCONVP 500 501 119 4 19.38
VP 501 0 0
GCONVN 500 502 119 5 19.38
VN 502 0 0
***** orientation isink isource *****
VINT2 503 0 5
FCOPY 503 504 VOUT 1
DCOPYP 504 505 MDTH 400E-9
VCOPYP 505 0 0
DCOPYN 506 504 MDTH 400E-9
VCOPYN 0 506 0
*****
F2PP 19 5 poly(2) VCOYP VP 0 0 0 0 0.5
F2PN 19 5 poly(2) VCOYP VN 0 0 0 0 0.5
F2NP 19 5 poly(2) VCOYP VP 0 0 0 0 1.75
F2NN 19 5 poly(2) VCOYP VN 0 0 0 0 1.75
* COMPENSATION *****
CC 19 119 25p
* OUTPUT *****
DOPM 19 22 MDTH 400E-12
DONM 21 19 MDTH 400E-12
HOPM 22 28 VOUT 6.250000E+02
VIPM 28 4 5.000000E+01
HONM 21 27 VOUT 6.250000E+02
VINM 5 27 5.000000E+01
VOUT 3 23 0
ROUT 23 19 6
COUT 3 5 1.300000E-10
DOP 19 25 MDTH 400E-12
VOP 4 25 1.052
DON 24 19 MDTH 400E-12
VON 24 5 1.052
.ENDS;TS92X

```

5 Package Mechanical Data

In order to meet environmental requirements, ST offers these devices in ECOPACK® packages. These packages have a Lead-free second level interconnect. The category of second level interconnect is marked on the package and on the inner box label, in compliance with JEDEC Standard JESD97. The maximum ratings related to soldering conditions are also marked on the inner box label. ECOPACK is an ST trademark. ECOPACK specifications are available at: www.st.com.

5.1 Flip-chip package (8 bumps) - TS922IJ

Figure 14. Top view and dimensions of 8-bump flip-chip

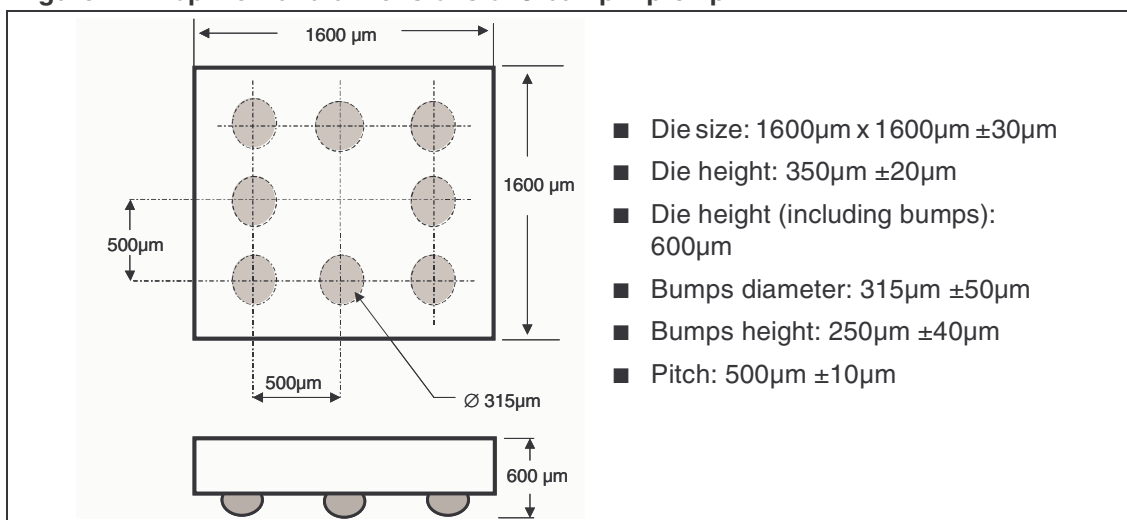

Figure 15. Flip-chip Footprint recommendation

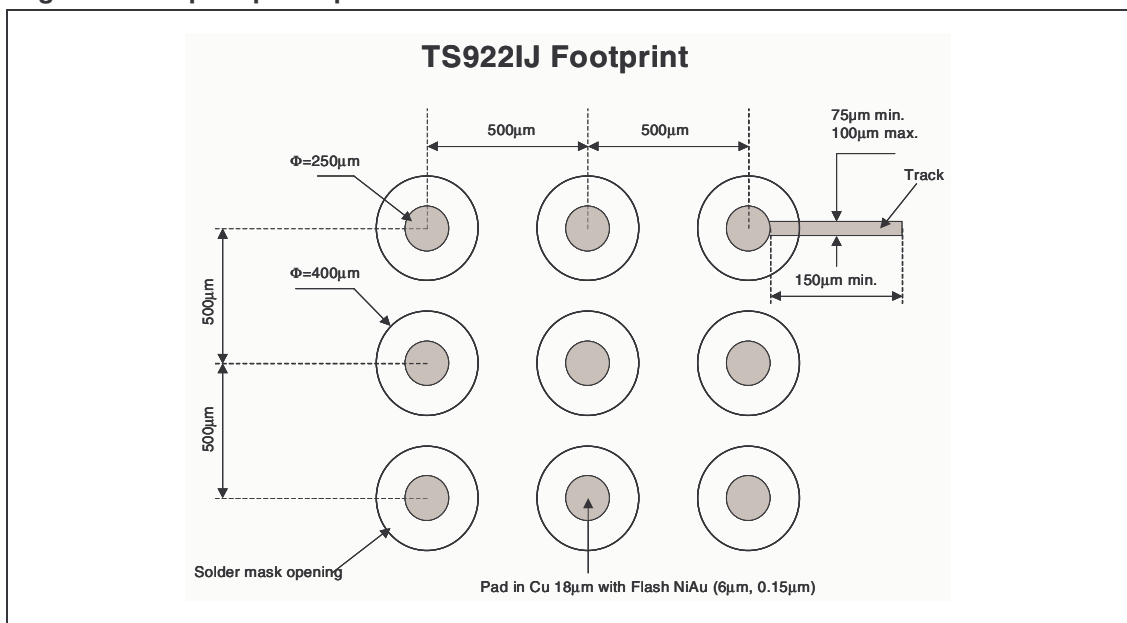

Figure 16. Flip-chip marking (top view)

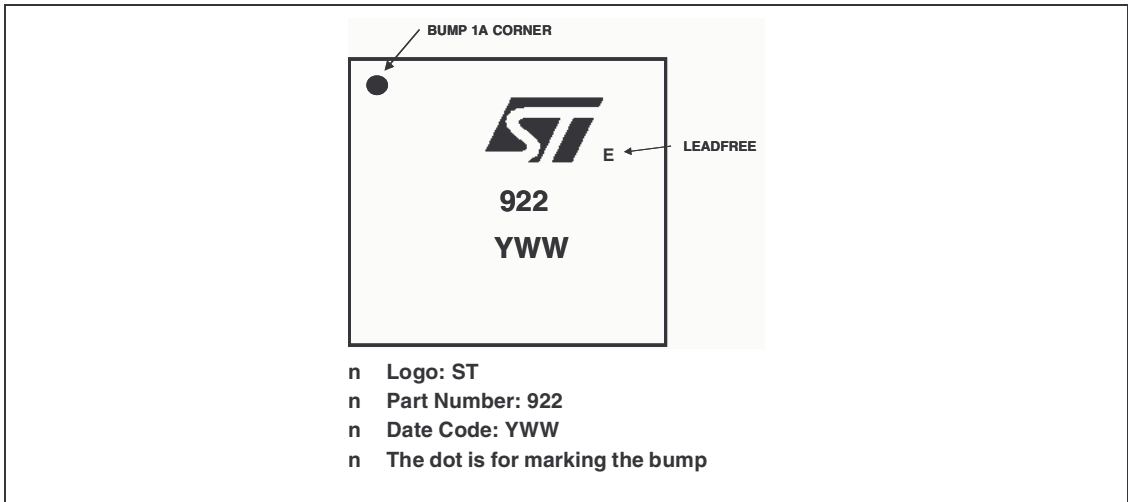
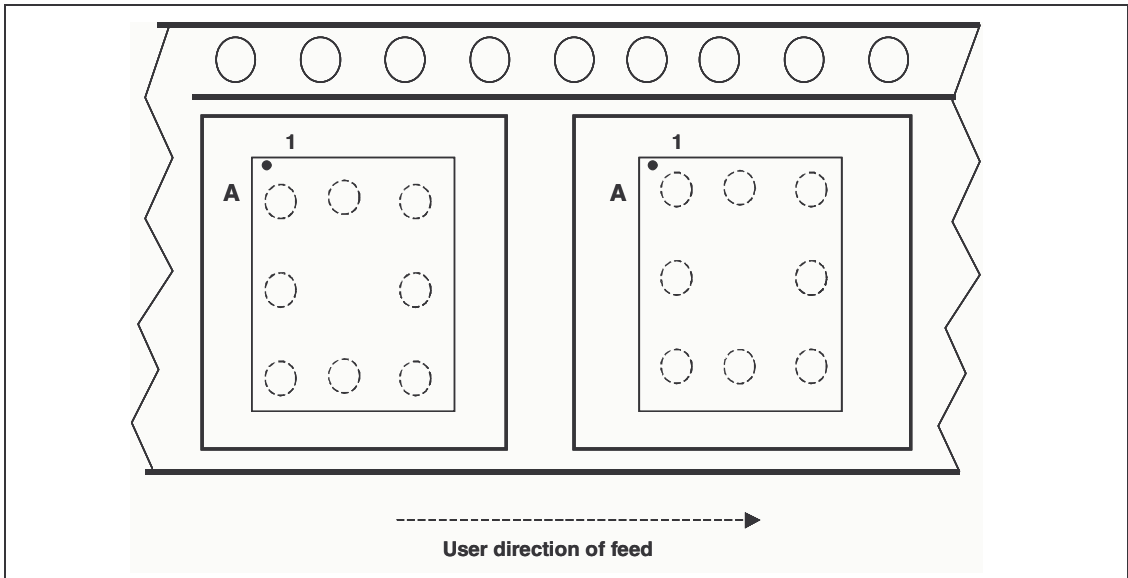

Figure 17. Tape & Reel specification (top view)



Note: **Device Orientation:** The devices are oriented in the carrier pocket with bump number A1 adjacent to the sprocket holes.

5.2 DIP8 package

Plastic DIP-8 MECHANICAL DATA						
DIM.	mm.			inch		
	MIN.	TYP.	MAX.	MIN.	TYP.	MAX.
A		3.3			0.130	
a1	0.7			0.028		
B	1.39		1.65	0.055		0.065
B1	0.91		1.04	0.036		0.041
b		0.5			0.020	
b1	0.38		0.5	0.015		0.020
D			9.8			0.386
E		8.8			0.346	
e		2.54			0.100	
e3		7.62			0.300	
e4		7.62			0.300	
F			7.1			0.280
I			4.8			0.189
L		3.3			0.130	
Z	0.44		1.6	0.017		0.063

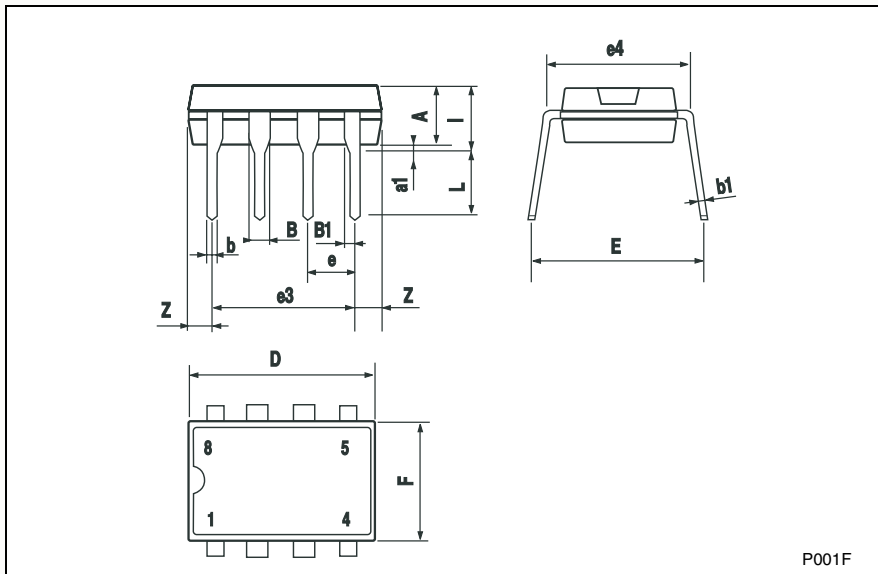

5.3 SO-8 package

SO-8 MECHANICAL DATA						
DIM.	mm.			inch		
	MIN.	TYP.	MAX.	MIN.	TYP.	MAX.
A	1.35		1.75	0.053		0.069
A1	0.10		0.25	0.04		0.010
A2	1.10		1.65	0.043		0.065
B	0.33		0.51	0.013		0.020
C	0.19		0.25	0.007		0.010
D	4.80		5.00	0.189		0.197
E	3.80		4.00	0.150		0.157
e		1.27			0.050	
H	5.80		6.20	0.228		0.244
h	0.25		0.50	0.010		0.020
L	0.40		1.27	0.016		0.050
k	8° (max.)					
ddd			0.1			0.04

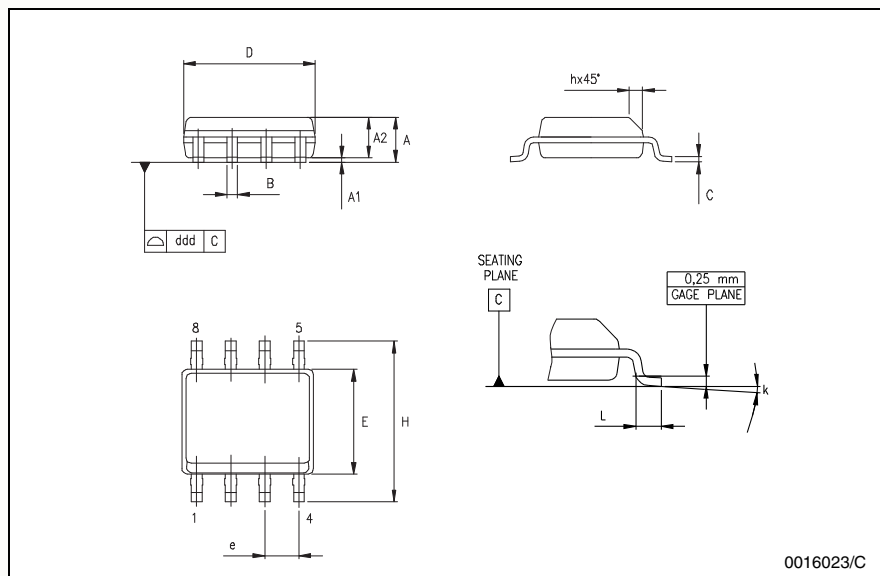

5.4 TSSOP8 package

TSSOP8 MECHANICAL DATA						
DIM.	mm.			inch		
	MIN.	TYP.	MAX.	MIN.	TYP.	MAX.
A			1.2			0.047
A1	0.05		0.15	0.002		0.006
A2	0.80	1.00	1.05	0.031	0.039	0.041
b	0.19		0.30	0.007		0.012
c	0.09		0.20	0.004		0.008
D	2.90	3.00	3.10	0.114	0.118	0.122
E	6.20	6.40	6.60	0.244	0.252	0.260
E1	4.30	4.40	4.50	0.169	0.173	0.177
e		0.65			0.0256	
K	0°		8°	0°		8°
L	0.45	0.60	0.75	0.018	0.024	0.030
L1		1			0.039	

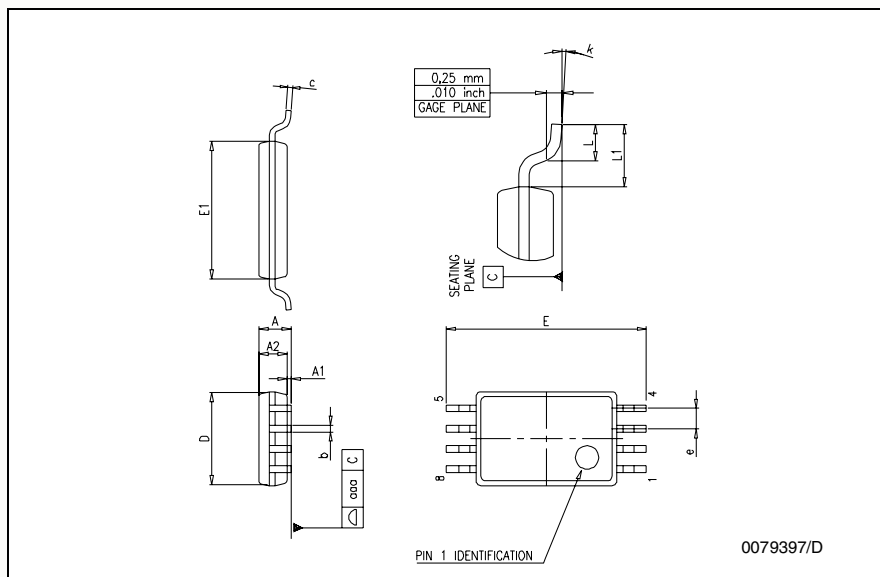

6 Revision History

Date	Revision	Changes
Feb.2001	1	First Release.
July 2004	2	Flip-Chip package inserted in the document.
May 2005	3	Modifications on AMR <i>Table 2 on page 4</i> (explanation of Vid and Vi limits, ESD MM and CDM values added, Rthja added).
Aug. 2005	4	PPAP references inserted in the datasheet see <i>Table on page 2</i> .

Information furnished is believed to be accurate and reliable. However, STMicroelectronics assumes no responsibility for the consequences of use of such information nor for any infringement of patents or other rights of third parties which may result from its use. No license is granted by implication or otherwise under any patent or patent rights of STMicroelectronics. Specifications mentioned in this publication are subject to change without notice. This publication supersedes and replaces all information previously supplied. STMicroelectronics products are not authorized for use as critical components in life support devices or systems without express written approval of STMicroelectronics.

The ST logo is a registered trademark of STMicroelectronics.
All other names are the property of their respective owners

© 2005 STMicroelectronics - All rights reserved

STMicroelectronics group of companies

Australia - Belgium - Brazil - Canada - China - Czech Republic - Finland - France - Germany - Hong Kong - India - Israel - Italy - Japan - Malaysia - Malta - Morocco - Singapore - Spain - Sweden - Switzerland - United Kingdom - United States of America

www.st.com