

IN-LINE SHUTOFF VALVE Series "V2V L" and "V3V L"

V2V L and V3V L shutoff valves belong to the LINE ON LINE® family which means they can be connected to all the other components in series or in parallel.

Available in the version for pipe-pipe connection with two FOX push-in fittings, and in the version for thread-pipe connection with a brass nickel-plated male thread and a push-in fitting.

V2V is a two-way unidirectional valve, while V3V is a three-way valve with free discharge in the area around the control knob.

The locked version is probably the smallest available on the market. A lock is provided to ensure the valve is kept in the closed position during machine maintenance. The valve is supplied complete with a lock and two keys.



TECHNICAL DATA		Ø 6	Ø 8
Operating pressure	MPa	1	
	bar	10	
	psi	145	
Temperature range	°C	-20°C to +60°C	
	°F	-4°F to +140°F	
Inlet Flow rate at 6.3 bar ΔP 1 bar	NI/min	280	470
Exhaust Flow rate 6.3 bar	NI/min	110	110
Recommended pipe Fluid		Rilsan PA 11 – Nylon 6 – Polyamide 12 – Polypropylene lubricated or unlubricated filtered compressed air; if used, must be continuous	

COMPONENT PARTS

- ① Technopolymer body
- ② Nickel-plated brass insert
- ③ Brass rod
- ④ Technopolymer knob
- ⑤ NBR valve
- ⑥ Stainless steel valve compression spring
- ⑦ Nickel-plated brass wall-mount ring nut
- ⑧ NBR gasket
- ⑨ Technopolymer spring ring
- ⑩ Stainless steel folding spring
- ⑪ Technopolymer locking bushing
- ⑫ Technopolymer release bushing

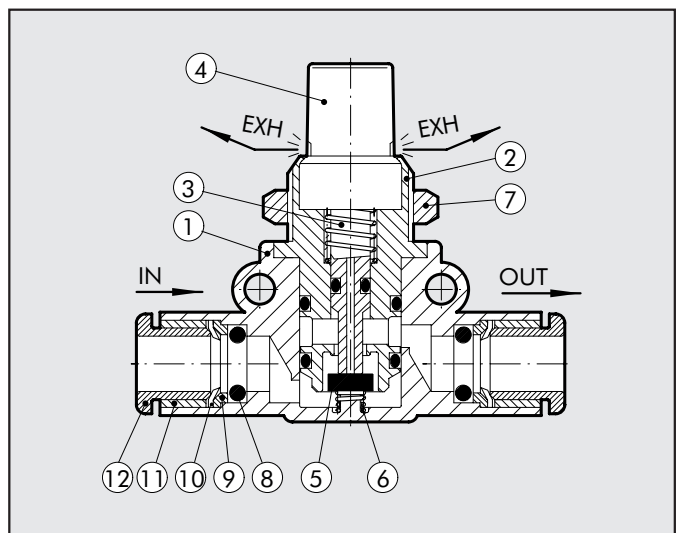

AS

Ø A B

	V2V L 6-6	6	47	41
	V3V L 6-6			
6024	V2V L 8-8	8	55.5	46
6024	V3V L 8-8			



V2V/V3V L THREAD-PIPE

Code	Ref.	F	Ø	P	A	A1	B	C	D	E	E1	G	H	I	II	Ch	Ch1	Nmax
------	------	---	---	---	---	----	---	---	---	---	----	---	---	---	----	----	-----	------

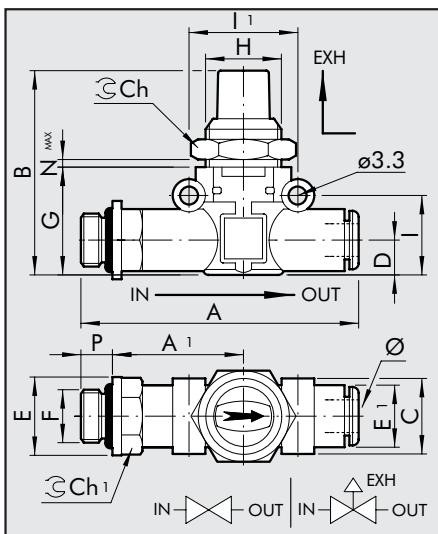

9065408	V2V L 1/8-6	1/8	6	6	57.3	27.8	41	14.7	6.4	14	11.4	21	M15x1	14.6	20	17	12	5.5
9066408	V3V L 1/8-6																	
9065409	V2V L 1/4-6	1/4	6	8	60.3	28.8	41	14.7	6.4	18	11.4	21	M15x1	14.6	20	17	14	5.5
9066409	V3V L 1/4-6																	
9065410	V2V L 1/8-8	1/8	8	6	65.3	31.8	46	18.7	9.1	15	13.8	26	M15x1	18.7	24	17	14	5.5
9066410	V3V L 1/8-8																	
9065411	V2V L 1/4-8	1/4	8	8	69.7	34.2	46	18.7	9.1	18	13.8	26	M15x1	18.7	24	17	14	5.5
9066411	V3V L 1/4-8																	
9065412	V2V L 3/8-8	3/8	8	9	71.3	34.8	46	18.7	9.1	22	13.8	26	M15x1	18.7	24	17	17	5.5
9066412	V3V L 3/8-8																	

V2V/V3V L THREAD-PIPE PADLOCKED

Code	Ref.	F	Ø	P	A	A1	B	C	D	E	E1	G	H	I	II	Ch	Ch1	Nmax
------	------	---	---	---	---	----	---	---	---	---	----	---	---	---	----	----	-----	------

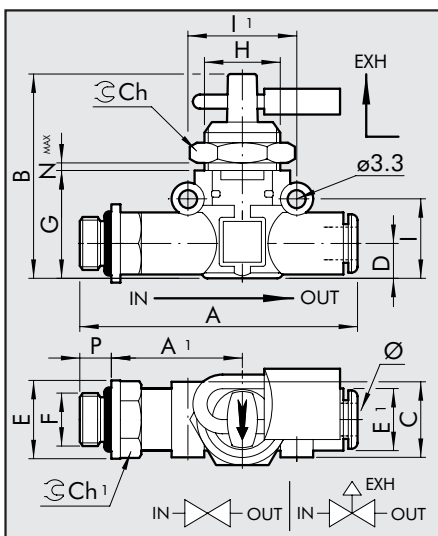

9065508	V2V L 1/8-6 KEY	1/8	6	6	57.3	27.8	41	14.7	6.4	14	11.4	21	M15x1	14.6	20	17	12	5.5
9066508	V3V L 1/8-6 KEY																	
9065509	V2V L 1/4-6 KEY	1/4	6	8	60.3	28.8	41	14.7	6.4	18	11.4	21	M15x1	14.6	20	17	14	5.5
9066509	V3V L 1/4-6 KEY																	
9065510	V2V L 1/8-8 KEY	1/8	8	6	65.3	31.8	46	18.7	9.1	15	13.8	26	M15x1	18.7	24	17	14	5.5
9066510	V3V L 1/8-8 KEY																	
9065511	V2V L 1/4-8 KEY	1/4	8	8	69.7	34.2	46	18.7	9.1	18	13.8	26	M15x1	18.7	24	17	14	5.5
9066511	V3V L 1/4-8 KEY																	
9065512	V2V L 3/8-8 KEY	3/8	8	9	71.3	34.8	46	18.7	9.1	22	13.8	26	M15x1	18.7	24	17	17	5.5
9066512	V3V L 3/8-8 KEY																	

NOTES