

FLOW SWITCH

FS Series - Flow Switch made from Noryl

FS-01

Design Features

- Rugged high grade black Noryl
- Minimal pressure drop
- Operates from a small head of water
- Vertical mount +/- 15°
- Suitable for water and air flow switching



Product Comments

- 3/4 inch BSP male and female threaded fittings
- Suitable for hot and cold portable water
- Reed Switch reliability
- Meets UL 94-HB flammability rating
- Easy installation

Typical Applications

- Flow sensing
- Power Shower
- Central Heating Systems
- Vending Machines
- Cooling systems

Material, Design and Operation

Mounting:	Flow switch Vertical
Material:	Noryl
Fitting	Flow switch 3/4" BSP
Contact Form:	Form A - Triac
Contact Material:	Triac
Maximum Switching Volts:	250 VRMS
Maximum Switching Current:	3.0 A
Cable Type:	0.5mm ² BS6500 PVC double insulated 1.0M long
Cable Colour:	White outer Blue/Brown inner
Operating Temperature Range:	85 °C
Medium/Liquid:	Water
Flow Rate:	1.0 litres/min
Operating Pressure:	10 BAR
Sealing Components:	Silicone
Working Voltage:	12.0 - 15.0VDC
Mounting Shock:	50g for 11ms duration
Mounting Vibration:	35g up to 500Hz
Approvals:	Meets UL 94-HB flammability rating
Mounting:	Flow switch Vertical

Line Drawing

FS-01

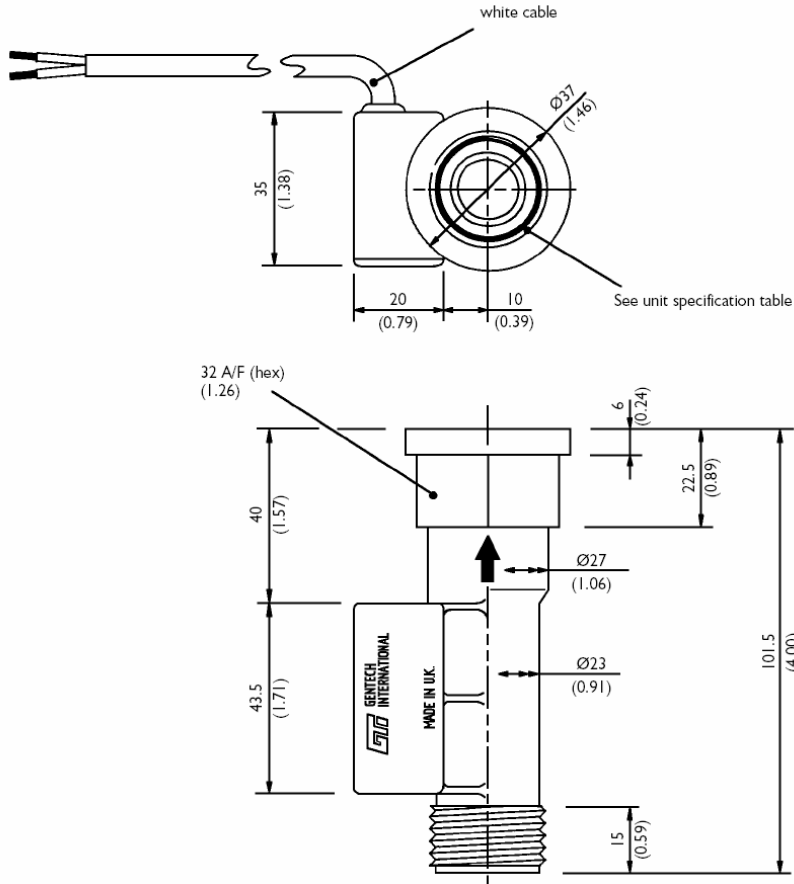

FLOW RATE v PRESSURE DROP

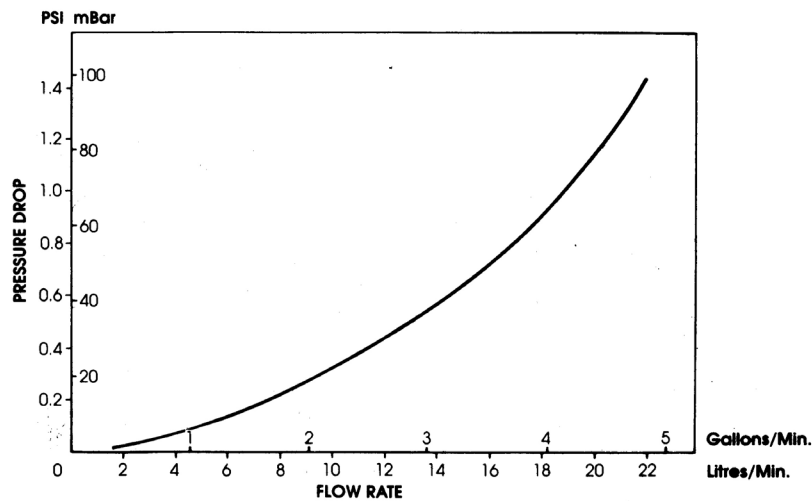

Installation

Care must be taken to ensure that the flow switch is not damaged due to excessive tightening. The torque must not exceed the maximum limit stated. The installation should be checked to ensure that no leaking is evident.

- Mating connectors to have 3/4" BSP
- Pipework/connector alignment imperative (avoiding bending stress).
- Washer and pipe sealant type ANACURE 6124 (or equivalent) recommended.
- Tighten fittings to maximum torque of 20Nm (15lb/ft).