



HCP2 Relay

No.50062453

E164730

CQC05001014504



1.COIL DATA

| | |
|---------------------|--------------------------|
| 1-1.Nominal Voltage | 5,6,12,24,48VDC |
| 1-2.Coil Resistance | Refer to Coil Data Chart |
| 1-3.Operate Voltage | Refer to Coil Data Chart |
| 1-4.Release Voltage | Refer to Coil Data Chart |
| 1-5.Nominal Power | 400mW |

2.CONTACT DATA

| | |
|---------------------------|---|
| 2-1.Contact Form | A-2 Form A ,C-2 Form C |
| 2-2.Contact Material | AgAlloy |
| 2-3.Contact Rating | Resistive: 8A 250VAC/30VDC Inductive: 4A 250VAC Cos φ =0.4 |
| 2-4.Max.Switching Voltage | 380VAC/30VDC |
| 2-5.Max.Switching Current | 8A |
| 2-6.Max.Switching Power | 2000VA,240W |
| 2-7.Min.Switching Load | 5VDC,100mA |
| 2-8.Contact Resistance | Max 100mΩ(6VDC 1A) |
| 2-9. Life | |
| Electrical | 100,000 operations |
| | 50,000operations (Inductive:Cos φ =0.4,L/R=7ms) |
| Mechanical | 20,000,000 operations |

3.GENERAL DATA

| | |
|---------------------------|--|
| 3-1.Insulation Resistance | Min.10000MΩ 500VDC |
| 3-2.Dielectric Strength | 1,000VAC,1min between open contacts 5,000VAC,1min between coil and contacts |
| 3-3.Operate Time | Max.10ms |
| 3-4.Release Time | Max.5ms |
| 3-5.Operate Temperature | -40 ~+85°C |
| 3-6.Shock Resistance | |
| Endurance | 1,000m/s ² |
| Misoperation | 1,00m/s ² |
| 3-7.Vibration Resistance | |
| Endurance | 10 -55Hz,1.5mm double amplitude |
| Misoperation | 10 -55Hz ,1.5mm double amplitude |
| 3-8.Humidity | 35%~95%RH, +40°C |
| 3-9.Weight | Approximately 13.0g |
| 3-10.Safety | UL NO.E164730 TUV NO.50062453 CQC NO.05001014504 |

HCP2 Relay

No.50062453

CULUS
E164730

CQC
CQC05001014504



4.ORDER CODE

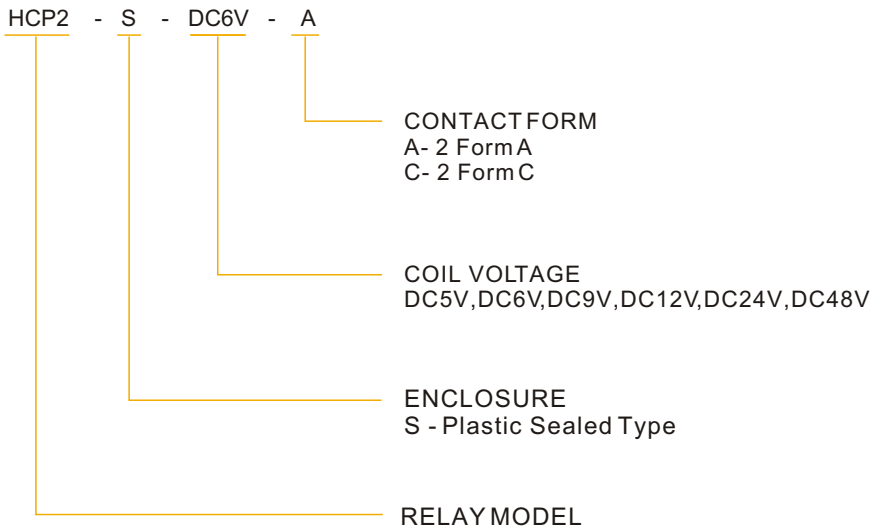

5.COIL DATA CHART

20°C

| Model | Nominal Voltage VDC | Coil Resistance Ω +/-10% | Operate Voltage \leq VDC | Release Voltage \geq VDC | Coil Power mW |
|----------------|---------------------|---------------------------------|----------------------------|----------------------------|---------------|
| HCP2-(S)-DC5V | 5 | 62.5 | 3.5 | 0.5 | 400 |
| HCP2-(S)-DC6V | 6 | 90.0 | 4.2 | 0.6 | |
| HCP2-(S)-DC9V | 9 | 202.5 | 6.3 | 0.9 | |
| HCP2-(S)-DC12V | 12 | 360 | 8.4 | 1.2 | |
| HCP2-(S)-DC24V | 24 | 1440 | 16.8 | 2.4 | |
| HCP2-(S)-DC48V | 48 | 5760 | 33.6 | 4.8 | |

6.DIMENSIONS (mm)

Dimensions

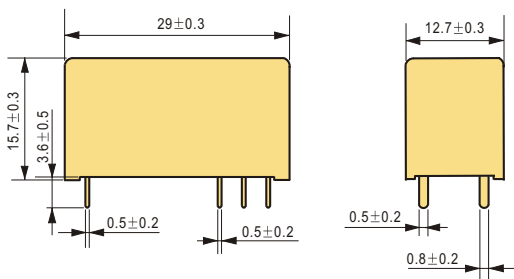

Wiring Diagrams (Bottom View)

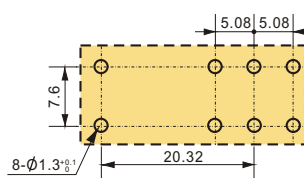

Mounting Hole Layout(Bottom View)

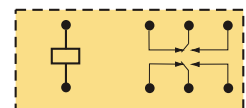

7.HCP2 CHARACTERISTIC CHART DATA

