

### Top View of Assembly

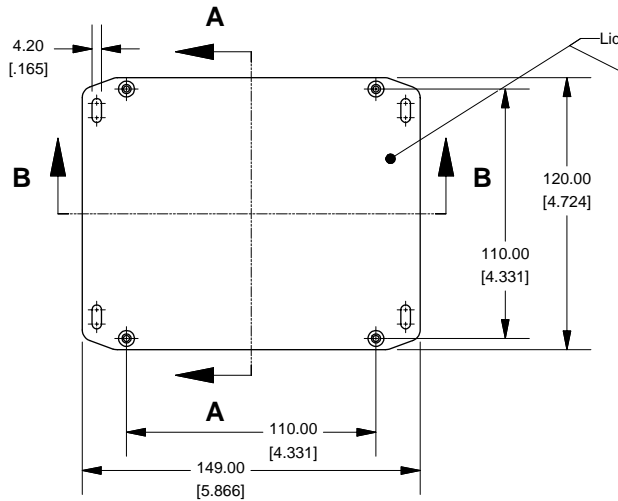

### SECTION A-A End View of Assembly

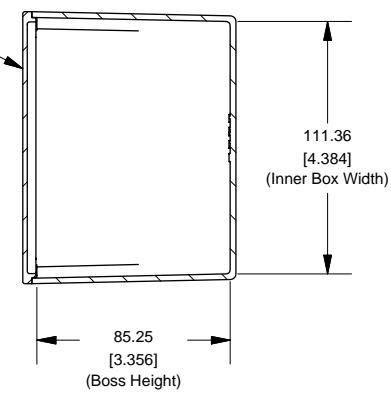

## Series 1590VFL (Flanged Lid)

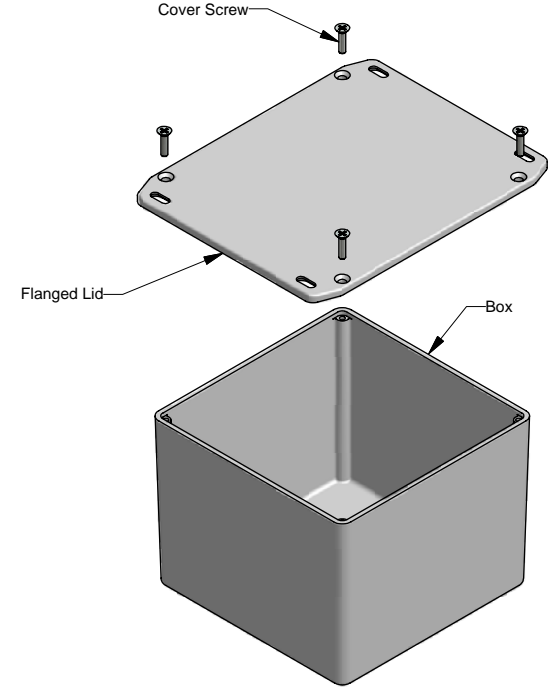

### SECTION B-B Side View of Assembly

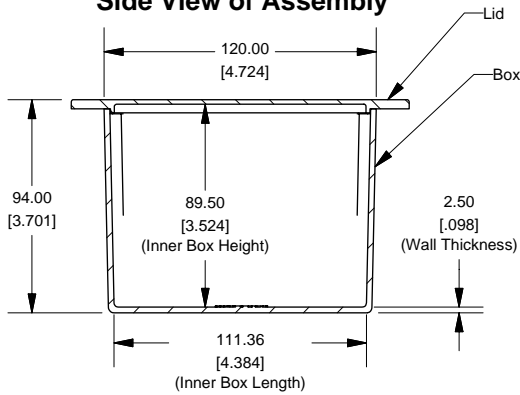

### Top View Looking Inside Box

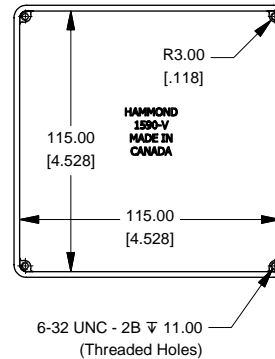

### Lid

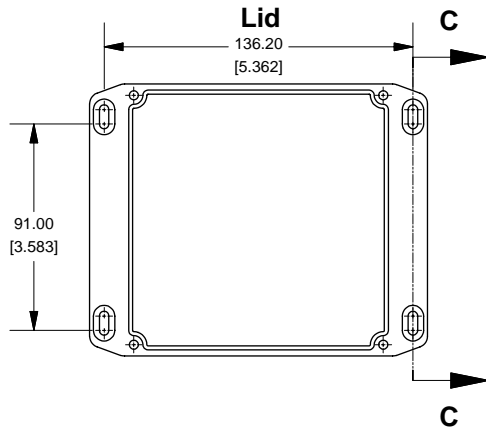

### SECTION C-C Side View of Slot

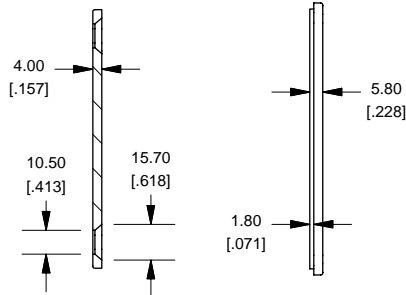

#### NOTE

Purchased assembly includes box, lid and 4 cover screws.  
Box and lid are made from Diecast Aluminum Alloy (alloy type 360.1).

#### PART NUMBERS

1590VFL Enclosure	
Unfinished	1590VFL
Black Textured Powder Paint	1590VFLBK
1590VFL Liquid Resistant Enclosure (Silicon Factory Installed Gasket)	
Unfinished	1590WVFL
Black Textured Powder Paint	1590WVFLBK
ACCESSORIES	
Unfinished	
Cover Screws (Pkg 100) [6-32 x 1/2" Nickel Plated Screws]	1590MS100
Black Textured Powder Paint	
Cover Screws (Pkg 50) [6-32 x 1/2" Stainless Steel Black Screws]	1590MS50BK

