

Top View of Assembly

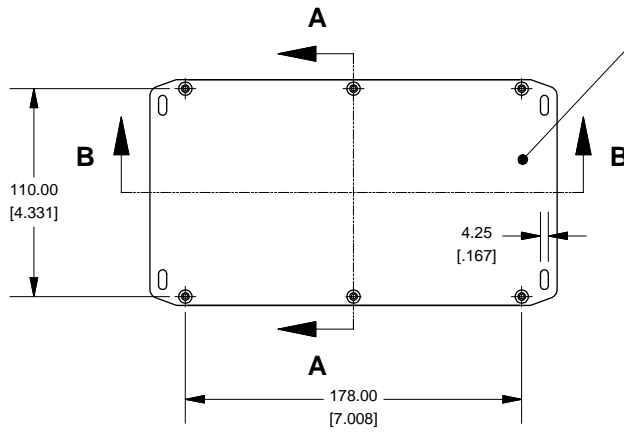

SECTION A-A End View of Assembly

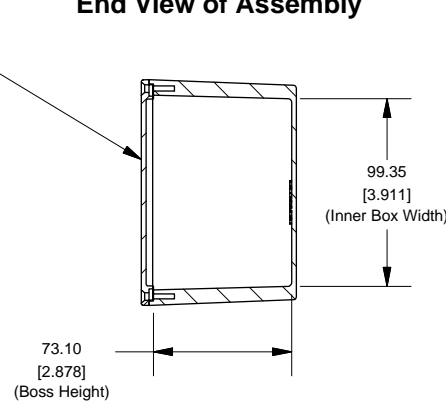

Series 1590EFL (Flanged Lid)

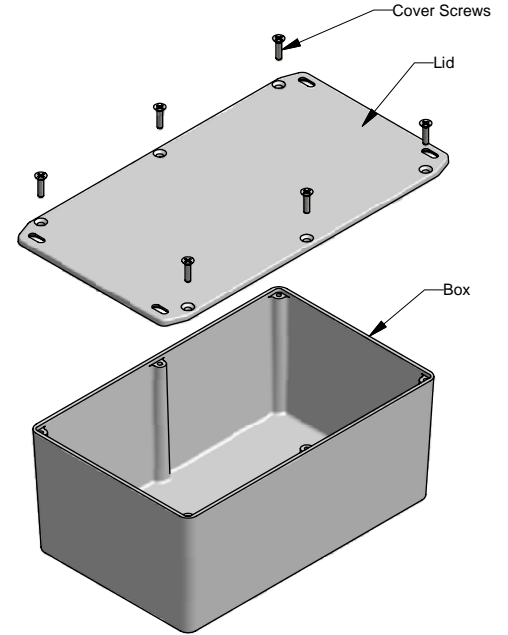

SECTION B-B Side View of Assembly

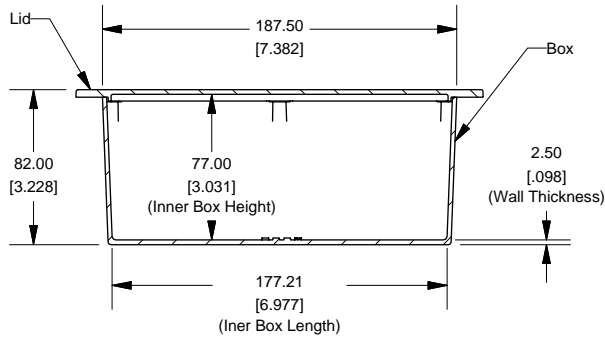

Top View Looking Inside Box

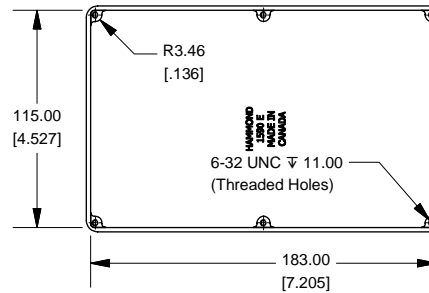

NOTE
Purchased assembly includes box, lid and 4 cover screws.
Box and lid are made from Diecast Aluminum Alloy (alloy type 360.1).

PART NUMBERS	
1590EFL Enclosure	
Unfinished	1590EFL
Black Textured Powder Paint	1590EFLBK
1590EFL Liquid Resistant Enclosure (Silicon Factory Installed Gasket)	
Unfinished	1590WEFL
Black Textured Powder Paint	1590WEFLBK
ACCESSORIES	
Unfinished	
Cover Screws (Pkg 100) [6-32 x 1/2" Nickel Plated Screws]	1590MS100
Black Textured Powder Paint	
Cover Screws (Pkg 50) [6-32 x 1/2" Stainless Steel Black Screws]	1590MS50BK

Lid

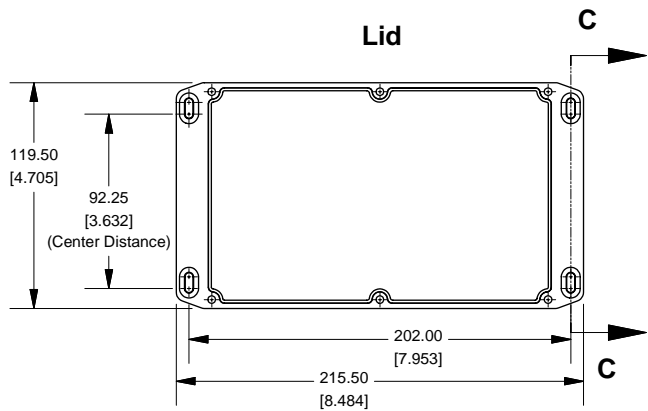

SECTION C-C Side View of Slot

