

Top View of Assembly

SECTION A-A
End View of Assembly

Series 1590DD (Flanged Lid)

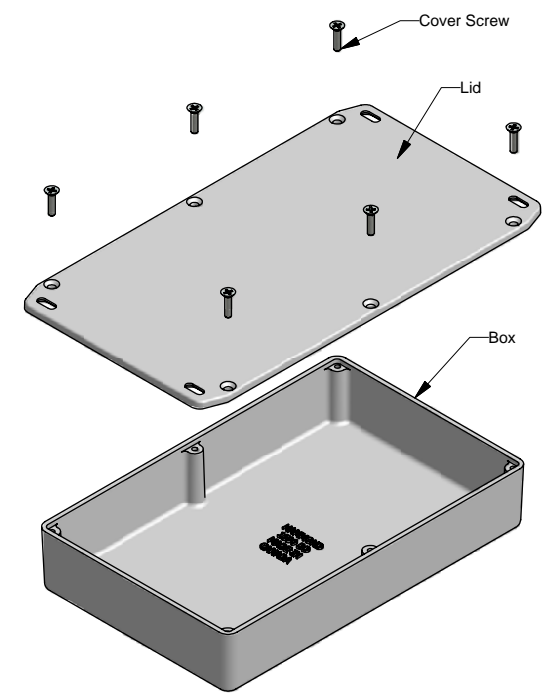
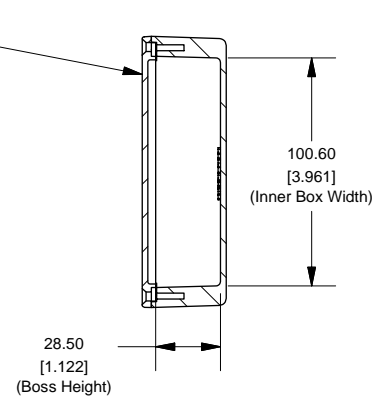
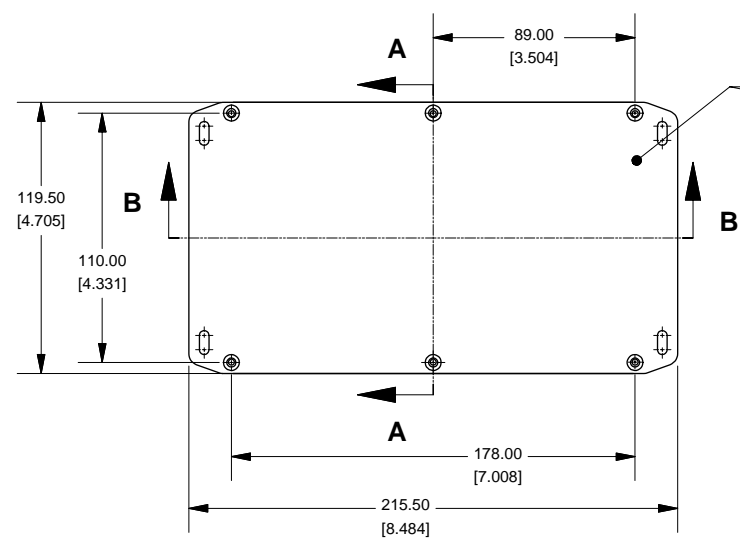

SECTION B-B
Side View of Assembly

Top View Looking Inside Box

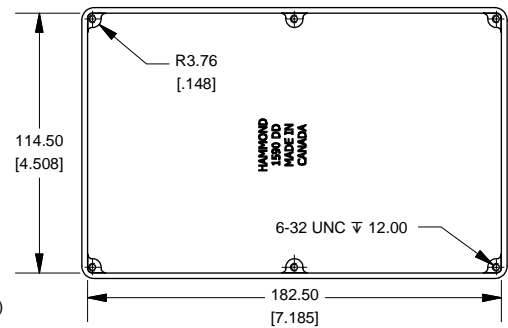
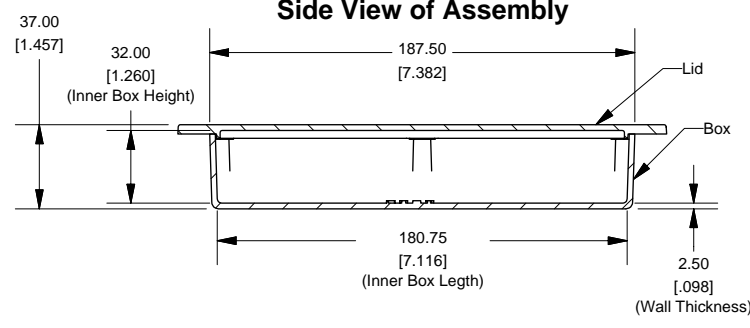

NOTE
 Purchased assembly includes box, lid and 4 cover screws.
 Box and lid are made from Diecast Aluminum Alloy (alloy type 360.1).

PART NUMBERS	
1590DDFL Enclosure	
Unfinished	1590DDFL
Black Textured Powder Paint	1590DDFLBK
1590DDFL Liquid Resistant Enclosure (Silicon Factory Installed Gasket)	
Unfinished	1590WDDFL
Black Textured Powder Paint	1590WDDFLBK
ACCESSORIES	
Unfinished	
Cover Screws (Pkg 100)	1590MS100
[6-32 x 1/2" Nickel Plated Screws]	
Black Textured Powder Paint	
Cover Screws (Pkg 50)	1590MS50BK
[6-32 x 1/2" Stainless Steel Black Screws]	

Lid

SECTION C-C
Side of Slot

