

# Crimp Attachment for Flexible Cable and Direct Solder for Semi-Rigid Cable

## Solder Jack - Semi-Rigid Cable

P.N.	Cable Group	Plt.	Ins.	Imp.	Crimp Tool
N6181A1-N/3GT3G-10-50	10	Nickel/Gold	Teflon	50	N/A
N6181A1-N/3GT3G-11-50	11	Nickel/Gold	Teflon	50	N/A

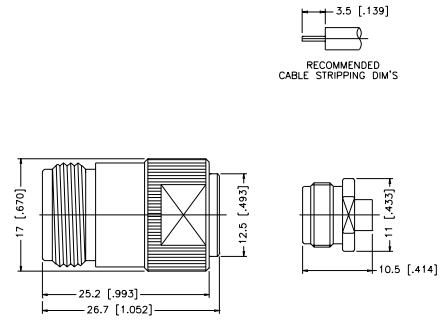

Assembly Instruction G - page 229

## Bulkhead Crimp Jack - Captive Contact - Standard Cable

P.N.	Cable Group	Plt.	Ins.	Imp.	Crimp Tool
N6421A1-NT3G-1-50	01	Nickel	Teflon	50	3 or 4
N6421A1-NT3G-1A-50	01A	Nickel	Teflon	50	4
N6421A1-NT3G-1B-50	01B	Nickel	Teflon	50	4
N6421C1-001-NT3G-2-50	02	Nickel	Teflon	50	4
N6421C1-001-NT3G-3-50	03	Nickel	Teflon	50	4
N6421G1-NT3G-5-50	05	Nickel	Teflon	50	1 or 2
N6311A1-NT3G-5-50	05	Nickel	Teflon	50	1
Front Mount					
N6421G1-001-NT3G-5A-50	05A	Nickel	Teflon	50	2
N6421A1-NT3G-7-50	07	Nickel	Teflon	50	6 + 1
N6421A1-NT3G-7A-50	07A	Nickel	Teflon	50	6 + 1
N6421A1-NT3G-7B-50	07B	Nickel	Teflon	50	4
N6421A2-NT3G-7C-50	07C	Nickel	Teflon	50	6
N6421A4-NT3G-17-50	17	Nickel	Teflon	50	.610 hex
N6421C5-NT3G-LMR500-50	LMR500	Nickel	Teflon	50	.600 hex

Remark: Rear Mount, except where indicated

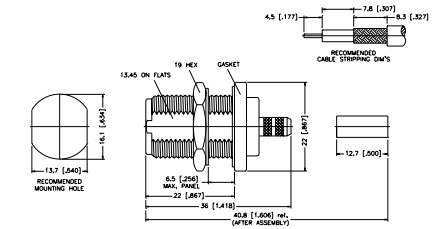

Assembly Instruction J - page 232

## Bulkhead Solder Jack - Semi-Rigid Cable

P.N.	Cable Group	Plt.	Ins.	Imp.	Crimp Tool
N6481A2-001-NT3G-10-50	10	Nickel	Teflon	50	N/A
N6381A1-N/3GT3G-10-50	10	Nickel/Gold	Teflon	50	N/A
Front Mount					
N6481A2-NT3G-11-50	11	Nickel	Teflon	50	N/A
N6381A1-N/3GT3G-11-50	11	Nickel/Gold	Teflon	50	N/A
Front Mount					
N6481A2-NT3G-12-50	12	Nickel	Teflon	50	N/A

Remark: Rear Mount, except where indicated

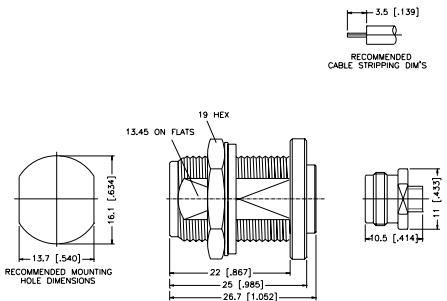

Assembly Instruction G - page 229

## Bulkhead Crimp Jack - Ethernet Cable

P.N.	Cable Group	Plt.	Ins.	Imp.	Crimp Tool
N6421A1-NT3G-9880-50	9880	Nickel	Teflon	50	6
N6421A1-NT3G-89880-50	89880	Nickel	Teflon	50	6

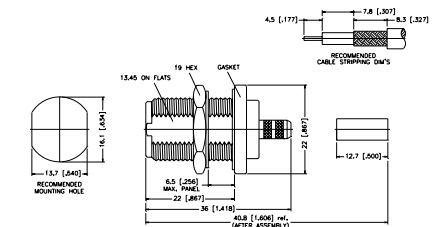

Crimp On  
Assembly Instruction J - page 232

## Cable Assembly Instruction J

## Crimp-crimp

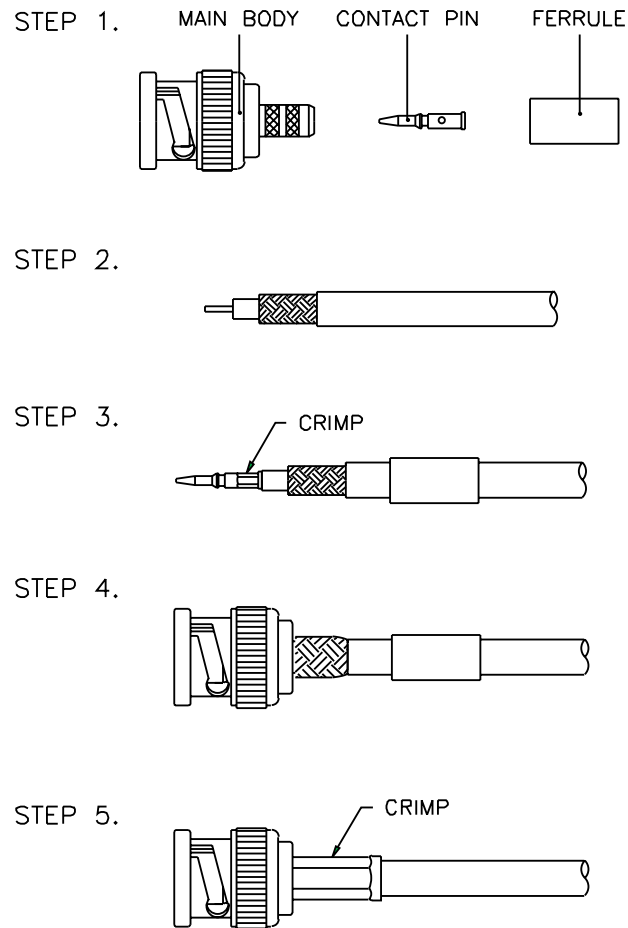

- STEP 1.** All parts of the connector are shown. A crimp tool is necessary to complete the connection.
- STEP 2.** Strip the cable inner conductor, dielectric, braid, and jacket as per "RECOMMENDED CABLE STRIPPING DIM'S" in catalog.
- STEP 3.** Insert inner conductor into the CONTACT PIN and solder on the cable. Then slide the FERRULE onto cable.
- STEP 4.** Insert the MAIN BODY into braid and dielectric.
- STEP 5.** Slide the FERRULE over braid, crimp it with the crimp tool as shown.