

Stewart Connector

MagJack[®] Family of Modular Jacks with Integrated Magnetics

SI Series

**Clean up your signal,
free up your board.**

The Choice is Yours.

Now all of your high-speed networking applications can reap the benefits of MagJack's integrated magnetic design. Stewart offers MagJack connectors in standard, stacked, LED and high temperature versions, in a variety of configurations and with a wide range of options. We've got exactly what you need to make your designs a reality.

Protect Your Signal.

All MagJack modular connectors feature integrated magnetic components housed within the jack body, protecting your signal from internally and externally generated noise that can diminish network performance. They provide improved common-mode filtering over discrete magnetic components and reduce near-field noise coupling.

Say Goodbye to EMI.

Our integrated design moves InNet Technologies filtering components to where they're needed most

– within the jack housing – ensuring the utmost in signal integrity while boosting reliability and performance. MagJack connectors are ideal for new designs where the full benefit of trace reductions and via elimination can be gained through maximum integration.

Save Your Space.

Because MagJack's magnetic components are integrated into the jack itself, you reclaim valuable PCB real estate. Add more components, increase functionality, and add as many bells and whistles as you'd like with MagJack.

Magnetics
by InNet™



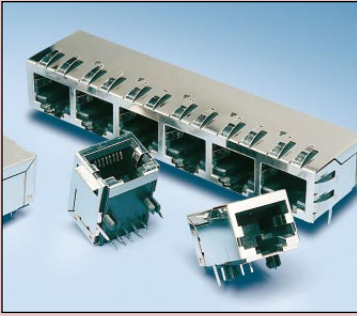

MagJack SI-10000 Series The MagJack

These eight-position jacks deliver reliable, enhanced filtering performance – all within a single connector. Available in single, 4, 6, and 8 port versions with a full range of magnetic options. The MagJack SI 10000 is the ideal solution for high performance networking and telecommunications equipment.

- Full magnetic options including: transformers, chokes, termination resistors, and capacitors available
- Single, four, six, and eight port
- Shielded and unshielded
- Identical form factor as standard jacks
- Gold-plated contacts
- Meets FCC mechanical and dimensional requirements

MagJack® ST SI-10000 Series

Standard Temperature
Eight-Contact, Eight-Position
Single and Multiport
Enhanced Shield
Full Magnetic Options

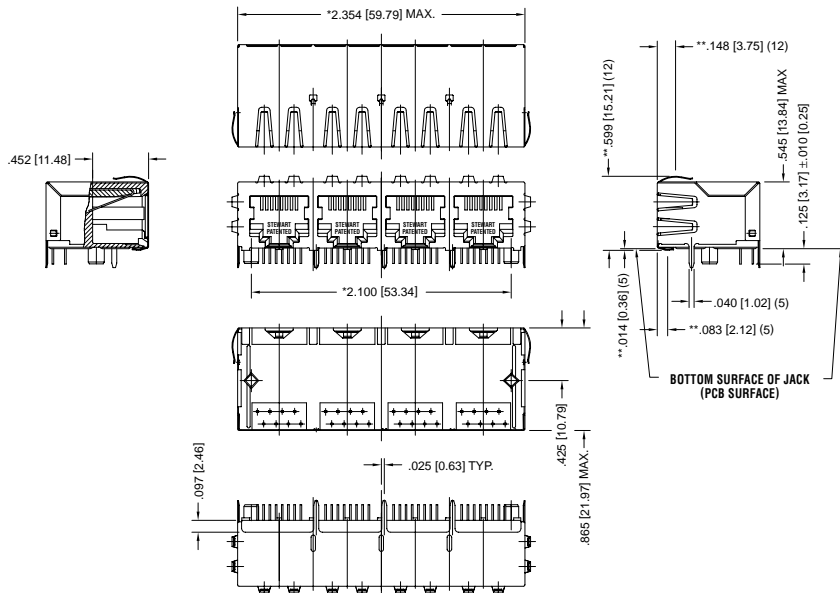

Recommended Panel Cutout

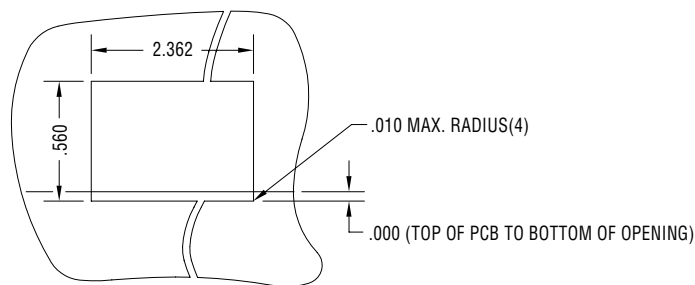

Recommended Board Layout

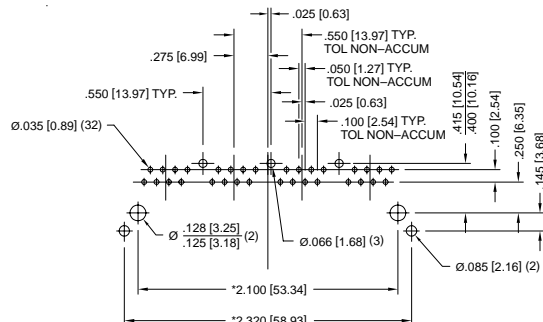

Information subject to change without notice. To obtain drawings and current specifications, contact Stewart Connector Systems, Inc. 11118 Susquehanna Trail South, Glen Rock, PA 17327-9199. Telephone: 717-235-7512. FAX 717-235-7954. <http://www.stewartconnector.com>

Use the
MagJack
Specifier
today!

Take the
guesswork
out of selecting
the perfect
MagJack connector.

www.stewartconnector.com/magjackspecifier

MagJack® ST SI-20000 Series

Standard Temperature
 Six Contact, Six Position
 Eight-Contact, Eight-Position
 Single and Multiport
 Enhanced Shield
 Common Mode Choke



MagJack SI 20000 Series Choke MagJack

For applications that do not require full magnetics, these eight-position jacks deliver many of the same benefits as the MagJack SI 10000 series connectors, but replace the full complement of integrated magnetic components with an economical choke-only configuration.

- Chokes are optimized for problem frequencies
- Single, four, six, and eight port
- Shielded and unshielded
- Identical form factor as standard jacks
- Gold-plated contacts
- Meet FCC mechanical and dimensional requirements

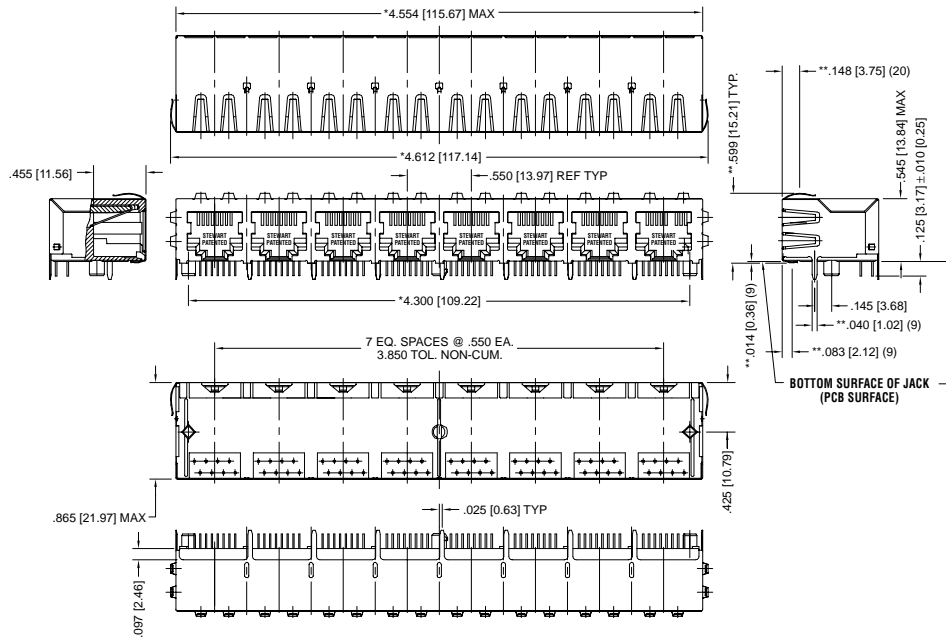

Recommended Panel Cutout

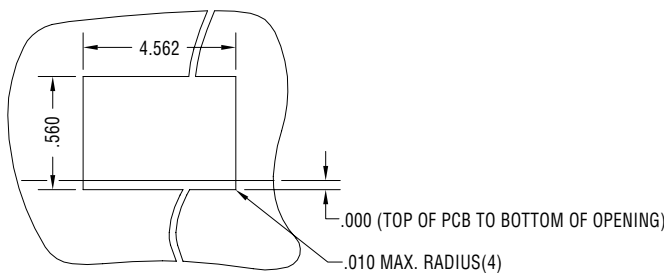

Recommended Board Layout

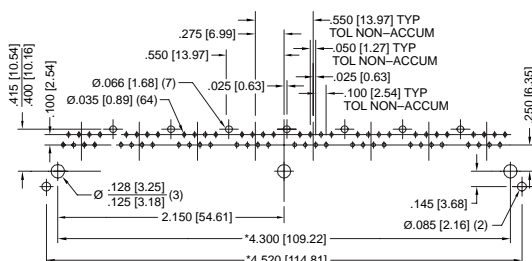

Typical 100BASE-T Common Mode Choke Circuit Drawing

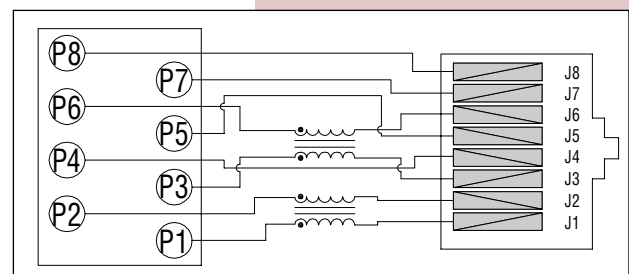

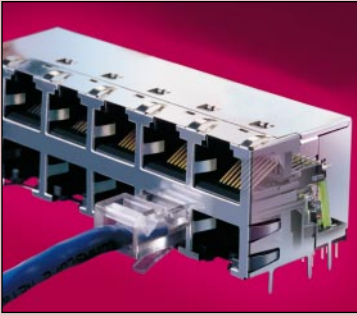

MagJack SI-30000 Series StackMagJack™

Take all of the reliability and performance features of the SI 10000 Series, add another row of ports while lowering the profile, and you've got the SI 30000 Series of multiport connectors that add ports without adding size to your networking devices. The MagJack® SI 30000 connectors are available with up to 16-ports (8/8) and enable you to build compact, cutting edge multiport devices with maximum port densities quickly and easily.

- Full magnetic options including: transformers, chokes, termination resistors, and capacitors available
- Eight (4/4), twelve (6/6), sixteen (8/8) port
- Shielded and unshielded
- Identical form factor as standard jacks
- Gold-plated contacts
- Meet FCC mechanical and dimensional requirements

MagJack® ST SI-30000 Series

Standard Temperature
Eight-Contact, Eight-Position
Stacked Multiport
Enhanced Shield

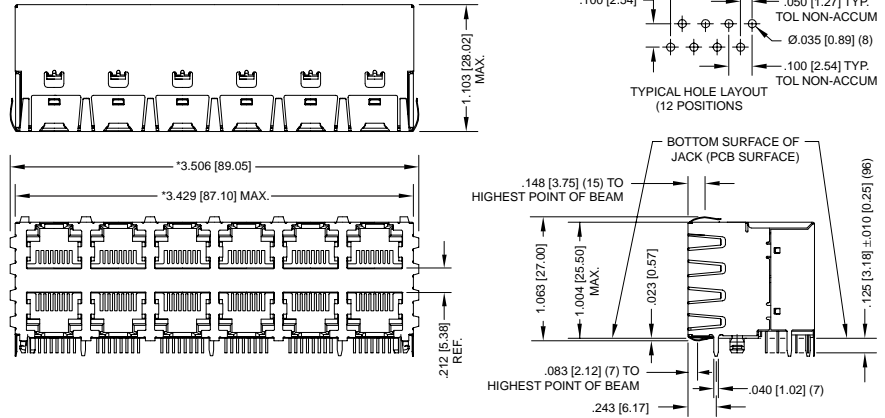

Recommended Panel Cutout

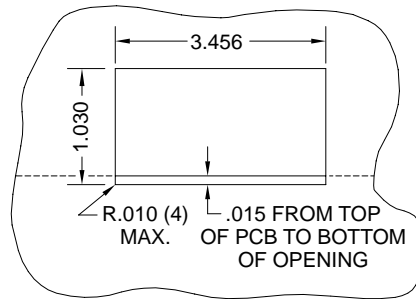

Recommended Board Layout

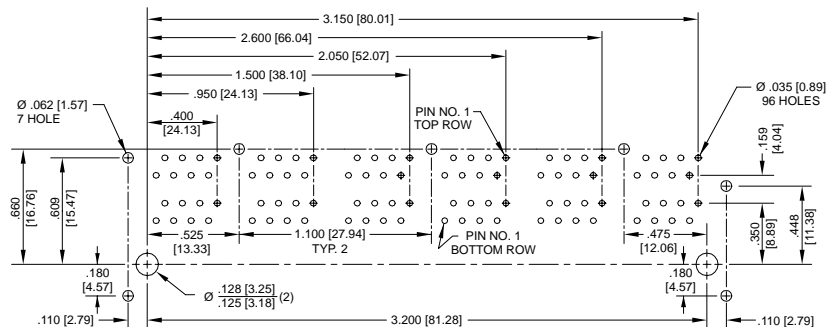

Use the
MagJack
Specifier
today!

Take the
guesswork
out of selecting
the perfect
MagJack connector.

www.stewartconnector.com/magjackspecifier

MagJack® ST SI-40000 Series

Standard Temperature
 Eight-Contact, Eight-Position
 Single and Multiport
 Shielded/Unshielded
 Integrated LEDs

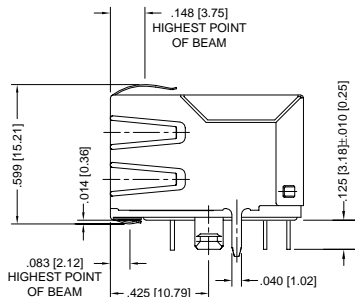
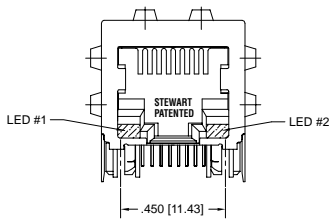
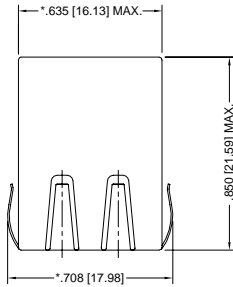

Recommended Panel Cutout

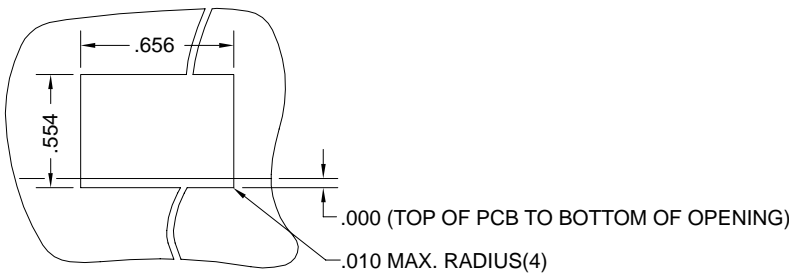

Recommended Board Layout

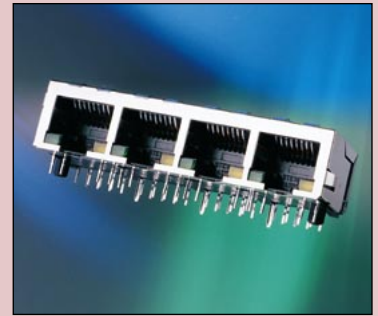
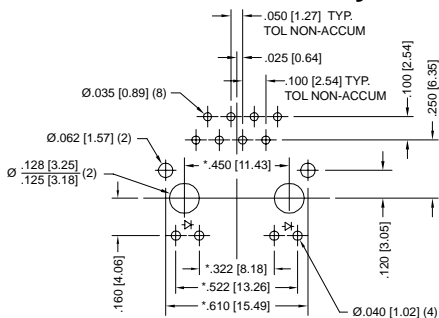

MagJack SI-40000 Series LED MagJack

Available with red, green, or bicolor LEDs, the MagJack SI 40000 connectors are the perfect solution for high performance networking equipment that requires user diagnostic information, such as Hubs, switches, concentrators, bridges and routers, and point-to-point links. And with its long-term dependability, Stewart SI 40000 connectors can help give your network devices a solid edge – lowering warranty costs and increasing customer satisfaction.

- Full magnetics and choke configurations
- One, four, six port
- Single and bi-color LEDs
- Shielded and unshielded
- Identical form factor as standard jacks
- Gold-plated contacts
- Meet FCC mechanical and dimensional requirements

Typical 10/100BASE-T Circuit Drawing

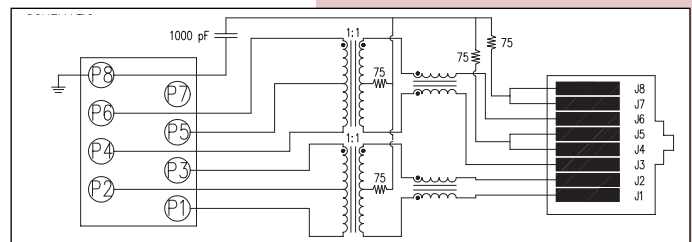



MagJack SI-50000 Series MagJack HT

The new MagJack HT high temperature modular jack is designed to withstand the hostile temperatures associated with PCB manufacturing and features a tab-up design that reduces the effects of EMI/RFI. The MagJack HT connector fits current industry standards for profile and envelope, making them drop-in replacements for existing PCB designs. Optional LED light pipes, mounted outside the jack shielding, provide vivid indication without increasing noise.

- Full magnetic options including: transformers, chokes, termination resistors, and capacitors available
- Reflow compatible
- Tab-up design minimizes EMI/RFI
- Optional integrated light pipes/LED system
- Identical form factor as standard jacks
- Gold-plated contacts
- Meet FCC mechanical and dimensional requirements
- High temperature Liquid Crystal Polymer (LCP) material

MagJack® HT SI-50000 Series

High Temperature
Eight-Contact, Eight-Position
Single Port
Shielded

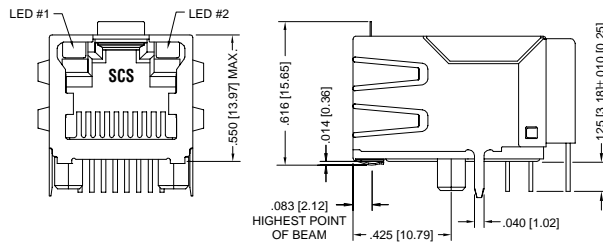
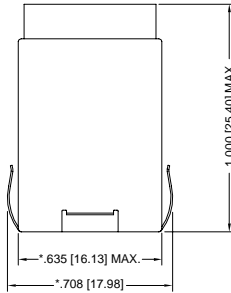

LED POLARITY
(ENLARGED VIEW)

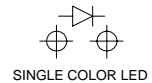

SINGLE COLOR LED

Recommended Panel Cutout

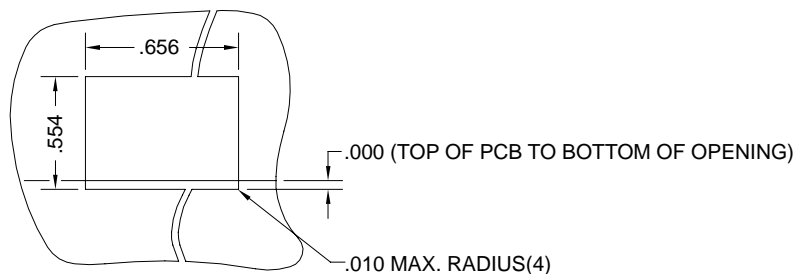

Recommended Board Layout

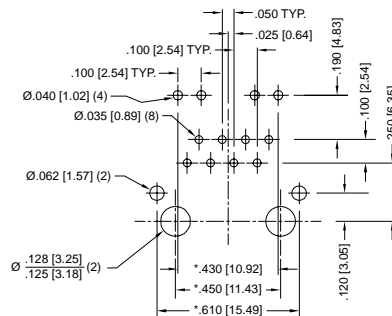

Information subject to change without notice. To obtain drawings and current specifications, contact Stewart Connector Systems, Inc. 11118 Susquehanna Trail South, Glen Rock, PA 17327-9199. Telephone: 717-235-7512. FAX 717-235-7954. <http://www.stewartconnector.com>

Use the
MagJack
Specifier
today!

Take the
guesswork
out of selecting
the perfect
MagJack connector.

www.stewartconnector.com/magjackspecifier

MagJack® XT SI-60000 Series

Extended Temperature
Eight-Contact, Eight-Position
Single Port
Shielded/Unshielded

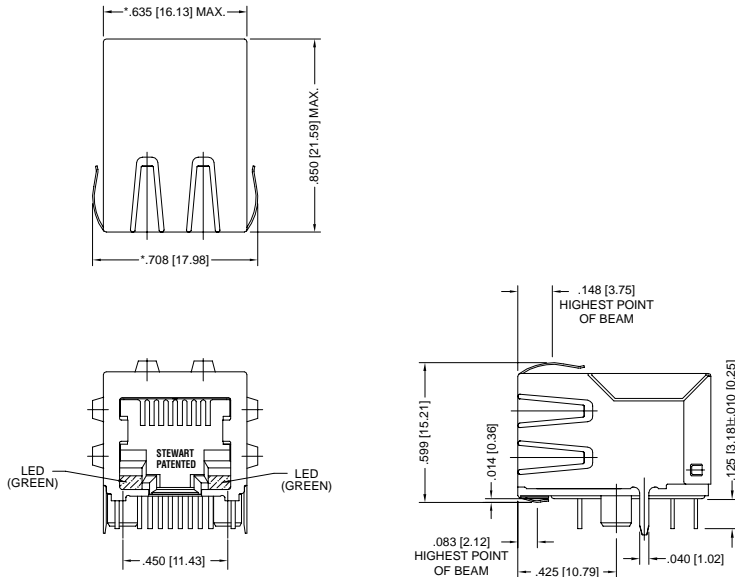

Recommended Panel Cutout

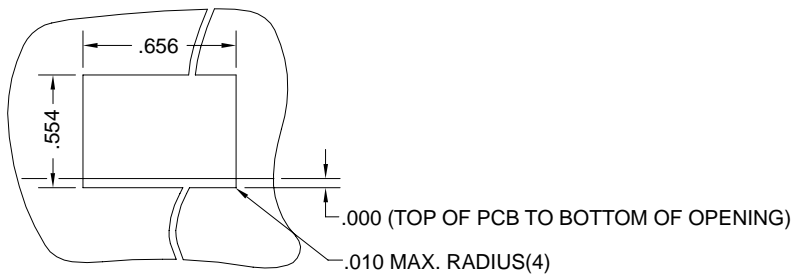

Recommended Board Layout

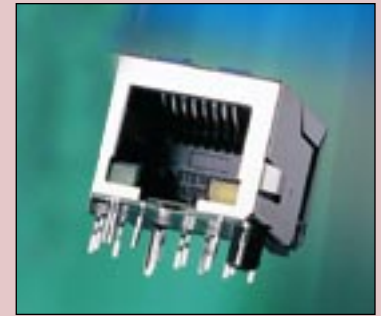
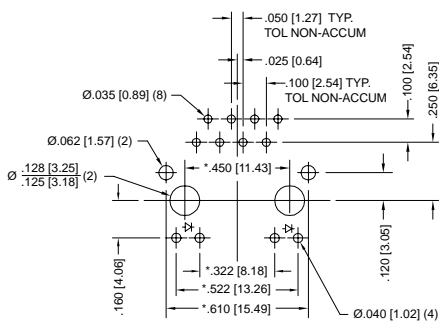

**MagJack SI-60000 Series
MagJack XT**

The new MagJack XT extended temperature single port modular jack is designed specifically for challenging reflow applications and is available with optional integrated single or bicolor LEDs. The MagJack XT fits current industry standards for profile and envelope, making them drop-in replacements for existing PCB designs, and perfect where powerful integrated components are required in a single port configuration.

- Full magnetic options including: transformers, chokes, termination resistors, and capacitors available
- Reflow compatible
- Optional LEDs
- Single port
- Shielded and unshielded
- Identical form factor as standard jacks
- Gold-plated contacts
- Meet FCC mechanical and dimensional requirements

Typical 5-Core Circuit Drawing

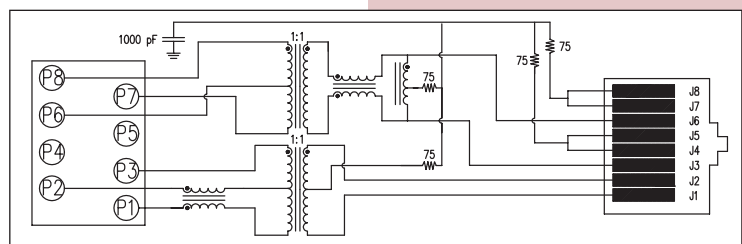

Materials

Housing:	Thermoplastic, UL 94V-0
Contacts:	Copper Alloy
Plating:	Selectively plated gold at 50 microinches over nickel (FCC certifiable) Tin-lead on solder tails
Shield:	Tin-plated brass

Electrical Requirements

Dielectric Withstanding: 1500 VAC *

Insulation Resistance: 500 M Ω (minimum)

Contact Resistance: 15 m Ω (maximum)

Mechanical Requirements

Contact Normal Force: 100 grams (minimum)

Durability: 1000 cycles minimum (using Stewart Connector plug)

Environmental Requirements

High Temperature Life 85° C

Approvals and Certifications

FCC compliant

UL recognition pending

CSA certification pending

* Across both sides of transformers

Stewart Connector Systems, Inc. is ISO 9001 certified.

Ordering Information

When ordering the SI Series MagJack, the 7-digit part number will begin with SI. The remaining 5 digits will be provided by Stewart Connector based on the following criteria:

- MagJack type (StackMagJack, MagJack HT, MagJack XT, etc.)
- Circuit (100Base-T, 10Bast-T, RJ-11, Token Ring, etc.)
- Number of ports
- Shielding options

Consult factory for other available options and configurations.

Stewart Connector is dedicated to providing you with the most accurate and timely customer service. When placing a MagJack order, please be prepared with the following information:

- What type of local area network (LAN) are you using or planning to use?
- What transceiver chips are you using? (manufacturer and part number)
- What type of filtering does your application require?
- What configuration does your application require? (hub, switch, router, etc.)
- How many ports are required per connector?
- Will you need shielding? Does that shielding need to be enhanced in any way?
- Are there other special application requirements? (high temperature, surface mount, integrated LEDs, etc.)

Stewart Connector understands the importance of choosing the connector that's perfect for your needs. That's why we've created an online Web-based application that takes the guesswork out of selecting the connector that matches your specific requirements. The MagJack Specifier, found at www.stewartconnector.com/magjackspecifier, provides detailed information, mechanical and electrical circuit drawings, and ordering information for the complete line of MagJack connector products.

Stewart Connector Systems, Inc. Insilco Technologies Group

11118 Susquehanna Trail South
Glen Rock, PA 17327-9199
Tel: 717-235-7512
Fax: 717-235-7954

Stewart Connector Systems GMBH Insilco Technologies Group

Industriestrasse 20, D-61381
Friedrichsdorf, Germany
Tel: +49-6172-9552-0
Fax: +49-6172-9552-40

Stewart Connector Systems GMBH Insilco Technologies Group

Cumberland House, Baxter Ave.
Southend-On-Sea
Essex SS2 6HZ, UK
Tel: +44-1-702-226000
Fax: +44-1-702-2266010

Stewart Connector Systems (Japan), Inc. Insilco Technologies Group

City Center Bldg. II
3-1-42, Chigasaki-Minami
Tsuzuki-Ku, Yokohama, 224,
Japan
Tel: +81-45-943-5177
Fax: +81-45-943-5178



Insilco Technologies Group

www.insilcotechologies.com

Escod Industries • Signal Transformer • Stewart Connector • Stewart Stamping