

Customer :

No. SW065072A

ALPS EUROPE DISTRIBUTION

Date : 2006- 07- 20

Attention :

Your ref. No. :

Your Part No. : SSSS928200

# SPECIFICATION

ALPS' ;

MODEL : STSSS9233

Spec. No. : SSSS9-S-501

Sample No. : F3291355H

## RECEIPT STATUS

RECEIVED

By Date

Signature

Name

Title

**ALPS**<sup>®</sup>  
ALPS ELECTRIC CO., LTD.

DSG' D K. Tomita

APP' D K. ITO  
ENG. DEPT. DIVISION

Sales

Head Office  
1-7, Yukigaya-otsuka-cho, Ota-ku, Tokyo. 145-8501 Japan  
Phone. +81(3)3726-1211

DOCUMENT No. SSSS9-S-501	TITLE 製品仕様書	PRODUCT SPECIFICATIONS 製品仕様書	PAGE 1/5
BACKGROUND			⑤

1. General 一般事項

1.1 Application 適用範囲 This specification is applied to low current circuit (Secondary circuit) slide switch used for electronic equipment. この仕様書は主として電子機器に用いる低電流回路用(2次側回路用)スライドスイッチに適用する。

1.2 Operating temperature range 使用温度範囲: -40 ~ 85°C

1.3 Storage temperature range 保存温度範囲: -40 ~ 85°C

1.4 Test conditions 試験状態 Unless otherwise specified, the atmospheric conditions for making measurements and tests are as follows. 試験及び測定は特に規定がない限り以下の標準状態のもとで行う。

Ambient temperature 温度: 5~35°C

△ Relative humidity 相対湿度: 45~90% △

Air pressure 気圧: 86~106kPa (860~1060mmHg)

Should any doubt arise in judgement, tests shall be conducted at the following conditions. ただし、判定に疑義を生じた場合は以下の基準状態で行う。

Ambient temperature 温度: 20±2°C

Relative humidity 相対湿度: 60~70% △

Air pressure 気圧: 86~106kPa (860~1060mmHg)

2. Appearance, construction and dimensions 外観、構造、寸法

2.1 Appearance 外観 Switch shall have good finishing, and no rust, crack or plating failures. 各部の仕上げは良好で、機能上有害な錆、傷、割れ、めっき不良及び剝離等があるてはならない。

2.2 Construction and dimensions 構造、寸法 Refer to individual product drawing. 個別製品図による。

3. Rating 定格

△ Maximum rating 最大定格  $\frac{12}{12}$  V DC  $\frac{0.1}{0.5}$  A (Resistive load)(抵抗負荷)

Minimum rating 最小定格  $\frac{1}{1}$  V DC  $\frac{10}{10}$  mA (Resistive load)(抵抗負荷)

4. Electrical specification 電気的性能

Items 項目	Test conditions 試験条件	Criteria 判定基準
4.1 Contact resistance 接触抵抗	Shall be measured at 1 kHz±200 Hz (20 mV MAX, 50 mA MAX) or 1 A, 6 V DC by voltage drop method. 1 kHz±200 Hz、電圧 20 mV 以下、電流 50 mA 以下による方法。 または DC 5V, 1A の電圧降下法で測定する。	30 mΩ MAX
4.2 Insulation resistance 絶縁抵抗	Test voltage: 500 V DC, measured after 1 min ± 5 s Applied position: Between all terminals Between terminals and ground(frame) DC 500 V の電圧を 1分±5秒間端子相互間、端子フレーム間に印加し、測定する。	100 MΩ MIN
4.3 Voltage proof 耐電圧	Test voltage: 500 V AC (50~60Hz, cut-off current 2 mA) Duration: 1 min Applied position: Between all terminals Between terminals and ground(frame) AC 500 V (50~60Hz、感度電流 2 mA) の電圧を 1分間端子相互間、端子フレーム間に印加する。	No dielectric breakdown shall occur. 絶縁破壊のないこと。
4.4 Changeover timing 切換タイミング		Refer to individual product drawing. 個別製品図による。

5. Mechanical specification 機械的性能

Items 項目	Test conditions 試験条件	Criteria 判定基準
5.1 Operating force 作動力	A static load shall be applied to the root of actuator in operating direction. 操作部の根元に作動方向へ静荷重を加えて測定する。 	Refer to individual product drawing. 個別製品図による。
5.2 Robustness of terminal 端子強度	A static load of $\frac{3}{3}$ N ( $\frac{300}{300}$ mN) shall be applied to the tip of terminal in a desired direction for 1 min. The test shall be done once per terminal. 端子先端の一方へ $\frac{3}{3}$ N ( $\frac{300}{300}$ mN) の静荷重を1分間加える。 ただし、回数は1端子当たり1回とする。	Shall be free from terminal looseness, damage and breakage of terminal holding portion. Terminals may be bent after test. Electrical performance requirement specified in item 4 shall be satisfied. 端子の脱落、破損及び端子保持部の破損のないこと。ただし、端子の曲がりは歪み支えないものとする。また、試験後 4項の電気的性能を満足すること。

3/5	△ 1	特許先発表	June 13, 2003	F.Y	F.Y	S.C.	APPD.	CHKD.	DSGD.
1/5	△ 5	改良先発表	Sep. 25, 01	H.O	J.M	H.K.	Oct. 07, '97	Oct. 7, '97	Oct. 7, '97
3/5	△ 1	特許先発表	June 8, '93	H.K	S.T	H.K.	2006	2006	Kamada

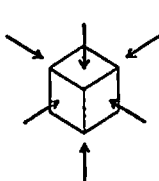
DOCUMENT No. SSSS9-S-501		TITLE PRODUCT SPECIFICATIONS		PAGE 2/5
Items 項目	Test conditions 試験条件	Criteria 判定基準		
5.3 Robustness of actuator 操作部強度	<p>A static load of <math>30\text{ N}</math> (<math>\triangleleft</math> <math>3.0\text{kgf}</math>) shall be applied in the operating direction at the root of actuator for 15 s. <math>\triangleleft</math> 操作部の根元部に作動方向に <math>30\text{ N}</math> (<math>\triangleleft</math> <math>3.0\text{kgf}</math>) の静荷重を15秒間加える。</p> <p>A static load of <math>10\text{ N}</math> (<math>\triangleleft</math> <math>1.0\text{kgf}</math>) shall be applied in the pull direction of actuator for 15 s. <math>\triangleleft</math> 操作部の引張方向に <math>10\text{ N}</math> (<math>\triangleleft</math> <math>1.0\text{kgf}</math>) の静荷重を15秒間加える。</p> <p>Vertical knob type (つまみ上出しタイプ) A static load of <math>10\text{ N}</math> (<math>\triangleleft</math> <math>1.0\text{kgf}</math>) shall be applied in the perpendicular direction of operation at the tip of actuator for 15 s. <math>\triangleleft</math> 操作部の先端に作動方向と直角に <math>10\text{ N}</math> (<math>\triangleleft</math> <math>1.0\text{kgf}</math>) の静荷重を15秒間加える。</p> <p>Horizontal knob type (つまみ横出しタイプ) A static load of <math>5\text{ N}</math> (<math>\triangleleft</math> <math>0.5\text{kgf}</math>) shall be applied in the perpendicular direction of operation at the tip of actuator for 15 s. <math>\triangleleft</math> 操作部の先端に作動方向と直角に <math>5\text{ N}</math> (<math>\triangleleft</math> <math>0.5\text{kgf}</math>) の静荷重を15秒間加える。</p>	<p>Shall be free from pronounced wobble, deformation and mechanical abnormalities. 著しいガタ及び曲がりのないこと。また、機械的に異常のないこと。</p>		
5.4 Wobble of actuator 操作部の揺れ	<p>Run-out(P-P) shall be measured by applying a static load of <math>1\text{ N}</math> (<math>\triangleleft</math> <math>100\text{gf}</math>) in the perpendicular direction of operation at the tip of actuator. <math>\triangleleft</math> 操作部の先端に作動方向と直角に <math>1\text{ N}</math> (<math>\triangleleft</math> <math>100\text{gf}</math>) の静荷重を加え、揺れ幅(最大値)を測定する。</p>	<p>Length of knob つまみ長さ ~ 5 mm ..... 1 mm MAX(P-P) ~ 8 mm ..... 2.5 mm MAX(P-P)</p>		
5.5 Vibration 耐振性	<p>Switch shall be secured to a testing machine by a normal mounting device and method. Switch shall be measured after following test. スイッチを正規の取付用具、取付方法で試験機に固定し、下記条件で試験を行い、試験後測定する。</p> <p>(1)Vibration frequency range 振動数範囲: 10~55 Hz (2)Total amplitude 全振幅: 1.5 mm (3)Sweep ratio 掃引の割合: 10-55-10 Hz Approx. 1 min 約1分 (4)Method of changing the sweep vibration frequency: Logarithmic or linear 掃引振動数の変化方法 対数又は直線近似 (5)Direction of vibration: Three perpendicular directions including actuator 振動の方向 操作部を含む垂直3方向 (6)Duration 振動時間: 2 h each (6 h in total) 各2時間(計6時間)</p>	<p>Contact resistance 接触抵抗 (Item 4.1): <math>30\text{ m}\Omega</math> MAX Insulation resistance 絶縁抵抗 (Item 4.2): <math>100\text{ M}\Omega</math> MIN Voltage proof 耐電圧 (Item 4.3): Apply <math>500\text{ V AC}</math> for 1 min. No dielectric breakdown shall occur. 絶縁破壊のないこと。 Operating force 作動力 (Item 5.1): Within specified value. 規格値内とする。 Shall be free from mechanical abnormalities. 機械的に異常がないこと。</p>		
5.6 Shock 耐衝撃性	<p>Switch shall be measured after following test. 下記条件で試験を行い、試験後測定する。</p> <p>(1)Mounting method 取付方法: Normal mounting method 正規の方法で取り付ける。 (2)Acceleration 加速度: <math>490\text{ m/s}^2</math> (<math>\triangleleft</math> <math>50\text{g}</math>) (3)Duration 作用時間: 11 ms (4)Test direction 試験方向: 6 directions 6面 (5)Number of shocks 試験回数: 3 times per direction (18 times in total) 各方向各3回(計18回)</p> 	<p>Contact resistance 接触抵抗 (Item 4.1): <math>30\text{ m}\Omega</math> MAX Insulation resistance 絶縁抵抗 (Item 4.2): <math>100\text{ M}\Omega</math> MIN Voltage proof 耐電圧 (Item 4.3): Apply <math>500\text{ V AC}</math> for 1 min. No dielectric breakdown shall occur. 絶縁破壊のないこと。 Operating force 作動力 (Item 5.1): Within specified value. 規格値内とする。 Shall be free from mechanical abnormalities. 機械的に異常がないこと。</p>		
5.7 Solderability はんだ付け性	<p>Switch shall be checked after following test. 下記条件で試験を行い、試験後確認する。</p> <p>(1)Solder はんだ: H63A (JIS Z 3282) (2)Flux フラックス: Rosin flux (JIS K 5902) having a nominal composition of 25% solids by mass of water white rosin in 2-propanol (JIS K 8839) solution. ロジン (JIS K 5902) の2-プロパノール (JIS K 8839) 溶液とし、濃度は質量比ロジン約25%とする。 (3)Soldering temperature はんだ温度: <math>230 \pm 5\text{ }^\circ\text{C}</math> Immersing time 浸漬時間: <math>3 \pm 0.5\text{ s}</math> Flux immersing time shall be 5~10 s in normal room temperature. ただし、フラックス浸漬は常温で5~10秒とする。 (4)Immersion depth: Immersion depth shall be at copper plating portion for 浸漬深さ P.C.B. terminal after mounting. Thickness of P.C.B.: 1.6 mm Immersion depth shall be at wiring portion of lead wire for lead wire terminal. プリント基板用端子はプリント基板 (tl.6) 実装後、銅箔面まで浸漬。リード配線用端子は端子のリード線からげ部を浸漬。</p>	<p><math>\triangleleft</math> More than 85 % of immersed part shall be covered with solder. If frame is made of tin-plate, cutting section shall not be applied. 浸漬した部分の 85 % 以上がはんだで覆われていること。 ただし、よりき種の場合は、破断面は適用しない。</p>		

DOCUMENT No.  
SSSS9-S-501

TITLE  
PRODUCT SPECIFICATIONS  
製品仕様書

PAGE  
3/5

Items 項目	Test conditions 試験条件	Criteria 判定基準										
5.8 Resistance to soldering heat はんだ耐熱性	<p>Switch shall be measured after following test. 下記条件で試験を行い、試験後確認する。</p> <p>(1) Solder はんだ: H63A(JIS Z 3282), RH60(JIS Z 3283)</p> <p>(2) Flux フラックス: Rosin flux (JIS K 5902) having a nominal composition of 25% solids by mass of water white rosin in 2-propanol (JIS K 8839) solution.</p> <p>(3) Temperature and immersing time 温度と浸漬時間</p> <table border="1"> <thead> <tr> <th>Temperature 温度(°C)</th> <th>Time 時間(s)</th> </tr> </thead> <tbody> <tr> <td>260 ± 5</td> <td>5<sup>°</sup><sub>-1</sub> (Twice) (2回)*</td> </tr> <tr> <td>260 ± 5</td> <td>10<sup>°</sup></td> </tr> <tr> <td>300 ± 10</td> <td>5 MAX</td> </tr> <tr> <td>△ 350 ± 10</td> <td>3 MAX</td> </tr> </tbody> </table> <p>* Second soldering shall be conducted after the switch cooled down. 1回目終了後、一旦常温に戻すことを条件とする。 Above values shall be applied to the P.C.Board 0.8, 1.0, 1.2 and 1.6 mm thick. (In case of using single sided copper clad phenolic resin P.C.B.) 上記表中の数値はプリント基板 t0.8, t1.0, t1.2, t1.6mm について適用する。 (片面銅張りフェノール樹脂積層板、両面スルーホールガラスエポキシ樹脂積層板を使用した場合) △ Pre-heating condition of dip soldering ティップはんだのプリント条件 - Temperature at the upside surface of P.C.B プリント基板上面温度: 120°C MAX - Time 時間: 60 s</p> <p>(4) Immersion depth 浸漬深さ: Immersion depth shall be at copper plating portion fo P.C.B. terminal after mounting. Thickness of P.C.B. (Single sided copper clad phenolic resin P.C.B.): 1.6 mm プリント基板用端子はプリント基板(片面銅張りフェノール樹脂積層板、両面スルーホールエポキシ樹脂積層板 (t1.6)実装後、銅箔面まで浸漬。</p>	Temperature 温度(°C)	Time 時間(s)	260 ± 5	5 <sup>°</sup> <sub>-1</sub> (Twice) (2回)*	260 ± 5	10 <sup>°</sup>	300 ± 10	5 MAX	△ 350 ± 10	3 MAX	<p>No abnormalities shall be observed in appearance and operation. The electrical performance requirements specified in item 4 shall be satisfied. 外観に著しい変形のないこと。 また、動作に異常がなく、4項の電気的性能を満足すること。 No incursion of flux into the inside of the switch shall occur. スイッチ内部にフラックスが流入しないこと。</p>
Temperature 温度(°C)	Time 時間(s)											
260 ± 5	5 <sup>°</sup> <sub>-1</sub> (Twice) (2回)*											
260 ± 5	10 <sup>°</sup>											
300 ± 10	5 MAX											
△ 350 ± 10	3 MAX											

Items 項目	Test conditions 試験条件	Criteria 判定基準						
6.1 Operating life without load 無負荷寿命	<p>Switch shall be operated 10,000 cycles at 15~20 cycles/min without load. 無負荷にて10,000サイクル(動作速度15~20サイクル/分)連続動作を行う。</p>	<p>Contact resistance 接触抵抗 (Item 4.1): 60 mΩ MAX Insulation resistance 絶縁抵抗 (Item 4.2): 10 MΩ MIN Voltage proof 耐電圧 (Item 4.3): Apply 250 V AC for 1 min. No dielectric breakdown shall occur. 絶縁破壊のないこと。 Operating force 作動力 (Item 5.1): Within ±18% of specified value. 規格値の ±18% 以内。 No abnormalities shall be recognized in appearance and construction. 外観、構造に異常がないこと。</p>						
6.2 Operating life with load 負荷寿命	<p>Switch shall be operated at 15~20 cycles/min with following table. 下記表にて(動作速度15~20サイクル/分)連続動作を行う。</p> <table border="1"> <thead> <tr> <th>Load 負荷</th> <th>Cycles</th> </tr> </thead> <tbody> <tr> <td>△ 12 V DC, 0.1 A (Resistive load 抵抗負荷)</td> <td>10,000</td> </tr> <tr> <td>12 V DC, 0.5 A (Resistive load 抵抗負荷)</td> <td>10,000</td> </tr> </tbody> </table>	Load 負荷	Cycles	△ 12 V DC, 0.1 A (Resistive load 抵抗負荷)	10,000	12 V DC, 0.5 A (Resistive load 抵抗負荷)	10,000	<p>Contact resistance 接触抵抗 (Item 4.1): 60 mΩ MAX Insulation resistance 絶縁抵抗 (Item 4.2): 10 MΩ MIN Voltage proof 耐電圧 (Item 4.3): Apply 250 V AC for 1 min. No dielectric breakdown shall occur. 絶縁破壊のないこと。 Operating force 作動力 (Item 5.1): Within ±18% of specified value. 規格値の ±18% 以内。 No abnormalities shall be recognized in appearance and construction. 外観、構造に異常がないこと。</p>
Load 負荷	Cycles							
△ 12 V DC, 0.1 A (Resistive load 抵抗負荷)	10,000							
12 V DC, 0.5 A (Resistive load 抵抗負荷)	10,000							

Items 項目	Test conditions 試験条件	Criteria 判定基準
7.1 Cold resistance 耐寒性	<p>After testing at -40±2°C for 500 h, the switch shall be allowed to stand under normal room temperature and humidity conditions for 1 h, and then measurement shall be made within 1 h. Water drops shall be removed. -40±2°Cにて500時間試験後、常温常湿中に1時間放置し1時間以内に測定する。 ただし、水滴は取り除く。</p>	<p>Contact resistance 接触抵抗 (Item 4.1): 60 mΩ MAX Insulation resistance 絶縁抵抗 (Item 4.2): 10 MΩ MIN Voltage proof 耐電圧 (Item 4.3): Apply 250 V AC for 1 min. No dielectric breakdown shall occur. 絶縁破壊のないこと。 Operating force 作動力 (Item 5.1): Within ±18% of specified value. 規格値の ±18% 以内。 No abnormalities shall be recognized in appearance and construction. 外観、構造に異常がないこと。</p>

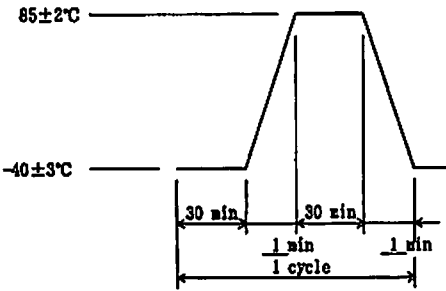
DOCUMENT No. SSSS9-S-501		TITLE 製品仕様書	PRODUCT SPECIFICATIONS 製品仕様書	PAGE 4/5
Items 項目	Test conditions 試験条件	Criteria 判定基準		
7.2 Dry heat 耐熱性	After testing at $85 \pm 2^\circ\text{C}$ for 500 h, the switch shall be allowed to stand under normal room temperature and humidity conditions for 1 h, and then measurement shall be made within 1 h. $85 \pm 2^\circ\text{C}$ にて500時間試験後、常温常湿中に1時間放置し1時間以内に測定する。	Contact resistance 接触抵抗 (Item 4.1): <u>60</u> $\Omega$ MAX Insulation resistance 絶縁抵抗 (Item 4.2): <u>10</u> $\text{M}\Omega$ MIN Voltage proof 耐電圧 (Item 4.3): Apply <u>250</u> V AC for 1 min. No dielectric breakdown shall occur. 絶縁破壊のないこと。 Operating force 作動力 (Item 5.1): Within <u>±15</u> % of specified value. 規格値の <u>±15</u> % 以内。 No abnormalities shall be recognized in appearance and construction. 外観、構造に異常がないこと。		
7.3 Damp heat 耐湿性	After testing at $60 \pm 2^\circ\text{C}$ and 90~95%RH for 500 h, the switch shall be allowed to stand under normal room temperature and humidity conditions for 1 h, and then measurement shall be made within 1 h. Water drops shall be removed. $60 \pm 2^\circ\text{C}$ 、相対湿度90~95%にて500時間試験後、常温常湿中に1時間放置し1時間以内に測定する。ただし、水滴は取り除く。	Contact resistance 接触抵抗 (Item 4.1): <u>60</u> $\Omega$ MAX Insulation resistance 絶縁抵抗 (Item 4.2): <u>10</u> $\text{M}\Omega$ MIN Voltage proof 耐電圧 (Item 4.3): Apply <u>250</u> V AC for 1 min. No dielectric breakdown shall occur. 絶縁破壊のないこと。 Operating force 作動力 (Item 5.1): Within <u>±15</u> % of specified value. 規格値の <u>±15</u> % 以内。 No abnormalities shall be recognized in appearance and construction. 外観、構造に異常がないこと。		
7.4 Salt mist 塩水噴霧	Switch shall be checked after following test. 下記条件で試験を行い、試験後確認する。 (1) Temperature 温度: $35 \pm 2^\circ\text{C}$ (2) Salt solution 塩水濃度: $5 \pm 1\%$ (Solids by mass) (質量比) (3) Duration 試験時間: $24 \pm 1$ h After the test, salt deposit shall be removed in running water. 試験後試料に付着した塩堆積物を流水で落とす。	No remarkable corrosion shall be recognized in metal part. 機能上有害な著しいきびがないこと。		
7.5 Change of temperature 温度サイクル	After 25 cycles of following conditions, the switch shall be allowed to stand under normal room temperature and humidity conditions for 1 h, and measurement shall be made within 1 h after that. Water drops shall be removed. 下記条件で25サイクル試験後、常温常湿中に1時間放置し1時間以内に測定する。ただし、水滴は取り除く。 	Contact resistance 接触抵抗 (Item 4.1): <u>60</u> $\Omega$ MAX Insulation resistance 絶縁抵抗 (Item 4.2): <u>10</u> $\text{M}\Omega$ MIN Voltage proof 耐電圧 (Item 4.3): Apply <u>250</u> V AC for 1 min. No dielectric breakdown shall occur. 絶縁破壊のないこと。 Operating force 作動力 (Item 5.1): Within <u>±15</u> % of specified value. 規格値の <u>±15</u> % 以内。 No abnormalities shall be recognized in appearance and construction. 外観、構造に異常がないこと。		
7.6 Damp heat with load (Resistance to silver migration) 耐湿負荷 (耐銀マイグレーション特性)	DC voltage 1.5 times as much as rated voltage shall be applied continuously between adjacent terminals at $60 \pm 2^\circ\text{C}$ and 90~95%RH. After 500 h testing, switch shall be allowed to stand under normal room temperature and humidity conditions for 1 h, and measurement shall be made within 1 h after that. Water drops shall be removed. $60 \pm 2^\circ\text{C}$ 、相対湿度90~95%にて隣接端子間に定格電圧の1.5倍の直流電圧を連続印加し、500時間試験後、常温常湿中に1時間放置し1時間以内に測定する。ただし、水滴は取り除く。	Insulation resistance 絶縁抵抗 (50V DC): <u>10</u> $\text{M}\Omega$ MIN Voltage proof 耐電圧: Apply 100V AC for 1 min. No dielectric breakdown shall occur. AC 100V、1分間印加。 絶縁破壊のないこと。		

△ シュウドウシンの接点圧力は、0.35N以上とする。

Precaution in use ご使用上の注意

- Note that if the load is applied to the terminals during soldering they might suffer deformation and defects in electrical performance.  
端子をはんだ付けされる場合、端子に荷理が加わりますと条件によりガタ、変形及び電気的特性劣化のおそれがありますのでご注意ください。
- Use of water-soluble soldering flux shall be avoided because it may cause corrosion of the switch.  
はんだ付けの際、水溶性フラックスはスイッチを腐食させるおそれがありますのでご使用はお避け下さい。
- Refer to following dimensions for P.C.B. mounting holes when snap-in type is used.  
(Refer to each product drawing for the dimensions of terminal holes.)  
スナップインタイプの枠を使用される場合の基板取付穴は下記寸法を参考にして下さい。(各端子の穴寸法は製品図を参考にして下さい。)

2-position type (2接点タイプ)

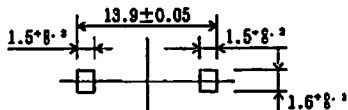

3-position type (3接点タイプ)

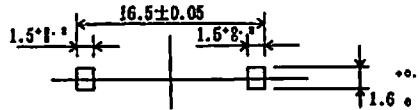

4. Caution in automatic soldering (Applied only to horizontal knob type)

Please care ingress of flux from knob portion, although protected against that from terminals.  
Please consult us when a specific knob is used, which may cause ingress of flux.

オートディップに関して (つまみ突出しタイプのみ適用)

端子部のフラックス侵入はありませんが、つまみ部は低い位置にありますので、フラックスの飛散、流入等にご注意下さい。  
つまみ形状が特殊な場合は、フラックス侵入が考えられますので、別途ご相談下さい。

6. Designing printed pattern and parts layout shall be considered because the characteristics may change due to warp of P.C.B.

基板のソリによって特性が変化する場合がありますので、パターン設計・レイアウトについては十分考慮願います。

6. When soldering, slide should be at the P position in product drawing.

はんだ付けの際、スライドのつまみを製品図と同位置に移動させてはんだ付け下さい。

7. Unstable contact may occur if the switch is used lower than DC 1V or 10mA. Please consult us for special applications.

電圧DC 1V以下または電流10mA以下で使用しますと、接触不安定となることがあります。このような用途に使用される場合は別途ご相談下さい。

8. This switch is designed and manufactured to be used for general electronic equipment such as audio-visual equipment, home electronics, information and communication related equipment. If you intend to use the switch for sophisticated equipment requiring more safety and reliability, such as life support, space and aviation, disaster prevention or security related equipment, please feel free to contact us about suitability.

本製品はオーディオ機器、映像機器、家電機器、情報機器、通信機器などの一般電子機器用に設計・製造したものです。生命維持装置、宇宙・航空機器、防災・防犯機器などの高度の安全性や信頼性が求められる用途に使用される場合は、貴社にて適合性の確認を頂くか、当社へご相談下さい。

9. In case of storing this switch for a long period (longer than six months after delivery), it must be sealed in a plastic bag and stored in a cool and dark place in order to prevent the solderability of the terminal surface from deteriorating due to film to be formed on it.

長期保管の場合(納入後6ヶ月程度以上)は、端子表面の皮膜形成によるはんだ付け性の劣化等を防ぐため、製品をビニル袋等で密封し、直射日光の当たらない暗所に保管して下さい。

背 景  
BACK GROUND  
△SI単位化

(S)

③"DETAILS (詳細)(5:1)

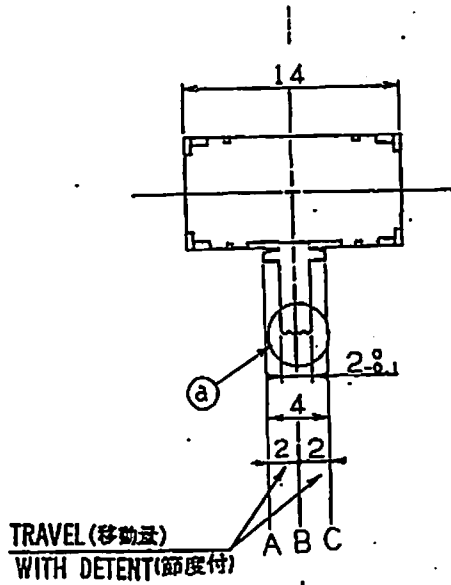
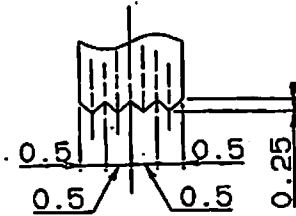

COLOR: IVORY

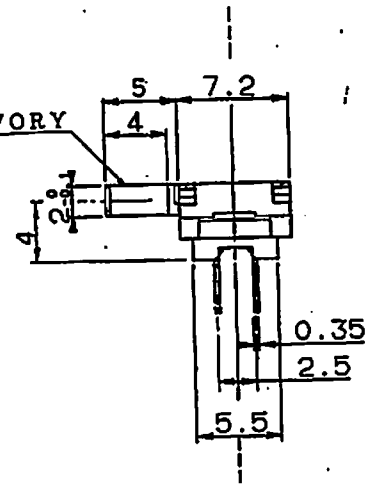

SEE DIRECTION "A"  
(A方向より見る)

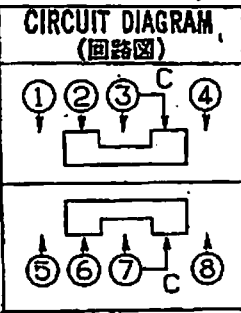

P.C. BOARD MOUNTING FACE  
(プリント基板取付面)

TERMINAL NO. ①  
(タンシ番付)

2. OPERATING FORCE. B→A, C 3±1.5N (306±153gf) (作動力)  
A, C→B 2±1N (204±102gf) (但しツマミ損元に加える.) (MEASURE AT THE BOTTOM OF KNOB)

NOTES 1. CONTACTS OF CHANGEOVER TIMING. NOT SPECIFIED (注記) (接点の切換タイミング: 規定なし)

TOLERANCES UNLESS OTHERWISE SPEC.		UNITS		SCALE		MODEL NO. (製品番号)
BASIC DIMENSIONS	TOLERANCES	mm	inch	mm	inch	SSSS928200
UP TO 4	±0.2					PRODUCT DRAWING (製品図) DOCUMENT NO.
OVER 4 UP TO 16	±0.3					
OVER 16 UP TO 63	±0.4					
OVER 63 TO 250	±0.5					
ABOVE 250	±0.7					
ANGULAR DIMENSIONS ±3°		UNITS		SCALE		

ALPS ELECTRIC CO., LTD.

APPD. Sep.-297  
CHKD. Sep.-297  
H. M.  
Yoshizawa Kise Kishi