



Type FMA



Type FMT



Type FMG

SAFETY SWITCH SENSORS type FMA / FMG / FMT

Mechan safety switches sensors are a special type of proximity switch designed for use with our range of control modules. They differ from standard proximity sensors in two important areas :

- 1) They are Fail-safe
- 2) They can only be actuated by the Mechan sensor.

Mechan safety switches are completely solid state electronic devices containing no magnets, contacts or moving parts to stick or wear out. They are resin encapsulated into an ABS case to provide a fully sealed, IP67, sensor which can withstand the most arduous of conditions, With a 10 mm switching distance they are easy to install and tolerant to mis-alignment/machine guard vibration.

There are tens of thousands of Mechan safety switches being used around the world in applications from food processing to concrete block manufacture, giving years of trouble free operation and avoiding costly down-time.

- Rugged, IP67 sensor
- 10 mm switching, tolerant to mis-alignment
- 5, 10 and 15 metre cable lengths available ex-stock, longer can be made to order
- Choice of cable protection adaptor (Ask sales if there is a particular conduit gland you require)
- Safety switch sensor cable may be extended (up to 100 metres)

TECHNICAL SPECIFICATION

SAFETY SWITCH SENSORS - TYPE FMA / FMG / FMT

PRODUCT IDENTIFICATION

- 1 Safety Sensor Oscillator (Moving Part)
- 2 Safety Sensor Receiver (Fixed Part)
- 3 Fixing Holes (2 x 6 mm diameter)
- 4 Cable protection / conduit gland
- 5 Cable encapsulated into sensor

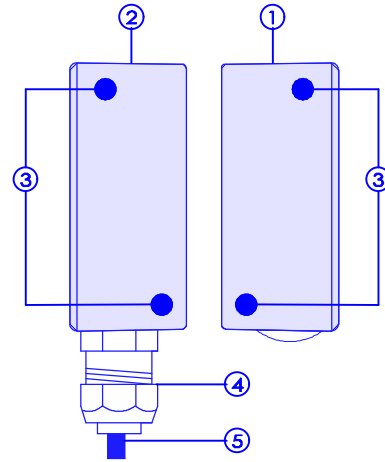

SPECIFICATION

Part Numbers	FMA / FMG / FMT (+ cable length i.e. 5m / 10m)
Construction	ABS Case; Resin filled
IP Rating	IP67
Fixing	6 mm diameter holes
Cable Type	Single Twisted pair, Foil Shield & Drain
Cable Lengths Available	5, 10 & 15 metres (longer available to order)
Cable Protection Adaptors	
Part Number -FMA	16 mm liquid tight flexible conduit adaptor
FMG	Nylon Cord Grip, 4 to 11 mm
FMT	20 mm Brass Male Thread

(The above cable adaptors are available from stock, specials can be made to order)

DIMENSIONS

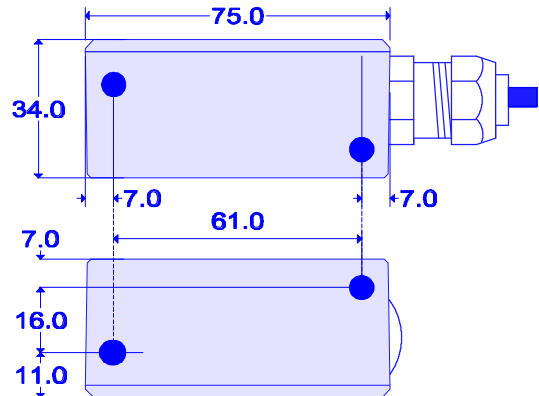

The dimension through the fixing holes is 32 mm

ADDITIONAL ORDERING INFORMATION

- 1 Part Numbers : For the FMA with 5 metres of cable the part number = FMA-5M
- 2 The cable can be extended using a similar type of cable (Belden 8761 or equivalent) Maximum length 100 mtrs.

See the 'F' Series Safety System literature, document number: **f-lit-v2** for more general information or the 'F' Series Installation Guide for detailed installation notes, document number **f-ins-v2**



The 'F' series Mechan Safety switch complies with all relevant Essential Health and Safety Requirements of the Machinery Directive (89/392/EEC & amendments 91/368/EEC, 94/44/EEC). The 'F' series has been independently tested to meet the 'Heavy Industrial' Specification of the EMC Directive for both emissions and immunity (BS EN 50081-2 & 50082-2) The CE marking relates to the EMC Directive.

Copies of the Certificate of Conformity can be obtained from Mechan Controls Limited

In the interest of product development, specifications are subject to change without notice.
Document No. - f-fma-V3 / 1/10/98

It is the responsibility of the user to ensure compliance with any acts or by-laws in force.

All information regarding Mechan equipment is believed to be accurate at the time of printing. Responsibility cannot be accepted for errors or omissions.