



Electrical Characteristics

Absolute Maximum Ratings

Parameter	Min.	Max.	Unit
Storage Temperature	-40	+150	°C
Supply Voltage(VDD)	2.7	3.6	DCV
Supply Voltage(P ₁ VCC)	3.0	3.3	DCV
Other Pin Voltage	V _{ss} -0.4	VDD+ 0.4	DCV

Recommended Operating Conditions

Parameter	Min.	Max.	Unit
Temperature	-20	+75	°C
Supply Voltage for UART	3.0	3.6	DCV
Supply Voltage for USB	3.0	3.6	DCV

General Electrical Specification

Parameter	Description	Min.	Typ.	Max.	Unit
Carrier Frequency		2.402		2.480	GHz
RF Output Power	Measured in 50ohm	15	16.5	18	dBm
RX sensitivity		-	-88	-86	dBm
Load Impedance	No abnormal Oscillation			5:1	
Input Low Voltage	RESET,UART,G PIO ,PCM	-0.30	-	0.80	DCV
Input High Voltage	RESET,UART,G PIO ,PCM	0.7VDD	-	VDD+ 0.3	DCV
Output Low Voltage	UART,G PIO ,PCM	-	-	0.40	DCV
Output High Voltage	UART,G PIO ,PCM	VDD -0.4	-	-	DCV
Average Current Consumption	Receive DM1		114		mA

Radio Characteristics - Basic Data Rate

Transmitter , VDD = 3.3V Temperature = + 20°C

	Frequency (GHz)	Min.	Typ.	Max.	Bluetooth Specification	Unit
RF transmit power	2.402	15	16.5	18	-6 to +20	dBm
	2.441	15	16.5	18		dBm
	2.480	15	16.5	18		dBm
Initial carrier frequency tolerance	2.402	-	12	25	± 75	kHz
	2.441	-	10	25		kHz
	2.480	-	9	25		kHz
-20dB bandwidth for modulated carrier	2.402	-	890	1000	≤ 1000	kHz
	2.441	-	870	1000		kHz
	2.480	-	820	1000		kHz
Carrier Frequency Drift (single slot packet DH1)	2.402	-	±10	±20	≤25	kHz
	2.441	-	±10	±20		kHz
	2.480	-	±10	±20		kHz
Carrier Frequency Drift (five slot packet DH5)	2.402	-	±10	±20	≤40	kHz
	2.441	-	±10	±20		kHz
	2.480	-	±10	±20		kHz
Drift Rate	2.402	-	±7	±14	≤20	kHz/50µs
	2.441	-	±7	±14		kHz/50µs
	2.480	-	±7	±14		kHz/50µs
RF power control range		16	25	-	≥16	dB



Ɖ f1 ^{avg} "Maximum Modulation "	2.402	145	165	170	140 < Ɖ f1 ^{avg} < 175	kHz
	2.441	145	165	170		kHz
	2.480	145	165	170		kHz
Ɖ f2 ^{maz} "Minimum Modulation "	2.402	115	150	-	>115	kHz
	2.441	115	150	-		kHz
	2.480	115	150	-		kHz
Adjacent channel transmit power F =F ₀ ±2MHz		-	-35	-20	≤ - 20	dB m
Adjacent channel transmit power F =F ₀ ±3MHz		-	-45	-40	≤ - 40	dB m
Adjacent channel transmit power F >F ₀ +3MHz		-	-50	-40	≤ - 40	dB m
Adjacent channel transmit power F <F ₀ -3MHz		-	-50	-40	≤ - 40	dB m

Receiver, VDD =3.3V Temperature = + 20°C

	Fre quency (G Hz)	Min.	Typ .	Max.	Bluetooth Specification	U nit
Sensitivity at 0.1% BER (S ingle slot packets)	2.402	-	-88	-86	≤ - 70	dBm
	2.441	-	-88	-86		dBm
	2.480	-	-88	-86		dBm
Sensitivity at 0.1% BER (Multi slot packets)	2.402	-	-88	-86	≤ - 70	dBm
	2.441	-	-88	-86		dBm
	2.480	-	-88	-86		dBm
Maximum received signal level at 0.1% BER	2.402	-20	-10	-	≥ - 20	dBm
	2.441	-20	-10	-		dBm
	2.480	-20	-10	-		dBm
C/I co-channel		-	6	11	≤ 11	dB
Adjacent channel selectivity C/I F= F ₀ + 1 MHz		-	-4	-	≤ 0	dB
Adjacent channel selectivity C/I F= F ₀ - 1MHz		-	-4	-	≤ 0	dB
Adjacent channel selectivity C/I F= F ₀ + 2 MHz		-	-38	-	≤ - 30	dB
Adjacent channel selectivity C/I F= F ₀ - 2MHz		-	-23	-	≤ - 20	dB
Adjacent channel selectivity C/I F > F ₀ + 3 MHz		-	-45	-	≤ - 40	dB
Adjacent channel selectivity C/I F < F ₀ -5 MHz		-	-44	-	≤ - 40	dB
Adjacent channel selectivity C/I F =F _{image}		-	-22	-	≤ - 9	dB
F ₀ = 2441 MHz						
Maximum level of intermodulation interference (n= 5)			-30		≥ -39	dBm

Radio Characteristics – Enhance d Data Rate

Transmitter, VDD =3.3V Temperature = + 20°C

	Fre quency (G Hz)	Min.	Typ .	Max.	Bluetooth Specification	Unit
Maximum RF transmit power ^(note)	2.402	-	6	-	-6 to +20	dBm
	2.441	-	6	-		dBm
	2.480	-	7	-		dBm
Relative transmit power		-	-1.6	-	-4 to +1	dB
? /4 DQ PSK Maximum carrier frequency stability w _o		-	2	-	≤ ±10 for all blocks	kHz
? /4 DQ PSK Maximum carrier frequency stability w _i		-	6	-	≤ ±75 for all packets	kHz
? /4 DQ PSK Maximum carrier frequency stability w _o + w _i		-	8	-	≤ ±75 for all blocks	kHz
8 DPSK Maximum carrier frequency stability w _o		-	2	-	≤ ±10 for all blocks	kHz



8 DPSK Maximum carrier frequency stability w_i	-	6	-	$\leq \pm 75$ for all packets	kHz	
8 DPSK Maximum carrier frequency stability $ w_o + w_i $	-	8	-	$\leq \pm 75$ for all blocks	kHz	
? /4 DQ PSK Modulation Accuracy	RMS DVEM	-	7	-	≤ 20	%
	99% DEVM	-	13	-	≤ 30	%
	Peak DEVM	-	19	-	≤ 35	%
8 DPSK Modulation Accuracy	RMS DVEM	-	7	-	≤ 13	%
	99% DEVM	-	13	-	≤ 20	%
	Peak DEVM	-	17	-	≤ 25	%
In-band spurious emissions	$F > F_0 + 3$ MHz	-	< -50	-	≤ -40	dBm
	$F < F_0 - 3$ MHz	-	< -50	-	≤ -40	dBm
	$F = F_0 - 3$ MHz	-	-46	-	≤ -40	dBm
	$F = F_0 - 2$ MHz	-	-34	-	≤ -20	dBm
	$F = F_0 - 1$ MHz	-	-35	-	≤ -26	dBm
	$F = F_0 + 1$ MHz	-	-35	-	≤ -26	dBm
	$F = F_0 + 2$ MHz	-	-31	-	≤ -20	dBm
$F = F_0 + 3$ MHz	-	-33	-	≤ -40	dBm	
EDR Differential Phase Enc oding		No Errors		≥ 99	%	

Receiver, VDD =3.3V Temperature = + 20°C

	Modulation	Min.	Typ .	Max.	Bluetooth Specification	Unit
Sensitivity at 0.1% BER	? /4 DQ PSK	-	-87	-	≤ -70	dBm
	8 DPSK	-	-78	-	≤ -70	dBm
Maximum received signal level at 0.1% BER	? /4 DQ PSK	-	-8	-	≥ -20	dBm
	8 DPSK	-	-10	-	≥ -20	dBm
C/I co-channel at 0.1% BER	? /4 DQ PSK	-	10	-	$\leq + 13$	dB
	8 DPSK	-	19	-	$\leq + 21$	dB
Adjacent channel selectivity C/I $F = F_0 + 1$ MHz	? /4 DQ PSK	-	-10	-	≤ 0	dB
	8 DPSK	-	-5	-	$\leq + 5$	dB
Adjacent channel selectivity C/I $F = F_0 - 1$ MHz	? /4 DQ PSK	-	-11	-	≤ 0	dB
	8 DPSK	-	-5	-	$\leq + 5$	dB
Adjacent channel selectivity C/I $F = F_0 + 2$ MHz	? /4 DQ PSK	-	-40	-	≤ -30	dB
	8 DPSK	-	-40	-	≤ -25	dB
Adjacent channel selectivity C/I $F = F_0 - 2$ MHz	? /4 DQ PSK	-	-23	-	≤ -20	dB
	8 DPSK	-	-20	-	≤ -13	dB
Adjacent channel selectivity C/I $F = F_0 + 3$ MHz	? /4 DQ PSK	-	-45	-	≤ -40	dB
	8 DPSK	-	-45	-	≤ -33	dB
Adjacent channel selectivity C/I $F = F_0 - 5$ MHz	? /4 DQ PSK	-	-45	-	≤ -40	dB
	8 DPSK	-	-45	-	≤ -33	dB
$F_0 = 2405, 2441, 2477$ MHz						
Adjacent channel selectivity C /I $F = F_{image}$? /4 DQ PSK		-20		≤ -7	dB
	8 DPSK		-15		≤ 0	dB

Note :

Measurement made using a POWER_TABLE entry of TX_PRE 80, INT PA63, EXT PA255. This ensures that the Bluetooth requirements for ACP and those defined by the FCC and ETSI are satisfied over the operating temperature range of -5D to $+ 45\text{D}$. Although the design is capable of generating in excess of $+ 18$ dBm, regulatory compliance over the full temperature range of -5D to $+ 45\text{D}$ will not be satisfied if the transmit power approaches this value.



Pin No.	Pin Name	Pin Type	Description
1	GND	GND	Common ground
2	PVCC	Power	Power Amp. Power Supply(3.3V)
3	AIO (0)	Bi-directional	Programmable I/O terminal , 32KHz sleep clock input
4	AIO (1)	Bi-directional	Programmable I/O terminal
5	PIO (0)	Bi-directional	Programmable I/O terminal , RX Enable
6	PIO (1)	Bi-directional	Programmable I/O terminal , TX Enable
7	PIO (2)	Bi-directional	Programmable I/O terminal , USB_PULL_UP , CLK_REQ_OUT
8	PIO (3)	Bi-directional	Programmable I/O terminal , USB_WAK E_UP , CLK_REQ_IN
9	PIO (4)	Bi-directional	Programmable I/O terminal , USB_ON , BT_Priority/Ch_Clk output for co-existence signalling
10	GND	GND	Common ground
11	PIO (5)	Bi-directional	Programmable I/O terminal , USB_DETACH , BT_Active output for co-existence signalling
12	PIO (6)	Bi-directional	Programmable I/O terminal , CLK_REQ , WLAN_Active/Ch_Data input for for co-existence signalling
13	PIO (7)	Bi-directional	Programmable I/O terminal
14	PIO (8)	Bi-directional	Programmable I/O terminal
15	PIO (9)	Bi-directional	Programmable I/O terminal
16	RESET	CMOS input	Reset input of module, Active low reset
17	VCC	Power	Module power supply input
18	GND	GND	Common ground
19	GND	GND	Common ground
20	USB_DP	Bi-directional	USB data plus
21	USB_DN	Bi-directional	USB data minus
22	PCM_SYNC	Bi-directional	Synchronous data sync
23	PCM_IN	CMOS input	Synchronous data input
24	PCM_OUT	CMOS output	Synchronous data output
25	PCM_CLK	Bi-directional	Synchronous data clock
26	UART_RX	CMOS input	UART data input
27	UART_TX	CMOS output	UART data output
28	UART_RTS	CMOS output	UART request to send(active low)
29	GND	GND	Common ground
30	UART_CTS	CMOS input	UART clear to send(active low)
31	SPI_MOSI	CMOS input	Serial Peripheral Interface data input
32	SPI_CSB	CMOS input	Chip select for Synchronous Serial Interface(active low)
33	SPI_CLK	CMOS input	Serial Peripheral Interface clock
34	SPI_MISO	CMOS output	Serial Peripheral Interface data output
35	PIO (11)	Bi-directional	Programmable I/O terminal
36	PIO (10)	Bi-directional	Programmable I/O terminal
37	RF_IO	Analogue	Antenna interface
38	GND	GND	Common ground



Dimension

Unit : mm

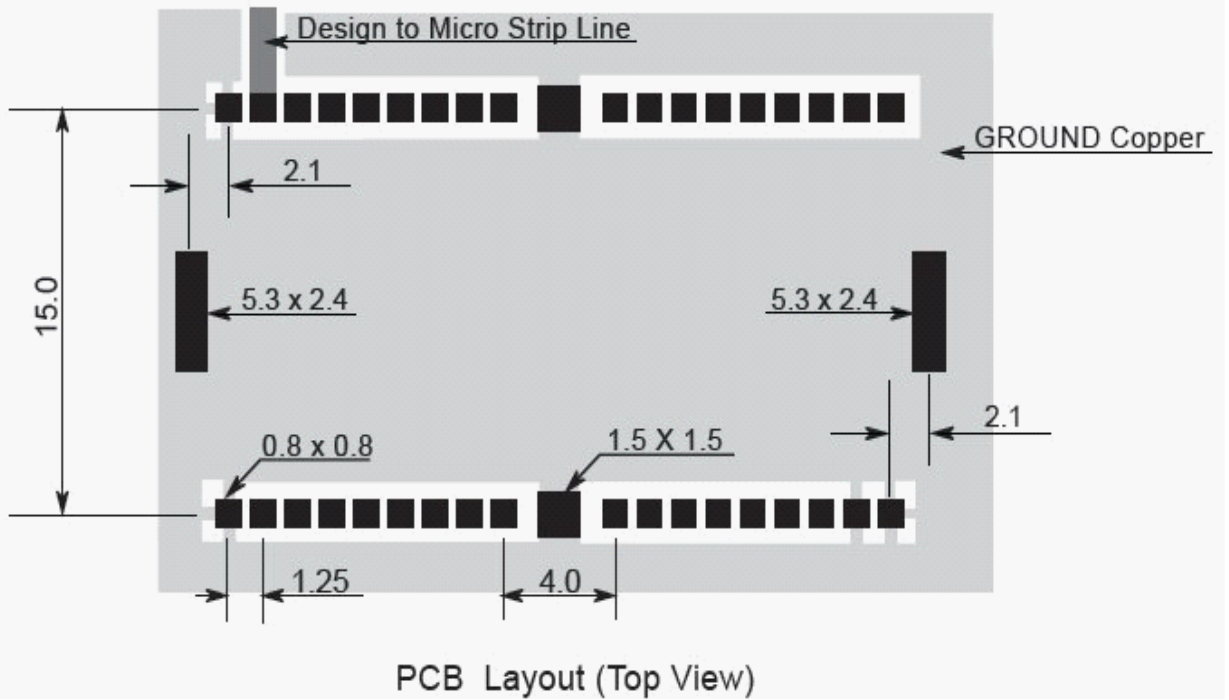
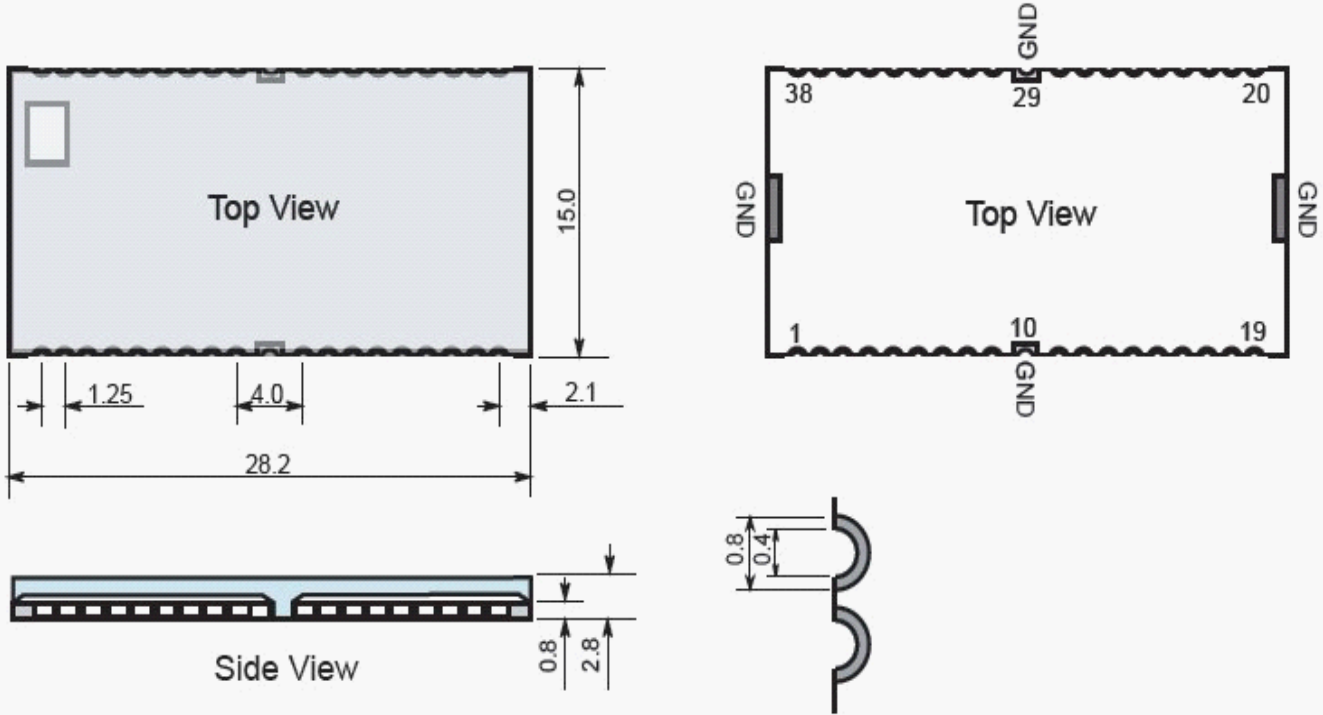



Bluetooth Module - Part Code LM-400

Class 1 BC04

Features

- ⊕ Bluetooth Ver. 2.0+ EDR certification
- ⊕ Transmit Power up to +18dBm(class1)
- ⊕ Low current consumption:
Hold, Sniff, Park, Deep sleep mode
- ⊕ 3.0V to 3.6V operation
- ⊕ Full Bluetooth Data rate over UART and USB
- ⊕ Support up to 7 ACL links and 3 SCO links
- ⊕ Enhanced Data Rate(EDR) compliant for both 2Mbps and 3Mbps modulation modes
- ⊕ Interface: USB, UART&PCM(for voice codec)
- ⊕ SPP,HSP/HFP,HID,DUN firmware are available
- ⊕ Support for 802.11 Co Existence
- ⊕ RoHS Compliant
- ⊕ Small outline: 28.2 X 15.0 X 2.8 mm

Application

- ⊕ Access point
- ⊕ Domestic and Industrial applications
- ⊕ Personal Digital Assistants(PDA)
- ⊕ Serial Adapter
- ⊕ GPS, POS, Barcode Reader
- ⊕ Digital camera, Printer & Cellular phone
- ⊕ Cordless handset

