

Infrared Light Emitting Diode

OP270 Series



Features:

- High power GaAIAs
- 1.9 mm water clear plastic SMD package
- 890 nm wavelength
- Narrow beam angle
- Choice of four lead configurations

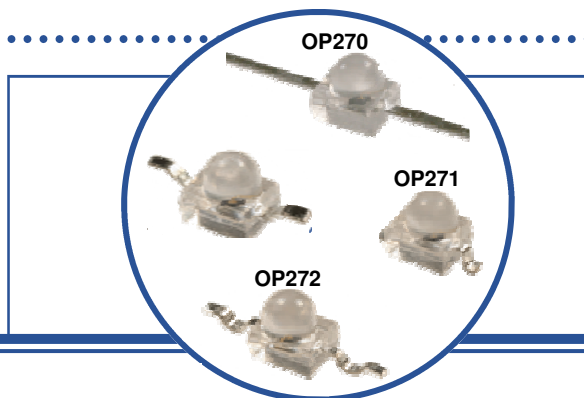

Description:

Each device in this series is a GaAIAs infrared LED mounted in a clear plastic SMD package. Each device has an integral molded lens that enables a narrow beam angle and provides an even emission pattern. This series offers four lead configurations, which are compatible with most automated mounting equipment. *OP270 Series LEDs are mechanically and spectrally matched to OP570 series phototransistors.*

Please refer to Application Bulletins 208 and 210 for additional design information and reliability (degradation) data.

Applications:

- Non-contact position sensing
- Datum detection
- Machine automation
- Optical encoding
- IrDA
- Reflective and transmissive sensing

Ordering Information			
Part Number	LED Peak Wavelength	Total Beam Angle	Lead Configuration
OP270	890 nm	25°	Axial
OP271			Gull Wing
OP272			Yoke
OP273			Rev. Gull

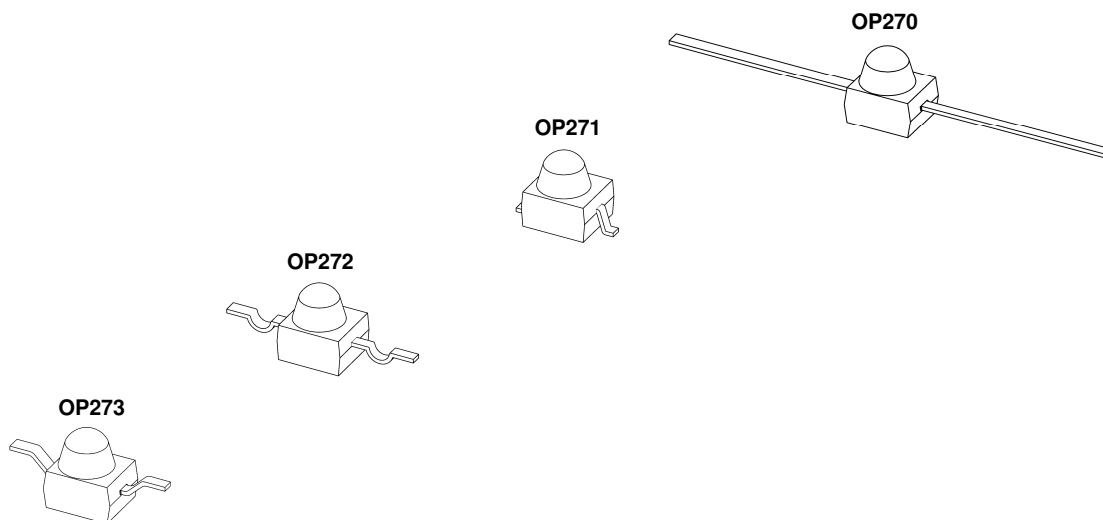

RoHS

OPTEK reserves the right to make changes at any time in order to improve design and to supply the best product possible.

Infrared Light Emitting Diode

OP270 Series

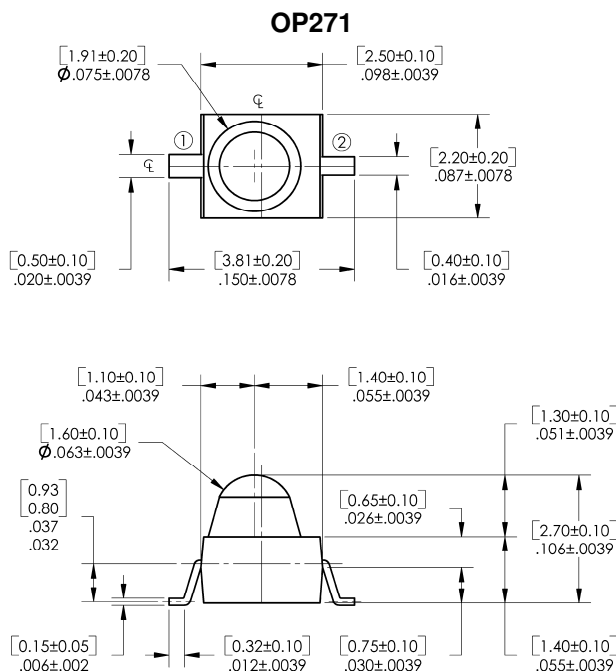
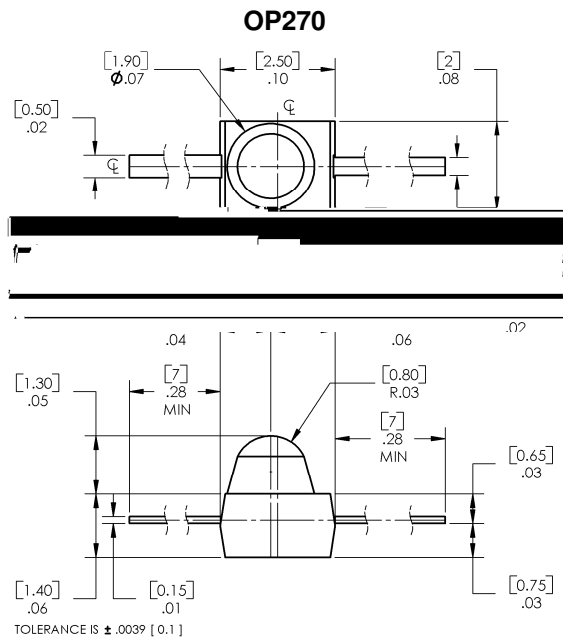

DIMENSIONS ARE IN: [MILLIMETERS] INCHES

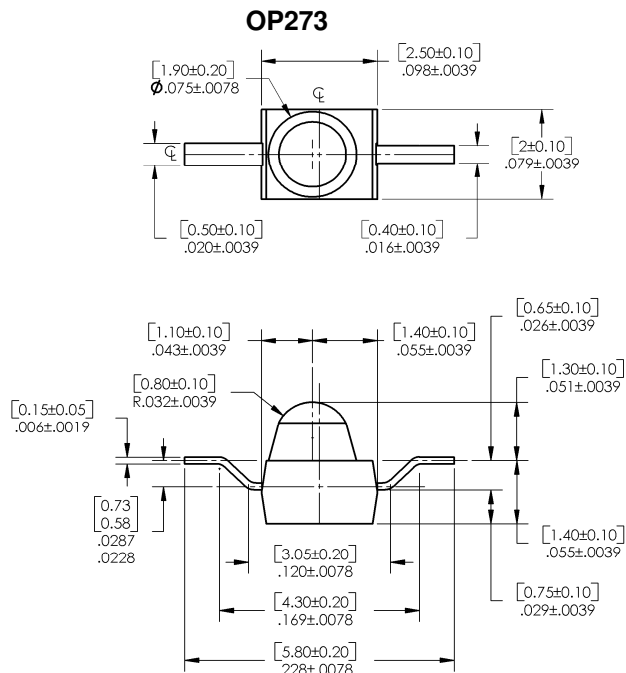
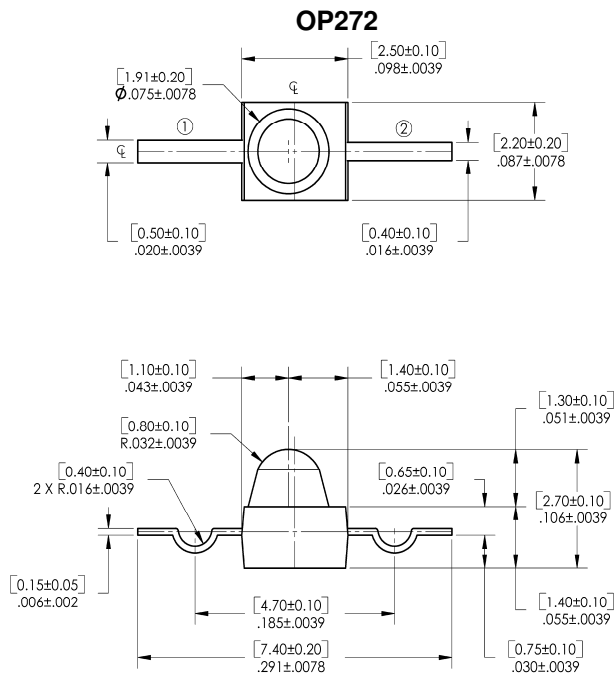

Pin #	LED
1	Anode
2	Cathode

OPTEK reserves the right to make changes at any time in order to improve design and to supply the best product possible.

0 n
ADDITION

...make changes at any time in order to ... design and to supply the best product possible.

Forward Current vs. Ambient Temperature

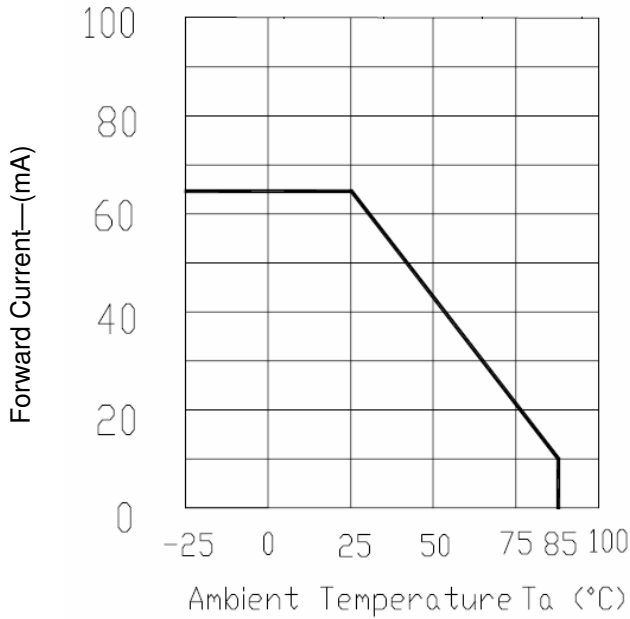

Spectral Distribution

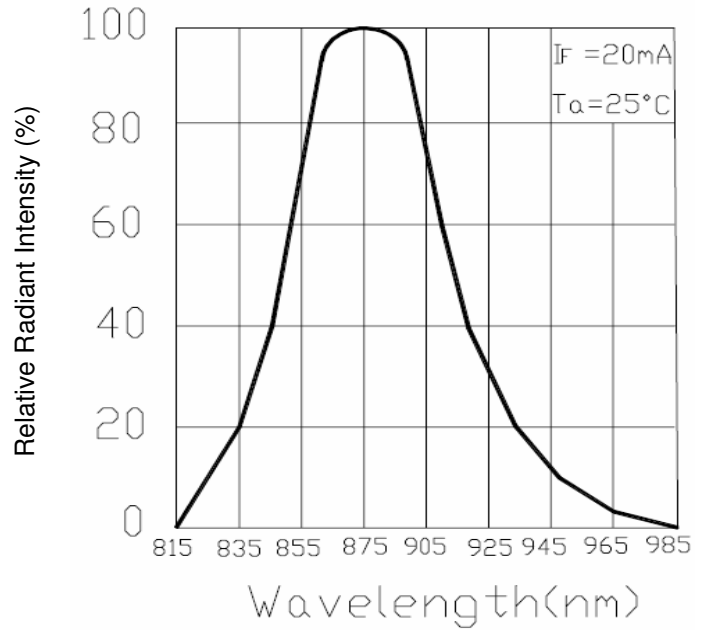

Peak Emission Wavelength vs. Ambient Temperature

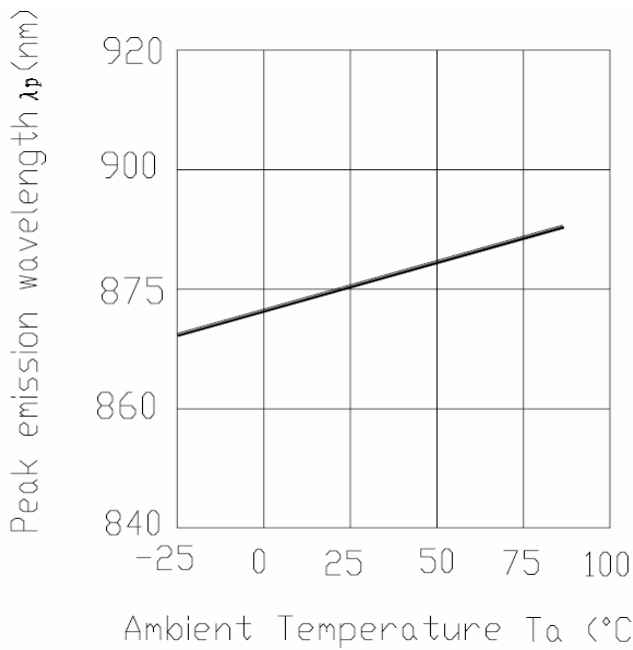

Forward Current vs. Forward Voltage

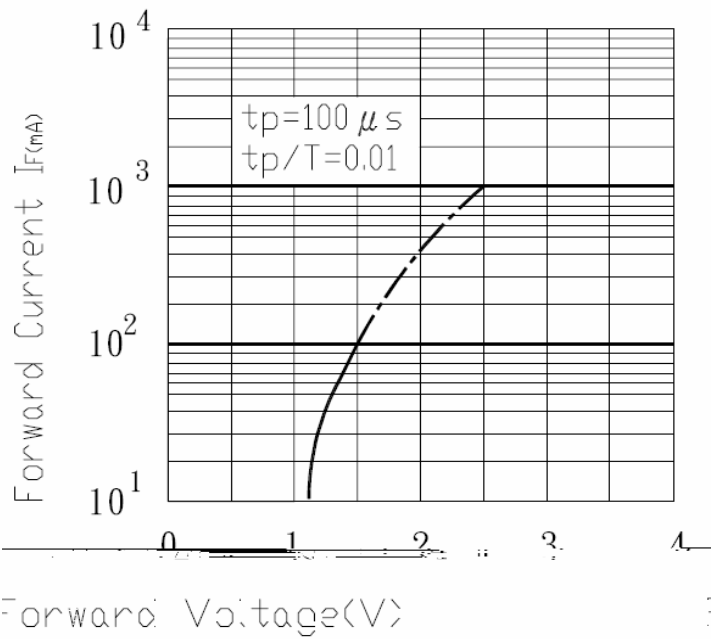

OPTEK reserves the right to make changes at any time in order to improve design and to supply the best product possible.

**Relative Radiant intensity
Vs. Angular Displacement**

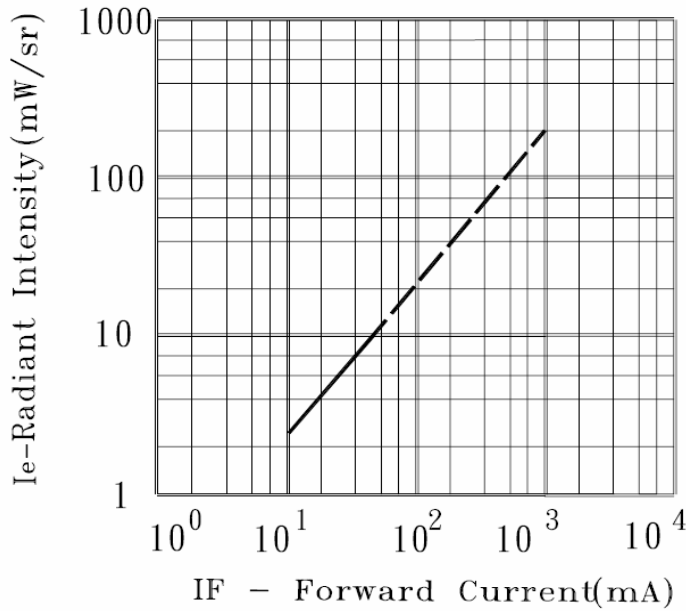

**Relative Radiant intensity
Vs. Angular Displacement**

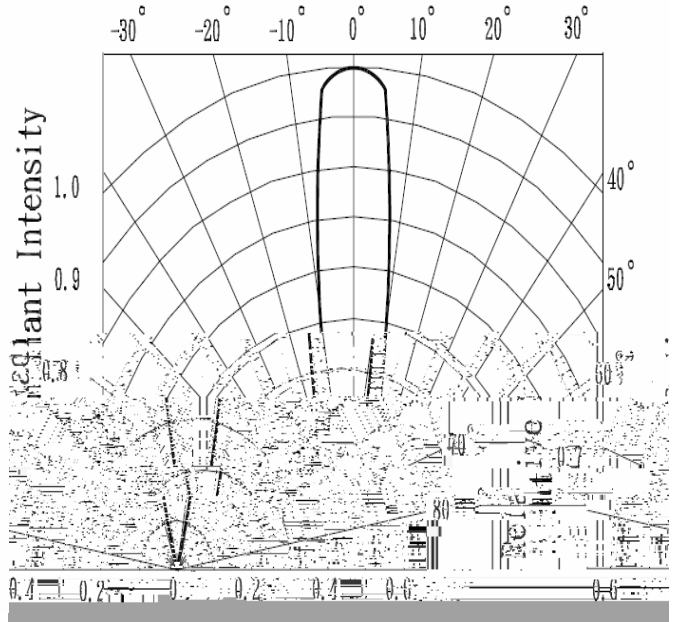

**Relative Intensity vs.
Ambient Temperature**

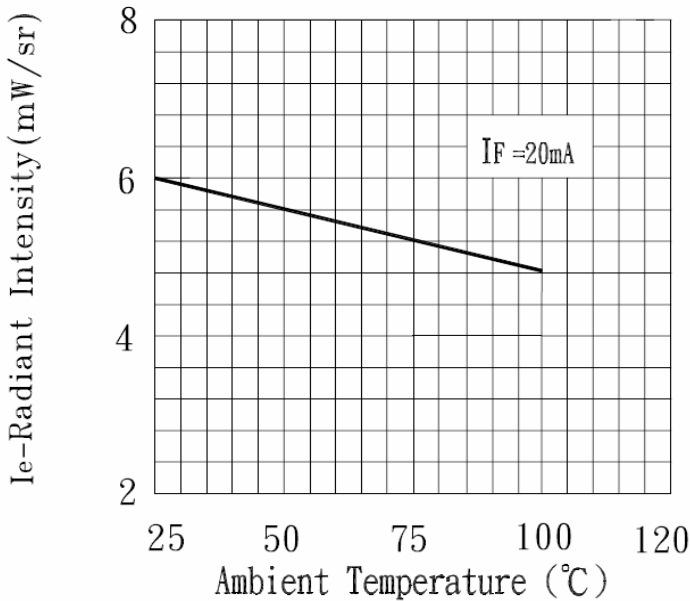

**Relative Intensity vs.
Ambient Temperature**

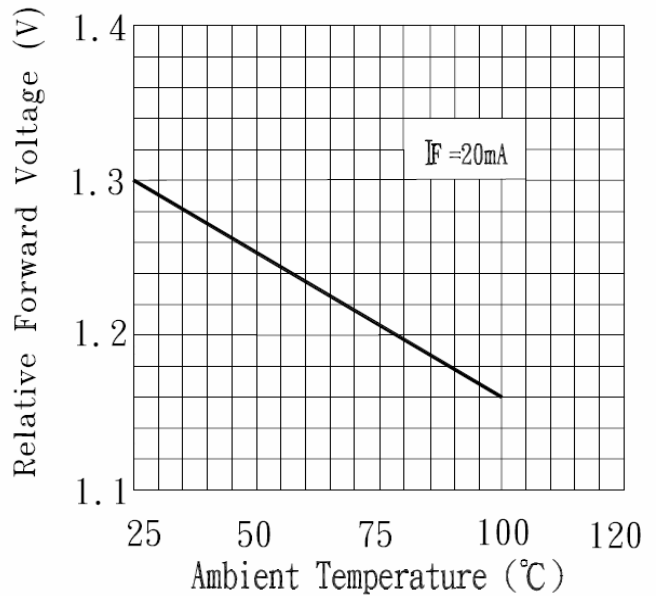

OPTEK reserves the right to make changes at any time in order to improve design and to supply the best product possible.